

CK1,0-ED-1,0ST AU - Crimp contact



1409082

<https://www.phoenixcontact.com/us/products/1409082>

Please be informed that the data shown in this PDF document is generated from our online catalog. Please find the complete data in the user documentation. Our general terms of use for downloads are valid.



Crimp contact, series: VARIOCON, Pin, turned, contact diameter: 1 mm, connection cross section: 0.14 mm² ... 1 mm², AWG 26...18, contact material: Cu, this item is expected to be lead-free from Q2 2026 in accordance with RoHS II without exception 6c (Pb < 0.1%), a lead-free alternative is possible on request in advance

Commercial data

Item number	1409082
Packing unit	100 pc
Minimum order quantity	100 pc
Sales key	AB01
Product key	ABLADE
GTIN	4046356619400
Weight per piece (including packing)	0.342 g
Weight per piece (excluding packing)	0.32 g
Customs tariff number	85366990
Country of origin	DE

Technical data

Notes

Safety note

Safety note

WARNING: The connectors may not be plugged in or disconnected under load. Ignoring the warning or improper use may damage persons and/or property.

- WARNING: Commission properly functioning products only. The products must be regularly inspected for damage. Decommission defective products immediately. Replace damaged products. Repairs are not possible.

- WARNING: Only electrically qualified personnel may install and operate the product. They must observe the following safety notes. The qualified personnel must be familiar with the basics of electrical engineering. They must be able to recognize and prevent danger. The relevant symbol on the packaging indicates that only personnel familiar with electrical engineering are allowed to install and operate the product.

- The products are suitable for applications in plant, controller, and electrical device engineering.

- When operating the connectors in outdoor applications, they must be separately protected against environmental influences.

- Assembled products may not be manipulated or improperly opened.

- Only use mating connectors that are specified in the technical data of the standards listed (e.g. the ones listed in the product accessories online at [phoenixcontact.com/products](https://www.phoenixcontact.com/products)).

- When using the product in direct connection with third-party manufacturers, the user is responsible.

- For operating voltages > 50 V AC, conductive connector housings must be grounded

- Ensure that the protective or functional ground has been properly connected.

- VDE 0100/1.97 § 411.1.3.2 and DIN EN 60 204/11.98 § 14.1.3 are applicable when combining several circuits in a cable and/or connector

- Observe the corresponding technical data. You will find information:

- o On the product

- o On the packing label

- o In the supplied documentation

- o Online at [phoenixcontact.com/products](https://www.phoenixcontact.com/products) under the product

- Only use tools recommended by Phoenix Contact

- The installation notes/Design In documents online on the download page at [phoenixcontact.com/products](https://www.phoenixcontact.com/products) must be observed for this product.

- Use a protective cap to protect connectors that are not in use. The suitable accessories are available online in the accessory section of the product at [phoenixcontact.com/products](https://www.phoenixcontact.com/products)

- Operate the connector only when it is fully plugged in.

- Ensure that when laying the cable, the tensile load on the connectors does not exceed the upper limit specified in the

CK1,0-ED-1,0ST AU - Crimp contact



1409082

<https://www.phoenixcontact.com/us/products/1409082>

standards.

- Observe the minimum bending radius of the cable. Lay the cable without twisting it.
- The connector warms up in normal operation. Depending on the ambient conditions, the surface of the connector can continue to warm up. In this case, the user is responsible for posting warnings (e.g. DIN EN ISO 13732-1:2008-12).

Product properties

Product type	Crimp contact
Series	VARIOCON
Contact material type	turned

Connection data

Connection technology

Contact connection type	Pin
Connection method	Crimp connection

Conductor connection

Stripping length	4.5 mm
Connection cross section	0.14 mm ² ... 1 mm ²
Connection cross section AWG	26 ... 18

Material specifications

Material Contact	Cu
Material Contact surface	Au

Dimensions

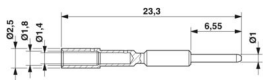
Dimensional drawing	
Width [w]	2.5 mm
Height [h]	2.5 mm
Length [l]	20.8 mm
Diameter (Contact diameter)	1 mm

Mechanical properties

Mechanical data

Insertion/withdrawal cycles	≥ 100
-----------------------------	-------

Environmental and real-life conditions

Ambient conditions

Ambient temperature (operation)	-40 °C ... 125 °C
---------------------------------	-------------------

CK1,0-ED-1,0ST AU - Crimp contact



1409082

<https://www.phoenixcontact.com/us/products/1409082>

Drawings

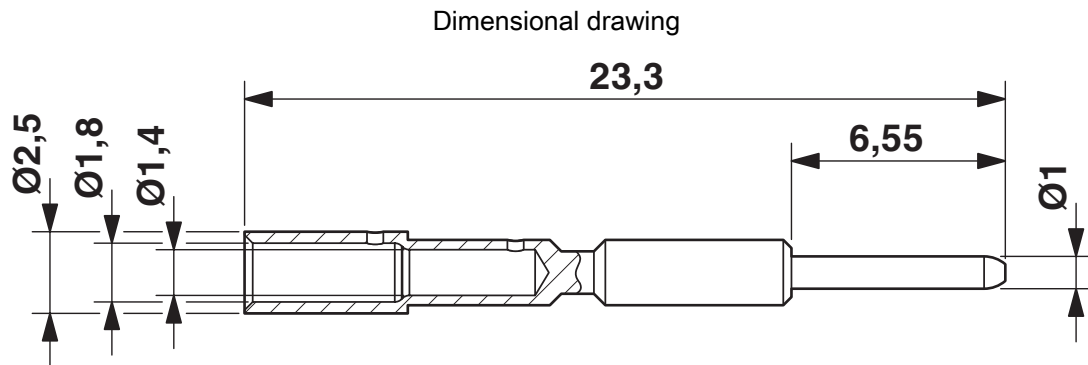

Dimensional drawing

CK1,0-ED-1,0ST AU - Crimp contact



1409082

<https://www.phoenixcontact.com/us/products/1409082>

Classifications

ECLASS

ECLASS-13.0	27440204
ECLASS-15.0	27440204

ETIM

ETIM 10.0	EC000796
-----------	----------

UNSPSC

UNSPSC 21.0	39121500
-------------	----------

CK1,0-ED-1,0ST AU - Crimp contact



1409082

<https://www.phoenixcontact.com/us/products/1409082>

Environmental product compliance

EU RoHS

Fulfills EU RoHS substance requirements	Yes
Exemption	6(c)

China RoHS

Environment friendly use period (EFUP)	EFUP-50
	An article-related China RoHS declaration table can be found in the download area for the respective article under "Manufacturer declaration". For all articles with EFUP-E, no China RoHS declaration table issued and required.

EU REACH SVHC

REACH candidate substance (CAS No.)	Lead(CAS: 7439-92-1)
SCIP	c52eff35-d7fa-4dbd-94f6-b2d1e8049f4b

Phoenix Contact 2026 © - all rights reserved

<https://www.phoenixcontact.com>

Phoenix Contact USA
586 Fulling Mill Road
Middletown, PA 17057, United States
(+717) 944-1300
info@phoenixcon.com