

QPD 5P/ 1,0-PVC/5P 5X2,5 BK - Connecting cable



1408720

<https://www.phoenixcontact.com/us/products/1408720>

Please be informed that the data shown in this PDF document is generated from our online catalog. Please find the complete data in the user documentation. Our general terms of use for downloads are valid.

Preassembled QUICKON connectors, 4+PE, black, with 5x 2.5 PVC cable, length: 1.0 m



Your advantages

- Innovative and time saving - QUICKON fast connection for time saving of up to 80 % for on-site connection
- Robust throughout: housing with IP68/IP69K and IK07 protection for a wide range of applications
- Safer connection with mechanical coding to protect against mismatching, and touch-proof protection in accordance with DIN EN 0105
- Easy maintenance – the connectors enable fast device replacement and preassembled cables simplify startup

Commercial data

Item number	1408720
Packing unit	1 pc
Minimum order quantity	1 pc
Sales key	BF50
Product key	AF6GCX
GTIN	4046356827188
Weight per piece (including packing)	398.9 g
Weight per piece (excluding packing)	398.9 g
Customs tariff number	85444290
Country of origin	PL

QPD 5P/ 1,0-PVC/5P 5X2,5 BK - Connecting cable



1408720

<https://www.phoenixcontact.com/us/products/1408720>

Technical data

Product properties

Product type	Assembled installation cable
Product family	QPD
Type	QPD 5x2,5
Number of positions	5
Connection profile	4+PE
Position marking	1, 2, 3, N, PE
Number of connections	5
Number of connections per position	1

Insulation characteristics

Overvoltage category	III
Degree of pollution	3

Electrical properties

Rated surge voltage (II/2)	8 kV
Rated surge voltage (III/2)	8 kV
Rated surge voltage (III/3)	6 kV
Rated current	20 A
Contact resistance	< 4 mΩ
rated voltage (II/2)	1000 V
rated voltage (III/2)	1000 V
Rated voltage (III/3)	690 V
Nominal voltage U_N	690 V AC 690 V DC
Nominal current I_N	20 A

Connection data

Connection technology

Connection method On the field side	IDC connection
Frequency of connections between conductors of the same cross section	max. 10

Conductor connection

Conductor cross-section flexibel	1 mm ² ... 2.5 mm ²
Conductor cross-section solid	1 mm ² ... 2.5 mm ²
Connection cross section AWG	16 ... 14
Tightening torque Union nut	10 Nm
Wrench size Union nut	27 mm

Dimensions

QPD 5P/ 1,0-PVC/5P 5X2,5 BK - Connecting cable



1408720

<https://www.phoenixcontact.com/us/products/1408720>

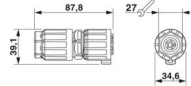
Dimensional drawing	
Width	34.6 mm
Height	39.1 mm
Length	1.18 m
Diameter	34.6 mm

Material specifications

Color	black (RAL 9005)
Material Housing	PA
Material Contact	Cu
Material Contact surface	silver-plated
Flammability rating according to UL 94	V0
Material wire insulation	PVC/PE/TPE/rubber

Cable/line

Cable length	1 m
--------------	-----

PVC gray [PVC]

Shielded	no
Cable weight	242 kg/km
Cable type	PVC gray
Cable type (abbreviation)	PVC
External cable diameter	11.80 mm
Outer sheath, material	PVC
External sheath, color	gray RAL 7001
Conductor material	Bare Cu litz wires
Conductor structure, voltage supply	50x 0.25 mm
Conductor cross-section	5x 2.5 mm ²
AWG power supply	14
Material wire insulation	PVC
Single wire, color	blue, brown, black, gray, green/yellow
Overall twist	5 cores, twisted
Nominal voltage, cable	750 V 1000 V (Fixed, protected installation)
Test voltage, cable	4000 V
Cable insulation resistance	> 0.2 MΩ*km
Minimum bending radius, fixed installation	4 x D
Minimum bending radius, flexible installation	15 x D
Flame resistance	according to IEC 60332-1-2
Ambient temperature (operation)	-5 °C ... 70 °C (Cable, flexible installation) -40 °C ... 80 °C (cable, fixed installation)

QPD 5P/ 1,0-PVC/5P 5X2,5 BK - Connecting cable



1408720

<https://www.phoenixcontact.com/us/products/1408720>

Mechanical properties

Mechanical data

Insertion/withdrawal cycles	max. 50
-----------------------------	---------

Environmental and real-life conditions

Ambient conditions

Degree of protection	IP66
	IP68 (2 m / 24 h)
	IP69K
Impact strength	IK07
Ambient temperature (operation)	-40 °C ... 100 °C
Temperature when conductor connected	-5 °C ... 50 °C
Ambient temperature (storage/transport)	-40 °C ... 80 °C

QPD 5P/ 1,0-PVC/5P 5X2,5 BK - Connecting cable

1408720

<https://www.phoenixcontact.com/us/products/1408720>



Drawings

Dimensional drawing

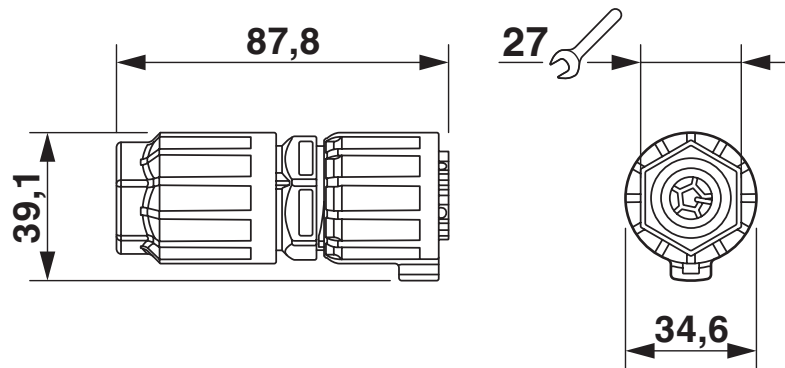

Dimensional drawing: connector, 2.5 mm²

QPD 5P/ 1,0-PVC/5P 5X2,5 BK - Connecting cable



1408720

<https://www.phoenixcontact.com/us/products/1408720>

Classifications

ECLASS

ECLASS-13.0	27440604
ECLASS-15.0	27440604

UNSPSC

UNSPSC 21.0	39121402
-------------	----------

QPD 5P/ 1,0-PVC/5P 5X2,5 BK - Connecting cable



1408720

<https://www.phoenixcontact.com/us/products/1408720>

Environmental product compliance

EU RoHS

Fulfills EU RoHS substance requirements	Yes, No exemptions
---	--------------------

China RoHS

Environment friendly use period (EFUP)	EFUP-E
	No hazardous substances above the limits

EU REACH SVHC

REACH candidate substance (CAS No.)	No substance above 0.1 wt%
-------------------------------------	----------------------------

Phoenix Contact 2026 © - all rights reserved
<https://www.phoenixcontact.com>

Phoenix Contact USA
586 Fulling Mill Road
Middletown, PA 17057, United States
(+717) 944-1300
info@phoenixcon.com