

HC-B 6-SMLD-52/M1PG16 A - Housing



1408148

<https://www.phoenixcontact.com/us/products/1408148>

Please be informed that the data shown in this PDF document is generated from our online catalog. Please find the complete data in the user documentation. Our general terms of use for downloads are valid.



HEAVYCON B6 box mounting base, with metal single locking latch, with protective cover, height 52 mm, with screw connection, 1 x Pg16

Commercial data

Item number	1408148
Packing unit	10 pc
Minimum order quantity	20 pc
Product key	AF7AAC
GTIN	4046356565608
Weight per piece (including packing)	278.1 g
Weight per piece (excluding packing)	229.2 g
Country of origin	DE

HC-B 6-SMLD-52/M1PG16 A - Housing



1408148

<https://www.phoenixcontact.com/us/products/1408148>

Technical data

Product properties

Product type	Housing with locking latch
--------------	----------------------------

Environmental and real-life conditions

Ambient conditions

Degree of protection	IP65 (When plugged in)
	IP54 (with closed protective cover)

HC-B 6-SMLD-52/M1PG16 A - Housing



1408148

<https://www.phoenixcontact.com/us/products/1408148>

Drawings

Dimensional drawing

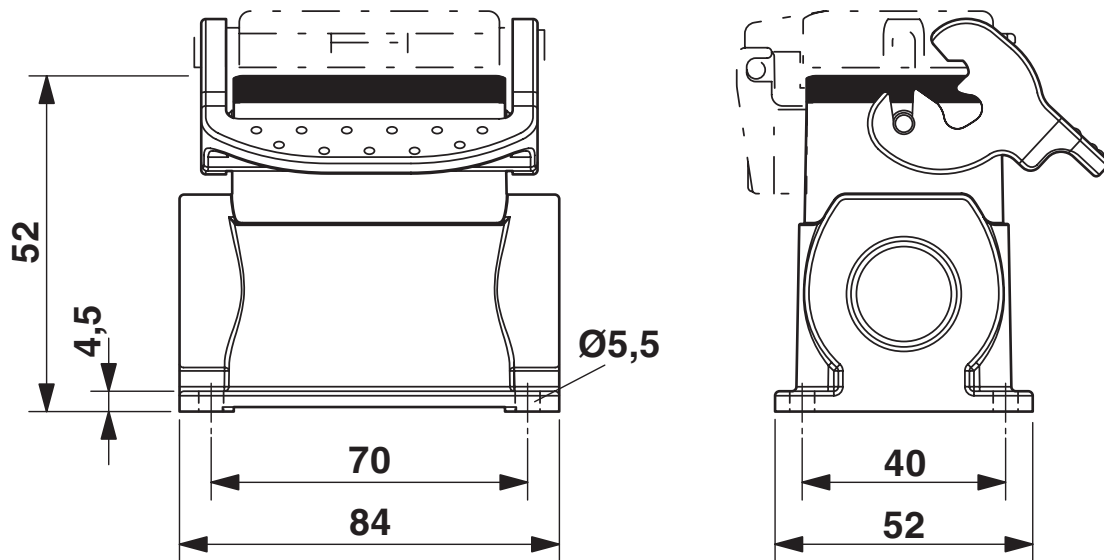

Dimensional drawing

HC-B 6-SMLD-52/M1PG16 A - Housing



1408148

<https://www.phoenixcontact.com/us/products/1408148>

Classifications

ECLASS

ECLASS-13.0	27440202
ECLASS-15.0	27440202

1408148

<https://www.phoenixcontact.com/us/products/1408148>

Environmental product compliance

China RoHS

Environment friendly use period (EFUP)	EFUP-E
	No hazardous substances above the limits

EU REACH SVHC

REACH candidate substance (CAS No.)	No substance above 0.1 wt%
-------------------------------------	----------------------------

Phoenix Contact 2026 © - all rights reserved
<https://www.phoenixcontact.com>

Phoenix Contact USA
586 Fulling Mill Road
Middletown, PA 17057, United States
(+717) 944-1300
info@phoenixcon.com