

VS-IP67/B-IP20-93E-LI/2,0 - Network cable



1405950

<https://www.phoenixcontact.com/us/products/1405950>

Please be informed that the data shown in this PDF document is generated from our online catalog. Please find the complete data in the user documentation. Our general terms of use for downloads are valid.



Assembled Ethernet cable, CAT5e, shielded, 2-pair, AWG 26 stranded (7-wire), RAL 5021 (water blue), RJ45 plug/IP67, black on RJ45 plug/IP20, line, length 2 m

Commercial data

Item number	1405950
Packing unit	1 pc
Minimum order quantity	1 pc
Product key	ABNABD
GTIN	4046356476003
Weight per piece (including packing)	122 g
Weight per piece (excluding packing)	122 g
Country of origin	PL

VS-IP67/B-IP20-93E-LI/2,0 - Network cable



1405950

<https://www.phoenixcontact.com/us/products/1405950>

Technical data

Product properties

Product type	Data cable preassembled
Product family	RJ45 INDUSTRIAL IE4 CAT5
Number of positions	4
No. of cable outlets	1
Number of slots	1
Shielded	yes
Cable outlet	straight

Insulation characteristics

Degree of pollution	2
---------------------	---

Interfaces

Signal type/category	Ethernet CAT5 (IEC 11801:2002)
----------------------	--------------------------------

Electrical properties

Transmission medium	Copper
Transmission characteristics (category)	CAT5 (IEC 11801:2002)

Mechanical properties

Mechanical data

Insertion/withdrawal cycles	≥ 750
-----------------------------	-------

Material specifications

Flammability rating according to UL 94	V2
Outer sheath, material	PUR
Conductor material	Bare Cu litz wires

Connector

Connection 1

Type	Plug straight RJ45
------	--------------------

Connection 2

Type	Plug straight RJ45
------	--------------------

Cable/line

Ethernet flexible CAT5, 2-pair [93E]

VS-IP67/B-IP20-93E-LI/2,0 - Network cable



1405950

<https://www.phoenixcontact.com/us/products/1405950>

Dimensional drawing	
Shielded	yes
UL AWM Style	20963 (80°C/30 V)
Cable weight	42 kg/km
Cable type	Ethernet flexible CAT5, 2-pair
Cable type (abbreviation)	93E
Signal type/category	Ethernet CAT5 (IEC 11801), 100 Mbps
Cable structure	2x2xAWG26/7, SF/UTP
External cable diameter	6.40 mm ±0.2 mm
Outer sheath, material	PUR
External sheath, color	water blue RAL 5021
Thickness, outer sheath	1.20 mm
Conductor material	Bare Cu litz wires
Conductor structure signal line	7x 0.16 mm
AWG signal line	26
Conductor cross-section	2x 2x 0.14 mm ²
Material wire insulation	Foamed PE
Wire diameter incl. insulation	0.98 mm
Single wire, color	white/orange-orange, white/green-green
Twisted pairs	2 cores to the pair
Overall twist	Two pairs with two fillers to the core
Shielding	Aluminum-coated foil, tinned copper braided shield
Optical shield covering	70 %
Current carrying capacity of cable	2.00 A (according to DIN VDE 0891-1)
Nominal voltage, cable	≤ 100 V (Peak value, not for high-power applications)
Test voltage Core/Core	700 V (50 Hz, 1 min.)
Test voltage Core/Shield	700.00 V (50 Hz, 1 min.)
Cable insulation resistance	≥ 500 MΩ*km
Coupling resistance	≤ 100.00 mΩ/m (at 10 MHz)
Wave impedance	100 Ω ±5 Ω (at 100 MHz)
Loop resistance	≤ 290.00 Ω/km
Cable capacity	approx. 45 nF/km (at 1 kHz)
Signal runtime	5.3 ns/m
Tensile strength	≤ 80 N
Minimum bending radius, fixed installation	4 x D
Minimum bending radius, flexible installation	8 x D
	65.3 dB (with 1 MHz)

VS-IP67/B-IP20-93E-LI/2,0 - Network cable



1405950

<https://www.phoenixcontact.com/us/products/1405950>

Near end crosstalk attenuation (NEXT)	56.3 dB (at 4 MHz)
	50.3 dB (at 10 MHz)
	47.2 dB (at 16 MHz)
	45.8 dB (at 20 MHz)
	42.9 dB (at 31.25 MHz)
	38.4 dB (at 62.5 MHz)
	35.3 dB (at 100 MHz)
Power-summated near end crosstalk attenuation (PSNEXT)	62.3 dB (with 1 MHz)
	53.3 dB (at 4 MHz)
	47.3 dB (at 10 MHz)
	44.2 dB (at 16 MHz)
	42.8 dB (at 20 MHz)
	39.9 dB (at 31.25 MHz)
	35.4 dB (at 62.5 MHz)
Return attenuation (RL)	32.3 dB (at 100 MHz)
	23 dB (at 4 MHz)
	24.1 dB (at 8 MHz)
	25 dB (at 10 MHz)
	25 dB (at 16 MHz)
	25 dB (at 20 MHz)
	23.6 dB (at 31.25 MHz)
	21.5 dB (at 62.5 MHz)
20.1 dB (at 100 MHz)	
Halogen-free	according to IEC 60754-1
Resistance to oil	in accordance with EN 60811-2-1
Flame resistance	according to IEC 60332-1-2
	in acc. to UL VW1
Ambient temperature (operation)	in accordance with UN ECE-R 118.03
	-20 °C ... 80 °C (Cable, flexible installation)
	-40 °C ... 80 °C (cable, fixed installation)

Environmental and real-life conditions

Ambient conditions

Degree of protection	IP20
	IP67
	IP67/IP20

VS-IP67/B-IP20-93E-LI/2,0 - Network cable



1405950

<https://www.phoenixcontact.com/us/products/1405950>

Drawings

Dimensional drawing

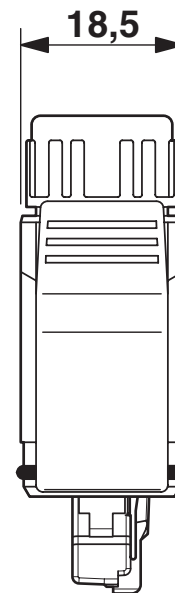
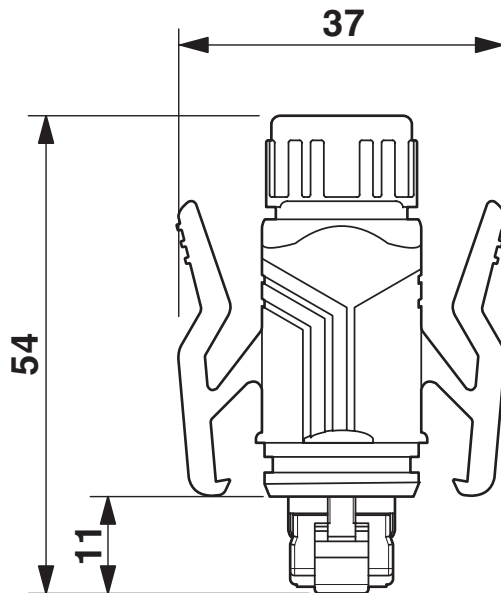

Dimensional drawing

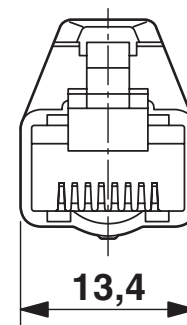
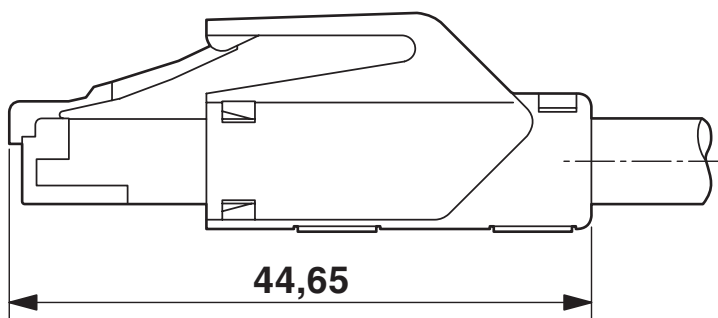

VS-IP67/B-IP20-93E-LI/2,0 - Network cable

1405950

<https://www.phoenixcontact.com/us/products/1405950>



Circuit diagram

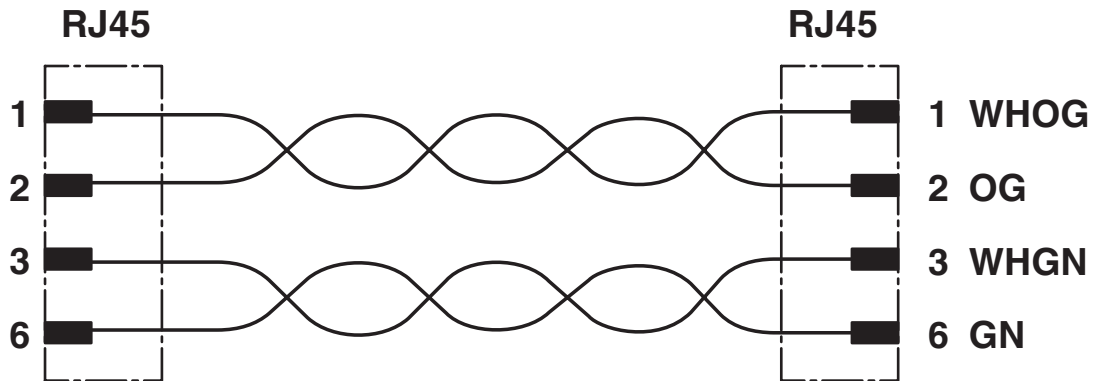

VS-IP67/B-IP20-93E-LI/2,0 - Network cable



1405950

<https://www.phoenixcontact.com/us/products/1405950>

Classifications

ECLASS

ECLASS-13.0	27060307
ECLASS-15.0	27060307

VS-IP67/B-IP20-93E-LI/2,0 - Network cable



1405950

<https://www.phoenixcontact.com/us/products/1405950>

Environmental product compliance

EU RoHS

Fulfills EU RoHS substance requirements	Yes, No exemptions
---	--------------------

China RoHS

Environment friendly use period (EFUP)	EFUP-50
	An article-related China RoHS declaration table can be found in the download area for the respective article under "Manufacturer declaration". For all articles with EFUP-E, no China RoHS declaration table issued and required.

EU REACH SVHC

REACH candidate substance (CAS No.)	No substance above 0.1 wt%
-------------------------------------	----------------------------

Phoenix Contact 2026 © - all rights reserved

<https://www.phoenixcontact.com>

Phoenix Contact USA
586 Fulling Mill Road
Middletown, PA 17057, United States
(+717) 944-1300
info@phoenixcon.com