

QPD QSK 5X2,5 - Protective cap

1404528

<https://www.phoenixcontact.com/us/products/1404528>



Please be informed that the data shown in this PDF document is generated from our online catalog. Please find the complete data in the user documentation. Our general terms of use for downloads are valid.

Protective cap, transparent plastic, for 5x 2.5 mm² QPD QUICKON connection, IP50.



Commercial data

Item number	1404528
Packing unit	10 pc
Minimum order quantity	10 pc
Note	Made to order (non-returnable)
Sales key	BF50
Product key	AF6ZWX
GTIN	4046356698702
Weight per piece (including packing)	2.11 g
Weight per piece (excluding packing)	2.11 g
Customs tariff number	39269097
Country of origin	DE

QPD QSK 5X2,5 - Protective cap

1404528

<https://www.phoenixcontact.com/us/products/1404528>

Technical data

Product properties

Product type	Protective cap
Product family	QPD
Type	QPD
Retaining cord present	no
Seal present	no

Dimensions

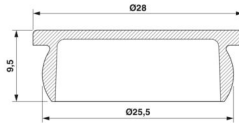
Dimensional drawing	
Width	28 mm
Height	9.5 mm
Length	28 mm

Material specifications

Color	transparent
Material Protective cap	Plastic
Flammability rating according to UL 94	V0

Environmental and real-life conditions

Ambient conditions

Degree of protection	IP50
	IP50
Ambient temperature (operation)	-40 °C ... 80 °C
Ambient temperature (storage/transport)	-40 °C ... 80 °C

QPD QSK 5X2,5 - Protective cap

1404528

<https://www.phoenixcontact.com/us/products/1404528>



Drawings

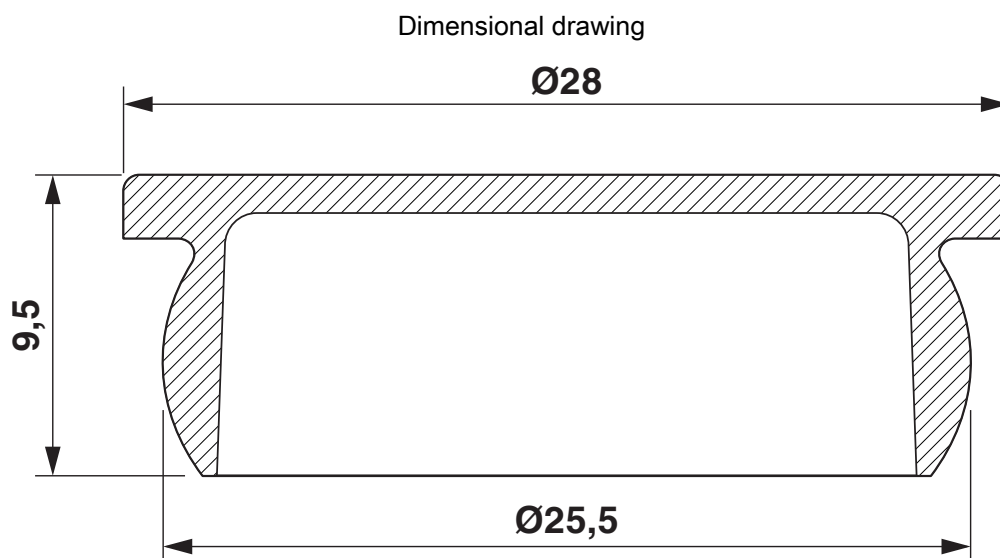

QPD QSK 5X2,5 - Protective cap

1404528

<https://www.phoenixcontact.com/us/products/1404528>



Approvals

To download certificates, visit the product detail page: <https://www.phoenixcontact.com/us/products/1404528>



DNV GL

Approval ID: TAE00003J5

QPD QSK 5X2,5 - Protective cap

1404528

<https://www.phoenixcontact.com/us/products/1404528>



Classifications

ECLASS

ECLASS-13.0	27440208
ECLASS-15.0	27440208

ETIM

ETIM 10.0	EC002314
-----------	----------

UNSPSC

UNSPSC 21.0	39121400
-------------	----------

QPD QSK 5X2,5 - Protective cap



1404528

<https://www.phoenixcontact.com/us/products/1404528>

Environmental product compliance

EU RoHS

Fulfills EU RoHS substance requirements	Yes, No exemptions
---	--------------------

China RoHS

Environment friendly use period (EFUP)	EFUP-E
	No hazardous substances above the limits

EU REACH SVHC

REACH candidate substance (CAS No.)	No substance above 0.1 wt%
-------------------------------------	----------------------------

Phoenix Contact 2026 © - all rights reserved
<https://www.phoenixcontact.com>

Phoenix Contact USA
586 Fulling Mill Road
Middletown, PA 17057, United States
(+717) 944-1300
info@phoenixcon.com