

VS-PNRJ45-PNRJ45-93G-0,3 - Patch cable



1402510

<https://www.phoenixcontact.com/us/products/1402510>

Please be informed that the data shown in this PDF document is generated from our online catalog. Please find the complete data in the user documentation. Our general terms of use for downloads are valid.



EtherCAT® patch cable, shielded, star quad, AWG 22 stranded (7-wire), green, RJ45 plug/IP 20, straight, to RJ45 plug/IP20, straight, length: 0.3 m

EtherCAT® patch cable

Commercial data

Item number	1402510
Packing unit	1 pc
Note	Made to order (non-returnable)
Sales key	NULL
Product key	ABNABA
GTIN	4046356622295
Weight per piece (including packing)	47 g
Weight per piece (excluding packing)	43 g
Customs tariff number	85444210
Country of origin	PL

VS-PNRJ45-PNRJ45-93G-0,3 - Patch cable



1402510

<https://www.phoenixcontact.com/us/products/1402510>

Technical data

Product properties

Product type	Data cable preassembled
Product family	RJ45 INDUSTRIAL PN4 CAT5
Sensor type	EtherCAT®
Number of positions	4

Electrical properties

Rated voltage (III/3)	72 V (DC)
Transmission medium	Copper

Connector

Connection 1

Type	Plug straight RJ45
Handle color	black
Material	CuSn (Contact) Ni/Au (Contact surface) PA (Contact carrier) PA (Housing)
Insertion/withdrawal cycles	≥ 750
Degree of protection	IP20
Ambient temperature (operation)	-25 °C ... 80 °C

Connection 2

Type	Plug straight RJ45
Handle color	black
Material	CuSn (Contact) Ni/Au (Contact surface) PA (Contact carrier) PA (Housing)
Insertion/withdrawal cycles	≥ 750
Degree of protection	IP20
Ambient temperature (operation)	-25 °C ... 80 °C

Cable/line

EtherCAT® [93G]

VS-PNRJ45-PNRJ45-93G-0,3 - Patch cable

1402510

<https://www.phoenixcontact.com/us/products/1402510>

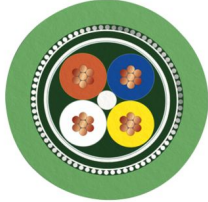
Dimensional drawing	
Shielded	yes
UL AWM Style	21694
Cable weight	67 kg/km
Cable type	EtherCAT®
Cable type (abbreviation)	93G
Signal type/category	EtherCAT® CAT5 (IEC 11801), 100 Mbps
Cable structure	1x4xAWG22/7, SF/TQ
External cable diameter	6.50 mm ±0.2 mm
Outer sheath, material	PVC
External sheath, color	green RAL 6018
Thickness, outer sheath	approx. 0.90 mm
Material, inner sheath	PVC
Conductor material	Tin-plated Cu litz wires
Conductor structure signal line	7x 0.25 mm
AWG signal line	22
Conductor cross-section	4x 0.34 mm ²
Material wire insulation	PE
Wire diameter incl. insulation	1.55 mm
Single wire, color	white, yellow, blue, orange
Overall twist	Star quad
Shielding	Aluminum-coated foil, tinned copper braided shield
Optical shield covering	85 %
Nominal voltage, cable	600 V
Test voltage Core/Core	2000 V (50 Hz, 1 min.)
Test voltage Core/Shield	2000.00 V (50 Hz, 1 min.)
Cable insulation resistance	≥ 500 MΩ*km
Coupling resistance	≤ 20.00 mΩ/m (at 10 MHz)
Wave impedance	100 Ω ±15 Ω (at 100 MHz)
Loop resistance	≤ (per km)
Signal runtime	5.3 ns/m
Signal speed	0.66 c
Minimum bending radius, fixed installation	3 x D
Minimum bending radius, flexible installation	7 x D
Resistance to oil	Resistant to oil to a limited extent
Flame resistance	according to UL 1685 (CSA FT 4)
Other resistance	UV resistant (according to UL 1581, Section 1200)

VS-PNRJ45-PNRJ45-93G-0,3 - Patch cable



1402510

<https://www.phoenixcontact.com/us/products/1402510>

Ambient temperature (operation)	-40 °C ... 70 °C (Cable, flexible installation)
	-40 °C ... 70 °C (cable, fixed installation)

VS-PNRJ45-PNRJ45-93G-0,3 - Patch cable

1402510

<https://www.phoenixcontact.com/us/products/1402510>

Drawings

Dimensional drawing

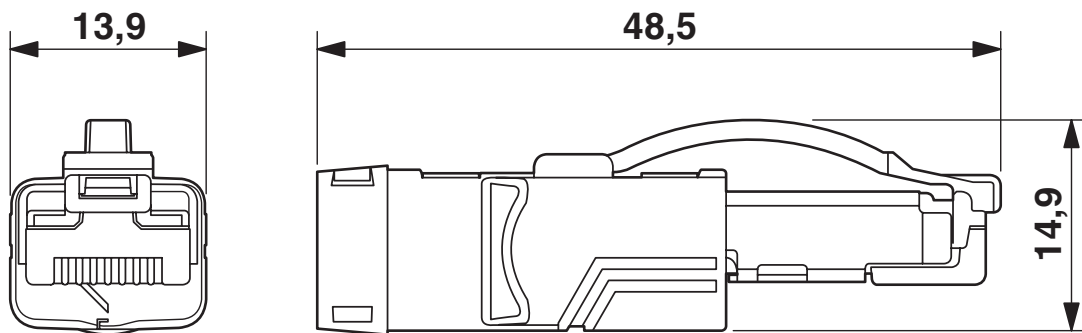

RJ45 connector, IP20

Circuit diagram

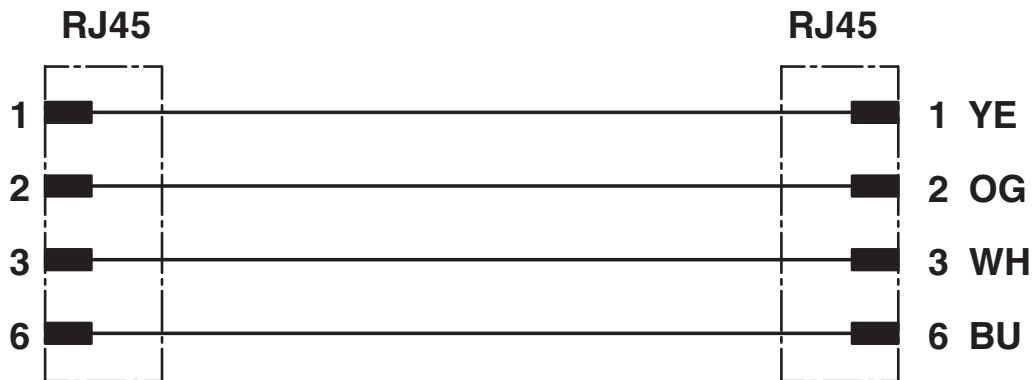

VS-PNRJ45-PNRJ45-93G-0,3 - Patch cable



1402510

<https://www.phoenixcontact.com/us/products/1402510>

Classifications

ECLASS

ECLASS-13.0	27060307
ECLASS-15.0	27060307

VS-PNRJ45-PNRJ45-93G-0,3 - Patch cable



1402510

<https://www.phoenixcontact.com/us/products/1402510>

Environmental product compliance

EU RoHS

Fulfills EU RoHS substance requirements	Yes, No exemptions
---	--------------------

China RoHS

Environment friendly use period (EFUP)	EFUP-E
	No hazardous substances above the limits

EU REACH SVHC

REACH candidate substance (CAS No.)	No substance above 0.1 wt%
-------------------------------------	----------------------------

Phoenix Contact 2026 © - all rights reserved
<https://www.phoenixcontact.com>

Phoenix Contact USA
586 Fulling Mill Road
Middletown, PA 17057, United States
(+717) 944-1300
info@phoenixcon.com