

# CHARX T1HCI12-1AC80-5,0M1 - Vehicle charging inlet



1379294

<https://www.phoenixcontact.com/us/products/1379294>

Please be informed that the data shown in this PDF document is generated from our online catalog. Please find the complete data in the user documentation. Our general terms of use for downloads are valid.



The figure shows a version of the product

CHARX connect universal, AC type 1, Vehicle charging inlet, 80 A , 250 V AC, Single-core wires connected at one end, length: 5 m, locking actuator: 12 V, 4-pos., Front and rear mounting, M6, housing: black, for charging electric vehicles with alternating current (AC), IEC 62196-2, SAE J1772, A protective cap is supplied as standard for the AC contacts.

## Product description

Vehicle charging inlet for charging with alternating current (AC), compatible with type 1 AC vehicle charging connectors (EVSE), for installation in electric vehicles (EV).

## Your advantages

- Complete product range
- Uniform, space-saving dimensions for the installation space and the screw connection points of all Phoenix Contact vehicle charging inlets
- Developed and produced in accordance with the IATF 16949 automotive standard and ISO 9001
- Integrated interlock during charging
- Manual emergency release of the locking actuator
- Protected and sealed against dirt and water with a high degree of protection

## Commercial data

Item number	1379294
Packing unit	1 pc
Minimum order quantity	1 pc
Sales key	EM01
Product key	XWCAIA
GTIN	4063151747770
Weight per piece (including packing)	2,379 g
Weight per piece (excluding packing)	2,379 g
Customs tariff number	85444290
Country of origin	PL

# CHARX T1HCI12-1AC80-5,0M1 - Vehicle charging inlet



1379294

<https://www.phoenixcontact.com/us/products/1379294>

## Technical data

### Notes

General	A protective cap is supplied as standard for the AC contacts.
---------	---

### Product properties

Product type	Vehicle charging inlet
Product family	CHARX connect universal
Charging standard	AC type 1
Charging mode	Mode 2, 3
Customer variations	On request

### Electrical properties

#### Charging power and current (AC charging, 1-phase)

Type of charging current	AC single-phase
Charging current	80 A AC (1-phase)
Charging power	20 kW

#### Pin assignment (Power contacts)

Note on the connection method	Crimp connection, cannot be disconnected
Number	3 (L1, N, PE)
Rated voltage	250 V AC
Rated current	80 A AC

#### Pin assignment (Signal contacts)

Note on the connection method	Crimp connection, cannot be disconnected
Type of signal transmission	Pulse width modulation with modulated Powerline communication in accordance with ISO/IEC 15118 / DIN SPEC 70121
Number	2 (CP, CS)
Rated voltage	30 V AC
Rated current	2 A
Coding	2.7 k $\Omega$ (between PE and CS)
Insulation resistance	> 200 M $\Omega$

#### Locking actuator

Locking actuator	12 V, 4-pos.
	Top center position
Possible power supply range at the motor	9 V ... 16 V
Maximum voltage for locking detection	12 V
Typical motor current for locking	0.25 A
Reverse current of the motor	max. 1.5 A
Max. dwell time with reverse current	1 s
Recommended adaptation time	600 ms
Pause time after entry or exit path	3 s

# CHARX T1HCI12-1AC80-5,0M1 - Vehicle charging inlet



1379294

<https://www.phoenixcontact.com/us/products/1379294>

Service life insertion cycles	> 10000 load cycles
Lock recognition	available
Mechanical emergency release	available
Ambient temperature (operation)	-40 °C ... 80 °C

## Temperature sensors (PTC chain)

Sensor type	PTC chain
Standards/regulations	DIN EN 60738-1
Attachment point	Sensor for the AC contacts
Measuring range_resistance	790 Ω ... 1420 Ω
Resistance	max. 1200 Ω ±5 K
Recommended measured current	≤ 1 mA (U <sub>max</sub> = 16 V DC)
Ambient temperature	-40 °C ... 130 °C (Operation)

## Dimensions

### Vehicle charging inlet

Width	90 mm
Height	90 mm
Depth	112.2 mm

### Bore dimensions

Width	73 mm
Height	73 mm
Depth	73 mm

## Material specifications

Color (Housing)	black (9005)
Color (Mating face)	black (9005)
Material (Housing)	Plastic
Material (Contact surface)	Silver

## Cable/line

Cable length	5 m
Cable type	Single-core wires connected at one end

### Single-core wires for AC

Cable length	5 m
Cable structure	2 x 16 mm <sup>2</sup>
Single wire, material	Silicone
Single wire, color	OG
External cable diameter	9.90 mm ±0.3 mm
Cable resistance	≤ 1.16 Ω/km

### Single-core wire for PE

Cable length	5 m
Cable structure	1 x 16 mm <sup>2</sup>

# CHARX T1HCI12-1AC80-5,0M1 - Vehicle charging inlet



1379294

<https://www.phoenixcontact.com/us/products/1379294>

Single wire, material	Silicone
Single wire, color	GN/YE
External cable diameter	7.00 mm ±0.2 mm
Cable resistance	≤ 1.16 Ω/km

## Single-core wires for locking actuator

Cable length	1.5 m
Cable structure	4 x 0.5 mm <sup>2</sup>
Single wire, material	PVC
Single wire, color	BU/RD, BU/GN, BU/YE, BU/BN
External cable diameter	1.60 mm ±0.20 mm
Cable resistance	≤ 37.1 Ω/m

## Single-core wires for temperature sensors

Cable length	1 m
Cable structure	5 x 0,5 mm <sup>2</sup>
Single wire, color	BN/GY BN/YE/GN
External cable diameter	1.60 mm ±0.20 mm
Cable resistance	≤ 37.1 Ω/m

## Single-core wires for communication

Cable length	1 m
Cable structure	2 x 0.5 mm <sup>2</sup>
Single wire, material	PVC
Single wire, color	BK WH
External cable diameter	1.60 mm ±0.20 mm
Cable resistance	≤ 37.1 Ω/m

## Mechanical properties

### Mechanical data

Insertion/withdrawal cycles	> 10000
Insertion force	< 75 N
Withdrawal force	< 75 N

## Environmental and real-life conditions

### Ambient conditions

Degree of protection (Vehicle charging inlet)	IP55 (plugged in; when plugged in and ready to operate, the degree of protection is only ensued if both plug-in components are original products from Phoenix Contact or suitable standard-compliant products) IP67 (Inner area of vehicle charging inlet)
Ambient temperature (operation)	-40 °C ... 60 °C
Ambient temperature (storage/transport)	-40 °C ... 85 °C

# CHARX T1HCI12-1AC80-5,0M1 - Vehicle charging inlet



1379294

<https://www.phoenixcontact.com/us/products/1379294>

Altitude	4000 m (above sea level)
----------	--------------------------

## Standards and regulations

### Standards

Standards/regulations	IEC 62196-2
	SAE J1772

## Mounting

Mounting type	Front and rear mounting (0 to 90 degree frontal inclination possible)
Mounting hole diameter	6.70 mm (ø)
Fixing screws	M6
Screws included in the scope of delivery	none

# CHARX T1HCI12-1AC80-5,0M1 - Vehicle charging inlet

1379294

<https://www.phoenixcontact.com/us/products/1379294>

## Drawings

Dimensional drawing

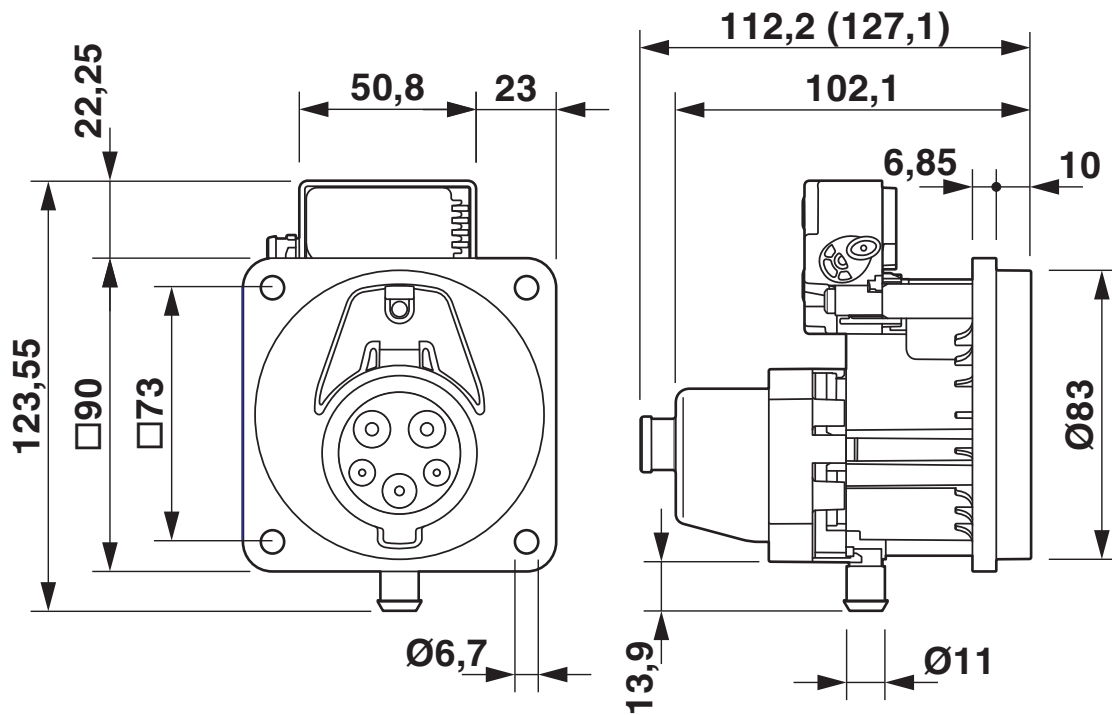

Dimensional drawing

Connection diagram

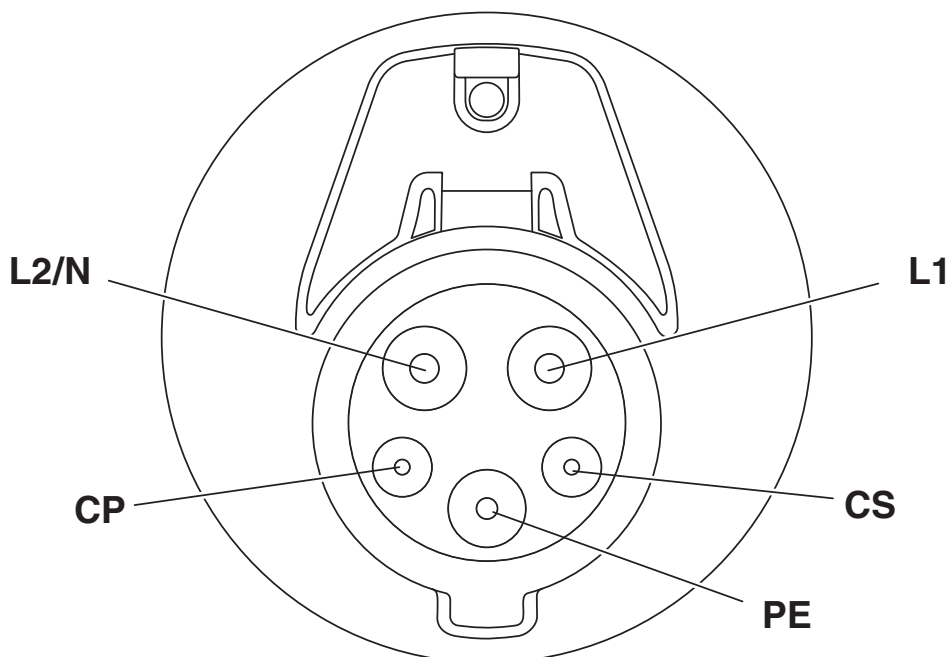

Pin assignment of vehicle charging inlets

# CHARX T1HCI12-1AC80-5,0M1 - Vehicle charging inlet



1379294

<https://www.phoenixcontact.com/us/products/1379294>

Connection diagram

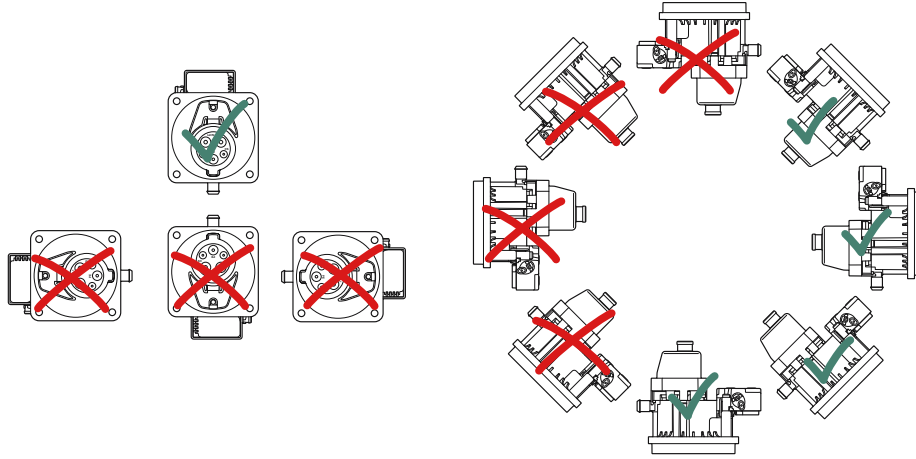

Installation positions

Connection diagram

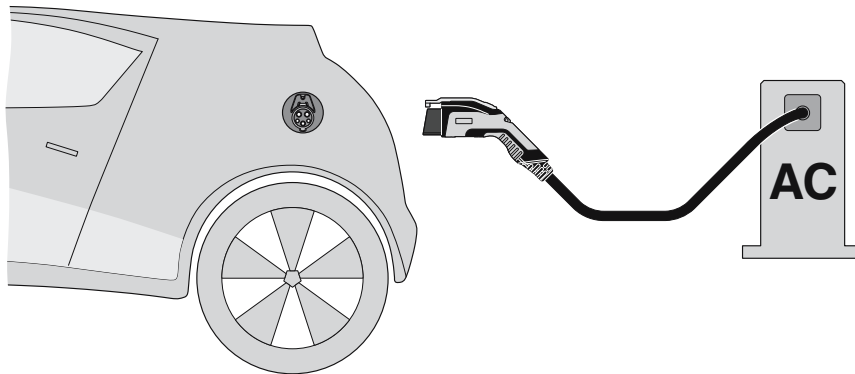

Terminology definition

# CHARX T1HCI12-1AC80-5,0M1 - Vehicle charging inlet

1379294

<https://www.phoenixcontact.com/us/products/1379294>

## Functional drawing

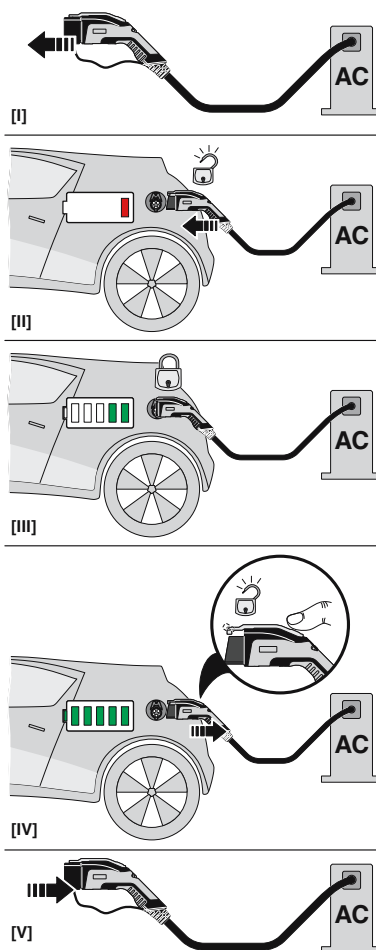

Operating instructions

# CHARX T1HCI12-1AC80-5,0M1 - Vehicle charging inlet

1379294

<https://www.phoenixcontact.com/us/products/1379294>

Schematic diagram

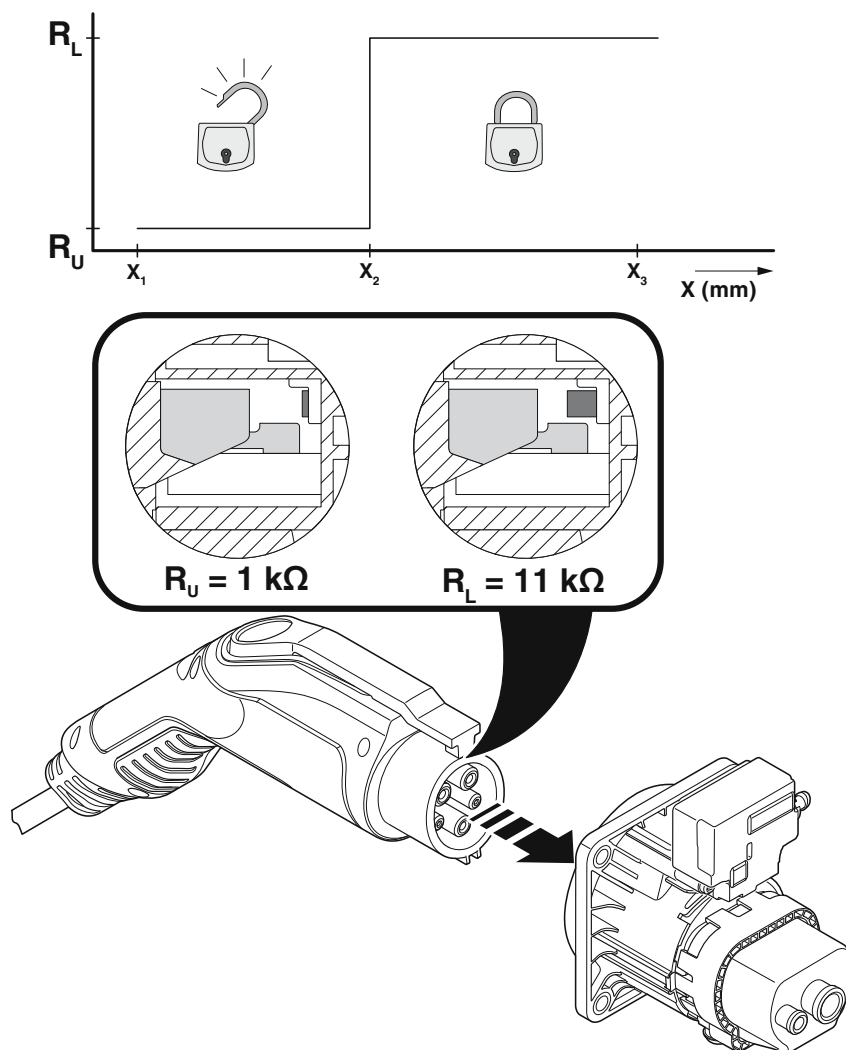

Detection for Vehicle Connector

# CHARX T1HCI12-1AC80-5,0M1 - Vehicle charging inlet



1379294

<https://www.phoenixcontact.com/us/products/1379294>

Schematic diagram



Block diagram of the locking actuator

Schematic diagram



Temperature sensor technology resistance range at AC contacts

# CHARX T1HCI12-1AC80-5,0M1 - Vehicle charging inlet

1379294

<https://www.phoenixcontact.com/us/products/1379294>



Locking states of the locking actuator

# CHARX T1HCI12-1AC80-5,0M1 - Vehicle charging inlet



1379294

<https://www.phoenixcontact.com/us/products/1379294>

## Classifications

### ECLASS

ECLASS-13.0	27144706
ECLASS-15.0	27144706

### ETIM

ETIM 10.0	EC002898
-----------	----------

### UNSPSC

UNSPSC 21.0	39121800
-------------	----------

# CHARX T1HCI12-1AC80-5,0M1 - Vehicle charging inlet



1379294

<https://www.phoenixcontact.com/us/products/1379294>

## Environmental product compliance

### EU RoHS

Fulfills EU RoHS substance requirements	Yes
Exemption	6(c), 7(c)-I

### China RoHS

Environment friendly use period (EFUP)	EFUP-50
	An article-related China RoHS declaration table can be found in the download area for the respective article under "Manufacturer declaration". For all articles with EFUP-E, no China RoHS declaration table issued and required.

### EU REACH SVHC

REACH candidate substance (CAS No.)	Lead(CAS: 7439-92-1)
	Bis(2-(2-methoxyethoxy)ethyl)ether(CAS: 143-24-8)
	6,6'-di-tert-butyl-2,2'-methylenedi-p-cresol(CAS: 119-47-1)
SCIP	58ca9b1d-ee5f-4426-9dc5-503c1bbd7a5f

### EF3.1 Climate Change

CO2e kg	55.59 kg CO2e
---------	---------------

Phoenix Contact 2026 © - all rights reserved

<https://www.phoenixcontact.com>

Phoenix Contact USA  
586 Fulling Mill Road  
Middletown, PA 17057, United States  
(+717) 944-1300  
[info@phoenixcon.com](mailto:info@phoenixcon.com)