

EV-T2SC-EM-WL - Protective cover

1324633

<https://www.phoenixcontact.com/us/products/1324633>

Please be informed that the data shown in this PDF document is generated from our online catalog. Please find the complete data in the user documentation. Our general terms of use for downloads are valid.



CHARX connect basic, Type 2, Protective cover, Gen 1, Accessories, square, Front mounting, housing: black, with self-locking mechanism, for attachment to infrastructure charging sockets, Without logo, IEC 62196-2

Figure shows an item with Phoenix Contact logo

Product description

Self-closing protective cover for infrastructure charging socket

Your advantages

- Developed and produced in accordance with the IATF 16949 automotive standard and ISO 9001
- Individual branding, thanks to the use your own logo
- Reliable protection of your socket outlet from weather and vandalism
- Extremely easy assembly, thanks to a front-side screw connection
- Reduced assembly work, thanks to the pre-injected seal
- No separate panel mounting frame required

Commercial data

Item number	1324633
Packing unit	1 pc
Minimum order quantity	1 pc
Sales key	EM01
Product key	XWBFAC
GTIN	4063151613877
Weight per piece (including packing)	120 g
Weight per piece (excluding packing)	120 g
Customs tariff number	39269097
Country of origin	PL

EV-T2SC-EM-WL - Protective cover



1324633

<https://www.phoenixcontact.com/us/products/1324633>

Technical data

Product properties

Product type	Protective cover for Socket Outlet
Product family	CHARX connect basic
Type	Gen 1 Accessories
Design	with self-locking mechanism
Charging standard	Type 2
Charging mode	Mode 3, Case B
Design (Protective cover)	square
Affixed logo	Without logo
Customer variations	On request

Dimensions

Protective cover

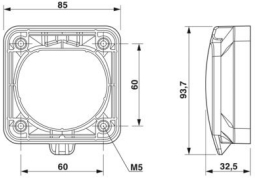
Dimensional drawing	 <p>Dimensional drawing</p>
Width	85 mm
Height	93.7 mm
Depth	32.5 mm

Bore dimensions

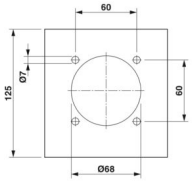
Dimensional drawing	 <p>Hole image</p>
Width	60 mm
Height	60 mm

Material specifications

Color (Housing)	black (9005)
Material (Housing)	Plastic

Environmental and real-life conditions

EV-T2SC-EM-WL - Protective cover



1324633

<https://www.phoenixcontact.com/us/products/1324633>

Ambient conditions

Degree of protection (Protective cover)	IP54
	IK08
Ambient temperature (operation)	-30 °C ... 50 °C
Ambient temperature (storage/transport)	-40 °C ... 80 °C

Standards and regulations

Standards/specifications	IEC 62196-2
Note	Compliant with AFIR - EU 2025/656

Mounting

Mounting type Protective cover	Front mounting (front screw connection)
Screws included in the scope of delivery	M4 cylinder head screws Torx-Plus 10IPR

EV-T2SC-EM-WL - Protective cover



1324633

<https://www.phoenixcontact.com/us/products/1324633>

Drawings

Dimensional drawing

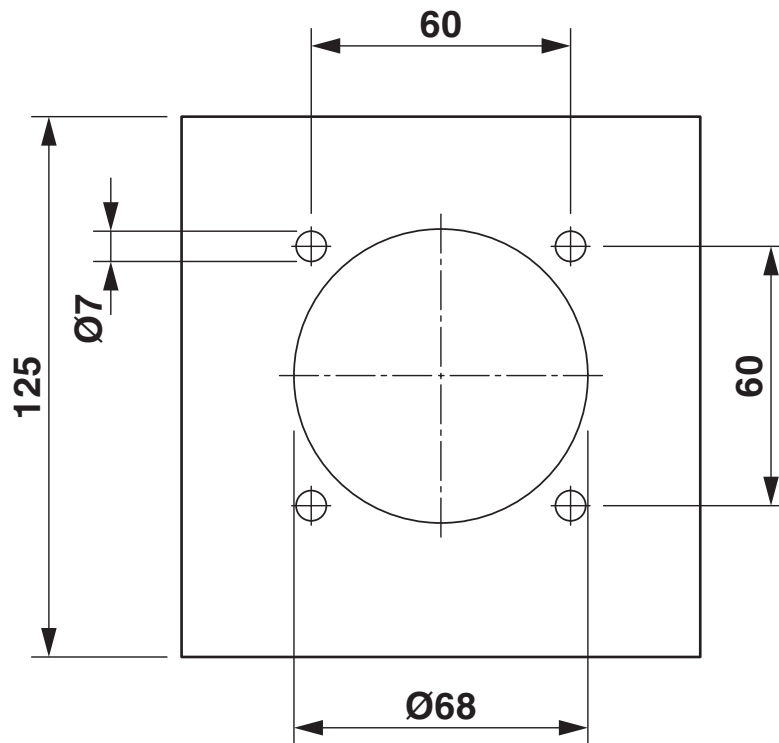

Hole image

EV-T2SC-EM-WL - Protective cover

1324633

<https://www.phoenixcontact.com/us/products/1324633>



Dimensional drawing

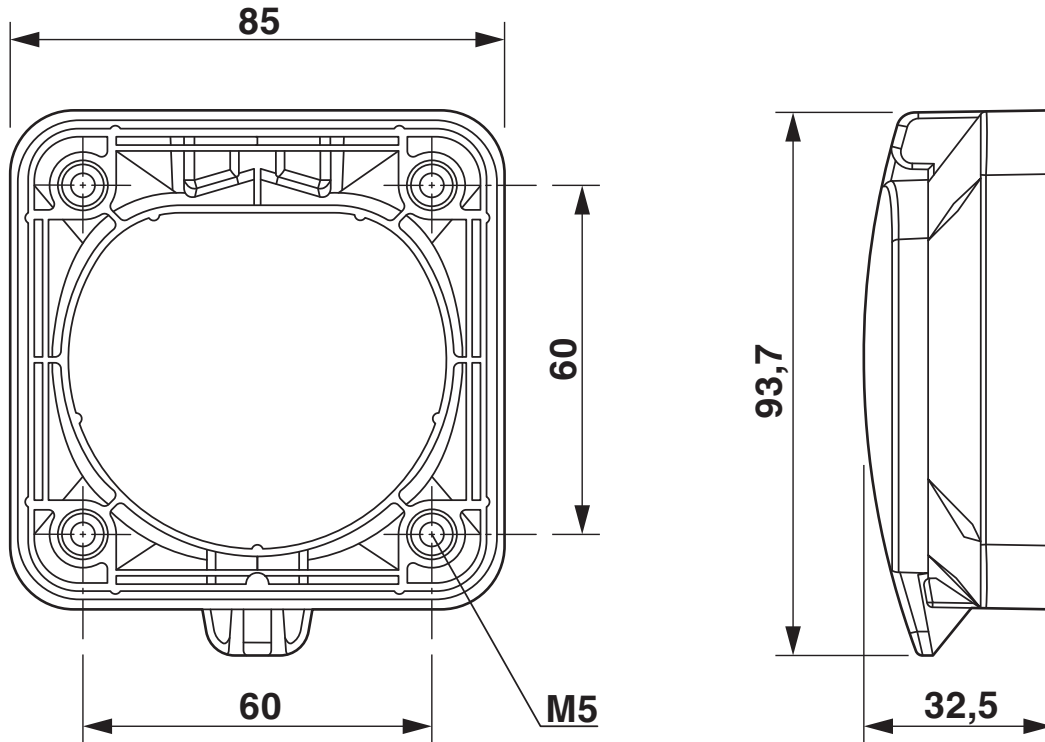

Dimensional drawing

EV-T2SC-EM-WL - Protective cover

1324633

<https://www.phoenixcontact.com/us/products/1324633>

Schematic diagram

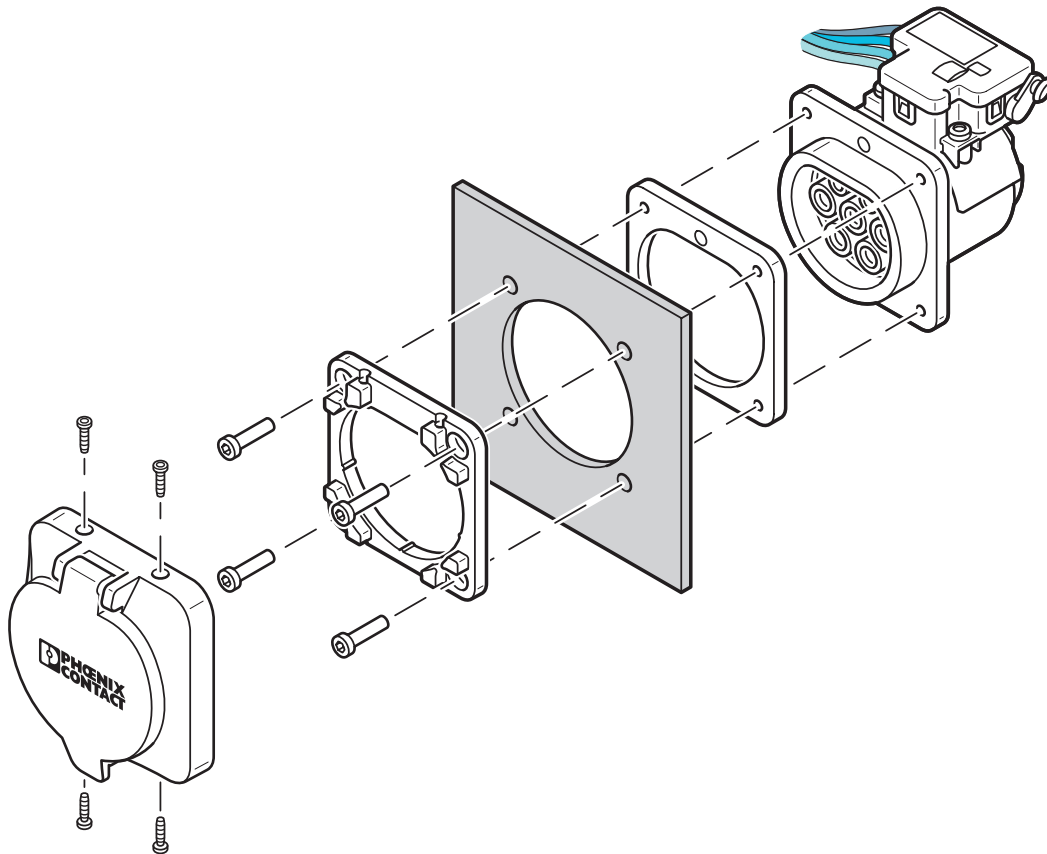

Rear mounting with front protective cover screw connection

The screw connection for a protective cover (EV-T2SC-EM) from the accessories range only supports front mounting with a corresponding fixing frame (EV-T2SF-EM). The panel thickness must not exceed 5 mm. The sealing frame that is slid on from the rear must contact the housing panel flush with the flat side and must completely surround the infrastructure socket outlet.

EV-T2SC-EM-WL - Protective cover



1324633

<https://www.phoenixcontact.com/us/products/1324633>

Classifications

ECLASS

ECLASS-13.0	27144792
ECLASS-15.0	27144792

ETIM

ETIM 10.0	EC002884
-----------	----------

UNSPSC

UNSPSC 21.0	39121500
-------------	----------

EV-T2SC-EM-WL - Protective cover



1324633

<https://www.phoenixcontact.com/us/products/1324633>

Environmental product compliance

EU RoHS

Fulfills EU RoHS substance requirements	Yes, No exemptions
---	--------------------

China RoHS

Environment friendly use period (EFUP)	EFUP-E
	No hazardous substances above the limits

EU REACH SVHC

REACH candidate substance (CAS No.)	No substance above 0.1 wt%
-------------------------------------	----------------------------

Phoenix Contact 2026 © - all rights reserved
<https://www.phoenixcontact.com>

Phoenix Contact USA
586 Fulling Mill Road
Middletown, PA 17057, United States
(+717) 944-1300
info@phoenixcon.com