

ECS-KIT-64X80-S-UV-7042 - Electronics housing



1319373

<https://www.phoenixcontact.com/us/products/1319373>

Please be informed that the data shown in this PDF document is generated from our online catalog. Please find the complete data in the user documentation. Our general terms of use for downloads are valid.



Empty enclosure for wall or mast mounting, gray (7042), modular electronics housing with front plate, for outdoor applications, degree of protection: IP66/IP67/IP68/IP69, width: 97 mm, height: 87 mm, depth: 42 mm, PCB surface: 4100 mm²

Your advantages

- Housing design supports the installation of a range of PCB thicknesses for high application diversity
- Integrated pressure compensation membrane for fluctuating ambient pressures
- Optional accessories for wall and mast mounting
- Proven PCB connection technology
- Integrated tamper protection
- Effective protection of electronics against thermal and mechanical influences
- Suitable for outdoor/indoor applications

Commercial data

| | |
|--------------------------------------|---------------|
| Item number | 1319373 |
| Packing unit | 1 pc |
| Minimum order quantity | 1 pc |
| Sales key | AC04 |
| Product key | ACFDAK |
| GTIN | 4063151604424 |
| Weight per piece (including packing) | 142 g |
| Weight per piece (excluding packing) | 144.5 g |
| Customs tariff number | 84879090 |
| Country of origin | US |

1319373

<https://www.phoenixcontact.com/us/products/1319373>

Technical data

Notes

| | |
|---------------|--|
| Assembly note | Please observe the assembly instructions available in the download area. |
|---------------|--|

Product properties

| | |
|------------------------------|-----------------------|
| Product type | Stackable housing set |
| Housing type | Field housing |
| Housing type | Outdoor housings |
| Housing series | ECS |
| Ventilation openings present | no |
| Battery compartment | no |

Dimensions

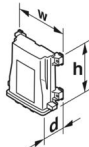
| | |
|---------------------|--|
| Dimensional drawing |  |
| Width | 97.8 mm |
| Height | 89.4 mm |
| Depth | 45.1 mm |

Material specifications

| | |
|--|-----------------|
| Color (Housing) | gray (RAL 7042) |
| Material Housing | PC |
| Flammability rating according to UL 94 | V0 |

Environmental and real-life conditions

Ambient conditions

| | |
|---|-------------------|
| Max. NEMA code to attain | 6 |
| Ambient temperature (operation) | -40 °C ... 100 °C |
| Ambient temperature (storage/transport) | -40 °C ... 100 °C |

PCB data

| | |
|-----------------------|----------------------|
| Number of PCB holders | 1 |
| Type of PCB mount | Bolt mounting |
| Total PCB surface | 4100 mm ² |

Mounting

| | |
|---------------|---|
| Mounting type | Wall or panel mount. Pole mount with accessory. |
|---------------|---|

ECS-KIT-64X80-S-UV-7042 - Electronics housing



1319373

<https://www.phoenixcontact.com/us/products/1319373>

Packaging specifications

| | |
|----------------------|---------------------|
| Type of packaging | packed in cardboard |
| Outer packaging type | Carton |

1319373

<https://www.phoenixcontact.com/us/products/1319373>

Drawings

Dimensional drawing

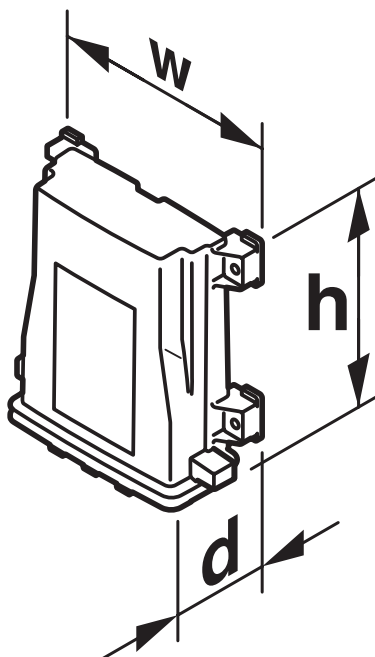

Schematic figure for illustrating the item dimensions. The figure is not of the desired product. For further details, refer to the product drawings in the "Downloads" tab.

1319373

<https://www.phoenixcontact.com/us/products/1319373>

Classifications

ECLASS

| | |
|-------------|----------|
| ECLASS-13.0 | 27190103 |
| ECLASS-15.0 | 27190103 |

ETIM

| | |
|-----------|----------|
| ETIM 10.0 | EC001031 |
|-----------|----------|

UNSPSC

| | |
|-------------|----------|
| UNSPSC 21.0 | 31261500 |
|-------------|----------|

1319373

<https://www.phoenixcontact.com/us/products/1319373>

Environmental product compliance

EU RoHS

| | |
|---|--------------------|
| Fulfills EU RoHS substance requirements | Yes, No exemptions |
|---|--------------------|

China RoHS

| | |
|--|--|
| Environment friendly use period (EFUP) | EFUP-E |
| | No hazardous substances above the limits |

EU REACH SVHC

| | |
|-------------------------------------|----------------------------|
| REACH candidate substance (CAS No.) | No substance above 0.1 wt% |
|-------------------------------------|----------------------------|

Phoenix Contact 2026 © - all rights reserved
<https://www.phoenixcontact.com>

Phoenix Contact USA
586 Fulling Mill Road
Middletown, PA 17057, United States
(+717) 944-1300
info@phoenixcon.com