

SF-ASD 16/ACCU 2,0 AH - Battery module



1314530

<https://www.phoenixcontact.com/us/products/1314530>

Please be informed that the data shown in this PDF document is generated from our online catalog. Please find the complete data in the user documentation. Our general terms of use for downloads are valid.

Replacement battery, 2.0 Ah, lithium-ion, 3.6 V, for SF-ASD 16 cordless screwdriver



Your advantages

- Reverse polarity protected
- 3.6 V

Commercial data

Item number	1314530
Packing unit	1 pc
Minimum order quantity	1 pc
Sales key	BH32
Product key	BH324Y
GTIN	4063151579005
Weight per piece (including packing)	111.3 g
Weight per piece (excluding packing)	111.3 g
Customs tariff number	85076000
Country of origin	TW

SF-ASD 16/ACCU 2,0 AH - Battery module



1314530

<https://www.phoenixcontact.com/us/products/1314530>

Technical data

Product properties

Product type	Battery module
Type of packaging	packed in cardboard
Battery-operated voltage	3.6 V
Battery charging	60 min

Insulation characteristics

Protection class	II
------------------	----

Electrical properties

Power consumption	7.2 W
Nominal voltage U_N	3.6 V DC
	3.6 V DC

Battery

Battery charging	60.00 min
Battery-operated voltage	3.60 V DC
Battery capacity	2.00 Ah

Dimensions

Length	82 mm
Diameter	43 mm

Material specifications

Color	multicolored (RAL -)
-------	----------------------

Environmental and real-life conditions

Ambient conditions

Ambient temperature (operation)	5 °C ... 40 °C
Ambient temperature (storage/transport)	-25 °C ... 60 °C
Permissible humidity (operation)	95 % (<)

Drawings

Schematic diagram

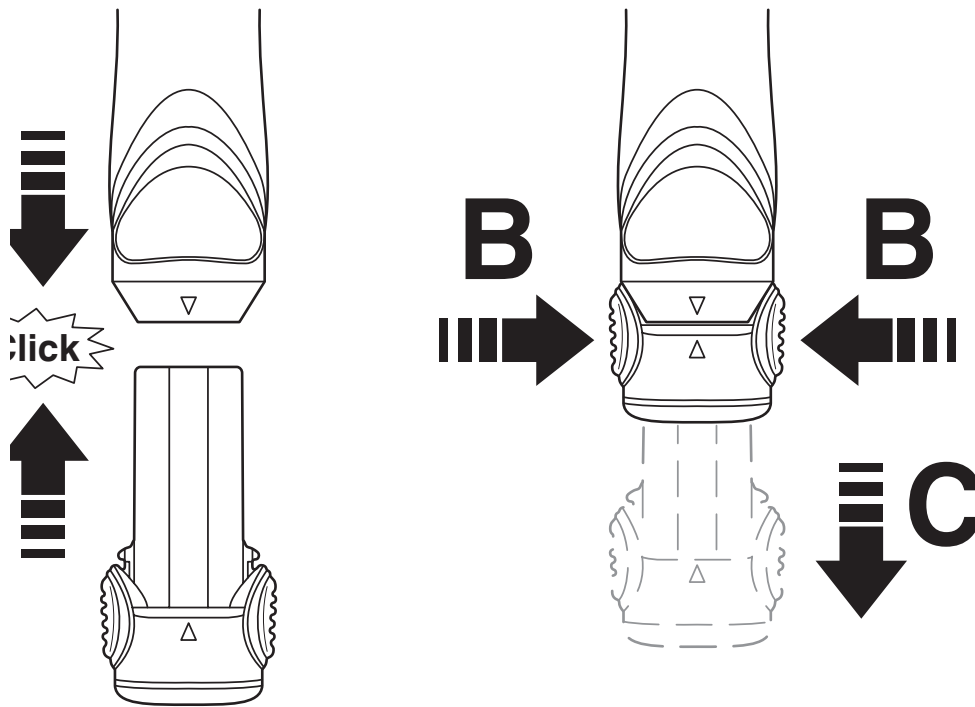

Schematic diagram

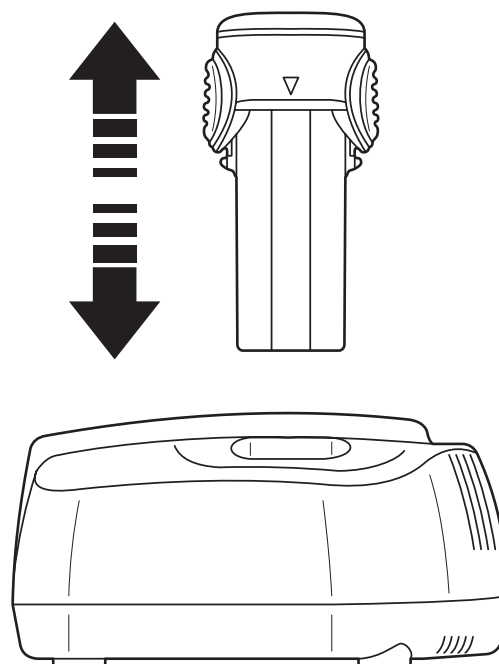

SF-ASD 16/ACCU 2,0 AH - Battery module



1314530

<https://www.phoenixcontact.com/us/products/1314530>

Approvals

To download certificates, visit the product detail page: <https://www.phoenixcontact.com/us/products/1314530>



EAC

Approval ID: RU C-DE.AI30.B.01750

SF-ASD 16/ACCU 2,0 AH - Battery module



1314530

<https://www.phoenixcontact.com/us/products/1314530>

Classifications

ECLASS

ECLASS-13.0	21052902
ECLASS-15.0	21052902

ETIM

ETIM 10.0	EC001199
-----------	----------

UNSPSC

UNSPSC 21.0	26111700
-------------	----------

SF-ASD 16/ACCU 2,0 AH - Battery module



1314530

<https://www.phoenixcontact.com/us/products/1314530>

Environmental product compliance

EU RoHS

Fulfills EU RoHS substance requirements	Not applicable, No electrical and electronic equipment (EEE), cannot be used in EEE
---	---

China RoHS

Environment friendly use period (EFUP)	EFUP-5
	An article-related China RoHS declaration table can be found in the download area for the respective article under "Manufacturer declaration". For all articles with EFUP-E, no China RoHS declaration table issued and required.

EU REACH SVHC

REACH candidate substance (CAS No.)	No substance above 0.1 wt%
-------------------------------------	----------------------------

EF3.1 Climate Change

CO2e kg	6.208 kg CO2e
---------	---------------

Phoenix Contact 2026 © - all rights reserved
<https://www.phoenixcontact.com>

Phoenix Contact USA
586 Fulling Mill Road
Middletown, PA 17057, United States
(+717) 944-1300
info@phoenixcon.com