

MACX MCR-EX-AP-RTD-RTD - Temperature measuring transducer



1291894

<https://www.phoenixcontact.com/us/products/1291894>

Please be informed that the data shown in this PDF document is generated from our online catalog. Please find the complete data in the user documentation. Our general terms of use for downloads are valid.



Ex i-Resistance isolator for intrinsically safe operation of Pt 100 resistance thermometers in 2, 3, or 4-conductor technology and resistance-type sensors. The values measured at the Ex i input are transmitted 1:1 to the non Ex i output. number of channels: 1, Standard configuration, 3-way isolation, Screw connection

Commercial data

Item number	1291894
Packing unit	1 pc
Minimum order quantity	1 pc
Sales key	C430
Product key	DK121W
GTIN	4063151524333
Weight per piece (including packing)	202.9 g
Weight per piece (excluding packing)	202.9 g
Customs tariff number	85437090
Country of origin	DE

MACX MCR-EX-AP-RTD-RTD - Temperature measuring transducer



1291894

<https://www.phoenixcontact.com/us/products/1291894>

Technical data

Notes

Note on application	Accuracy, typically specified as a percentage of the basic measuring range at U_N , 23°C
Notes on operation	Installation conditions influence the ambient temperature. Please refer to the "Control cabinet installation instructions".
Notes on operation	Sensor set via DIP switches
Notes on operation	2-conductor comparison set via DIP switch ADJ

Product properties

Product type	Temperature transmitter
Product family	MACX Analog
No. of channels	1

Electrical properties

Electrical isolation	3-way isolation
Electrical isolation between input and output	yes
Signal transmission behavior	In = Out
Temperature coefficient, typical	≤ 0.1 % (10 K)
Reverse polarity protection	yes

Electrical isolation Input/output IEC/EN 60079-11

Standards/regulations	IEC/EN 60079-11
Rated insulation voltage	375 V _{PP}

Electrical isolation Input/power supply IEC/EN 60079-11

Standards/regulations	IEC/EN 60079-11
Rated insulation voltage	375 V _{PP}

Electrical isolation Input/error message output IEC/EN 60079-11

Standards/regulations	IEC/EN 60079-11
Rated insulation voltage	375 V _{PP}

Electrical isolation Input/configuration interface IEC/EN 60079-11

Standards/regulations	IEC/EN 60079-11
Rated insulation voltage	375 V _{PP}

Electrical isolation Output 1/output 2

Test voltage	350 V (50 Hz, 60 s)
--------------	---------------------

Electrical isolation Output/supply

Test voltage	350 V (50 Hz, 60 s)
--------------	---------------------

Electrical isolation Output/configuration interface

Test voltage	350 V (50 Hz, 60 s)
--------------	---------------------

MACX MCR-EX-AP-RTD-RTD - Temperature measuring transducer



1291894

<https://www.phoenixcontact.com/us/products/1291894>

Electrical isolation Output/supply/error message output

Test voltage	350 V (50 Hz, 60 s)
--------------	---------------------

Supply

Nominal supply voltage	24 V DC
Supply voltage range	18 V ... 31.2 V
Power dissipation	≤ 600 mW
Power consumption	≤ 650 mW

Input data

Measurement

Description of the input	intrinsically safe
Sensor types (RTD) that can be used	Pt 100
Connection technology	2-, 3-, 4-conductor
Linear resistance measuring range	18 Ω ... 391 Ω (Pt 100)
Max. permissible overall conductor resistance	≤ 50 Ω (per wire, 2-conductor circuit) ≤ 100 Ω (per wire, 3-, 4-conductor circuit)

Output data

Analog: Resistance thermometer

Output signal Voltage	2 V DC (Nominal voltage)
Output signal Current	5 mA (Nominal current)
Output signal Resistance	400 Ω
Output signal Resistance range	18 Ω ... 391 Ω (Pt 100)
Settling time	< 10 ms (10% ... 90%, multiplexer mode)
Setting range	< 1 s (Input/output)
Sensor input current	200 μA ... 5 mA
Connection technology	2-, 3-, 4-conductor

Signal: Error message output

Maximum switching voltage	30 V
Max. switching current	100 mA

Connection data

Connection method	Screw connection
Stripping length	7 mm
Screw thread	M3
Conductor cross-section rigid	0.2 mm ² ... 2.5 mm ²
Conductor cross-section flexible	0.2 mm ² ... 2.5 mm ²
Conductor cross-section AWG	24 ... 14
Tightening torque	0.5 Nm ... 0.6 Nm

MACX MCR-EX-AP-RTD-RTD - Temperature measuring transducer

1291894

<https://www.phoenixcontact.com/us/products/1291894>

Ex data

Ex installation (EPL)	Gc
Ex i circuits (EPL)	[Ga]
	[Da]
	[Ma]

Safety data

Max. internal inductance L_i	negligible
Max. internal capacitance C_i	negligible
Max. output voltage U_o	6.5 V
Max. output current I_o	16.5 mA
Max. output power P_o	27 mW
Safety-related maximum voltage U_m	253 V AC
IIA (simple circuit): Max. external inductivity L_o / Max. external capacitance C_o	900 mH / 1000 μ F
IIB/IIIC (simple circuit): Max. external inductivity L_o / Max. external capacitance C_o	450 mH / 570 μ F
IIC (simple circuit): Max. external inductivity L_o / Max. external capacitance C_o	120 mH / 25 μ F
I (simple circuit): Max. external inductivity L_o / Max. external capacitance C_o	1000 mH / 1000 μ F
IIB/IIIC (mixed circuit): Max. external inductivity L_o / Max. external capacitance C_o	100 mH / 5.3 μ F, 20 mH / 6.9 μ F, 2 mH / 11 μ F, 0.5 mH / 15 μ F
IIC (mixed circuit): Max. external inductivity L_o / Max. external capacitance C_o	50 mH / 1.1 μ F, 5 mH / 1.7 μ F, 1 mH / 2.3 μ F, 0.2 mH / 3.4 μ F

Signaling

Status display	Green LED (supply voltage)
	Red LED (line errors)

Dimensions

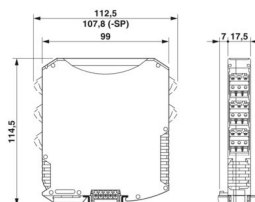
Dimensional drawing	
Width	17.5 mm
Height	112.5 mm
Depth	113.7 mm
Depth NS 35/7,5	114.5 mm (Snapped onto DIN rail NS 35/7,5 in accordance with EN 60715)

Material specifications

MACX MCR-EX-AP-RTD-RTD - Temperature measuring transducer



1291894

<https://www.phoenixcontact.com/us/products/1291894>

Flammability rating according to UL 94	V0
Housing material	PA 6.6

Environmental and real-life conditions

Ambient conditions

Degree of protection	IP20 (Terminal blocks)
	IP30 (Housing)
Ambient temperature (operation)	-20 °C ... 70 °C (Stand-alone device: any mounting position)
	-20 °C ... 60 °C (Group assembly: vertical DIN rail without circulating air)
	-20 °C ... 65 °C (Group assembly: vertical DIN rail with circulating air)
	-20 °C ... 65 °C (Group assembly: horizontal DIN rail without circulating air)
	-20 °C ... 70 °C (Group assembly: horizontal DIN rail with circulating air)
Ambient temperature (storage/transport)	-40 °C ... 80 °C
Altitude	≤ 2000 m
Permissible humidity (operation)	≤ 95 % (non-condensing)

Approvals

ATEX

Identification	⊕ II (1) G [Ex ia Ga] IIC
	⊕ II (1) D [Ex ia Da] IIIC
	⊕ II 3 (1) G Ex nA nC [ia Ga] IIC T4 Gc
	⊕ I (M1) [Ex ia Ma] I

IECEX

Identification	[Ex ia Ga] IIC
	[Ex ia Da] IIIC
	Ex nA nC [ia Ga] IIC T4 Gc
	[Ex ia Ma] I

EMC data

Electromagnetic compatibility	Tested in accordance with the following standards and regulations: EN 61326-1 For industrial use, NAMUR NE 21
-------------------------------	---

Standards and regulations

Electrical isolation	3-way isolation
----------------------	-----------------

Mounting

Mounting type	NS 35/15, NS 35/7,5
Mounting position	vertical, horizontal

MACX MCR-EX-AP-RTD-RTD - Temperature measuring transducer

1291894

<https://www.phoenixcontact.com/us/products/1291894>

Drawings

Dimensional drawing

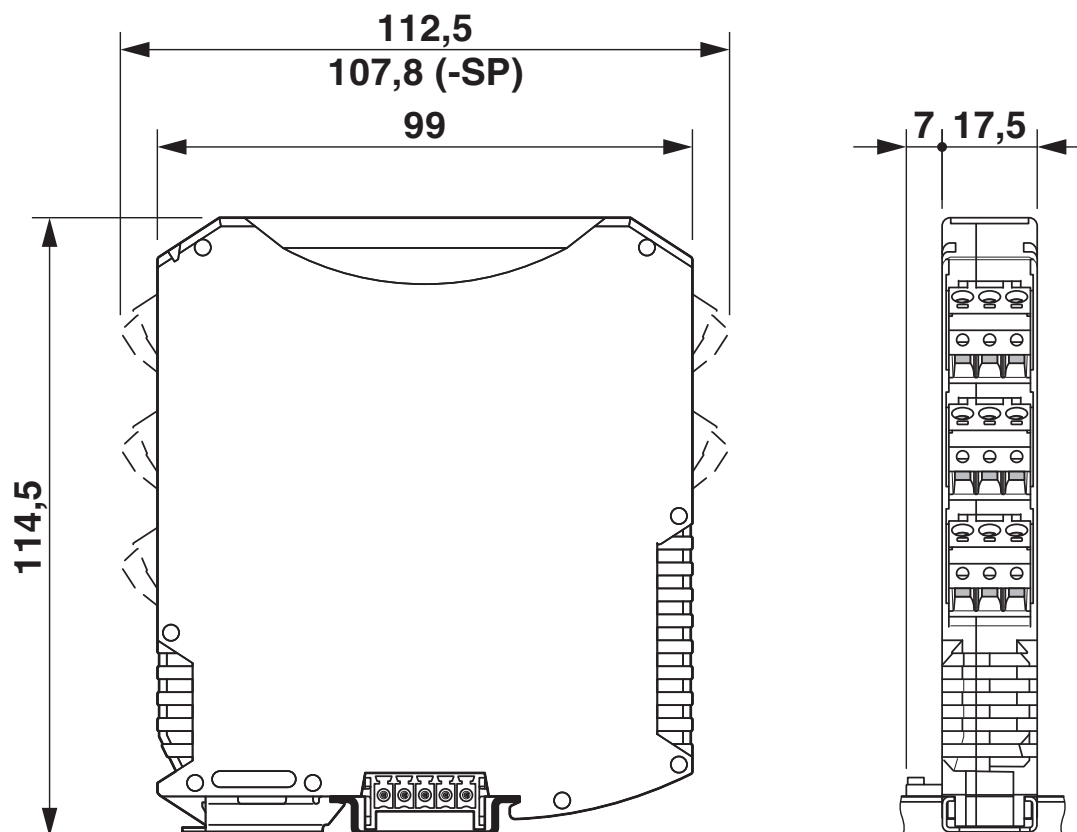

MACX MCR-EX-AP-RTD-RTD - Temperature measuring transducer

1291894

<https://www.phoenixcontact.com/us/products/1291894>

Block diagram

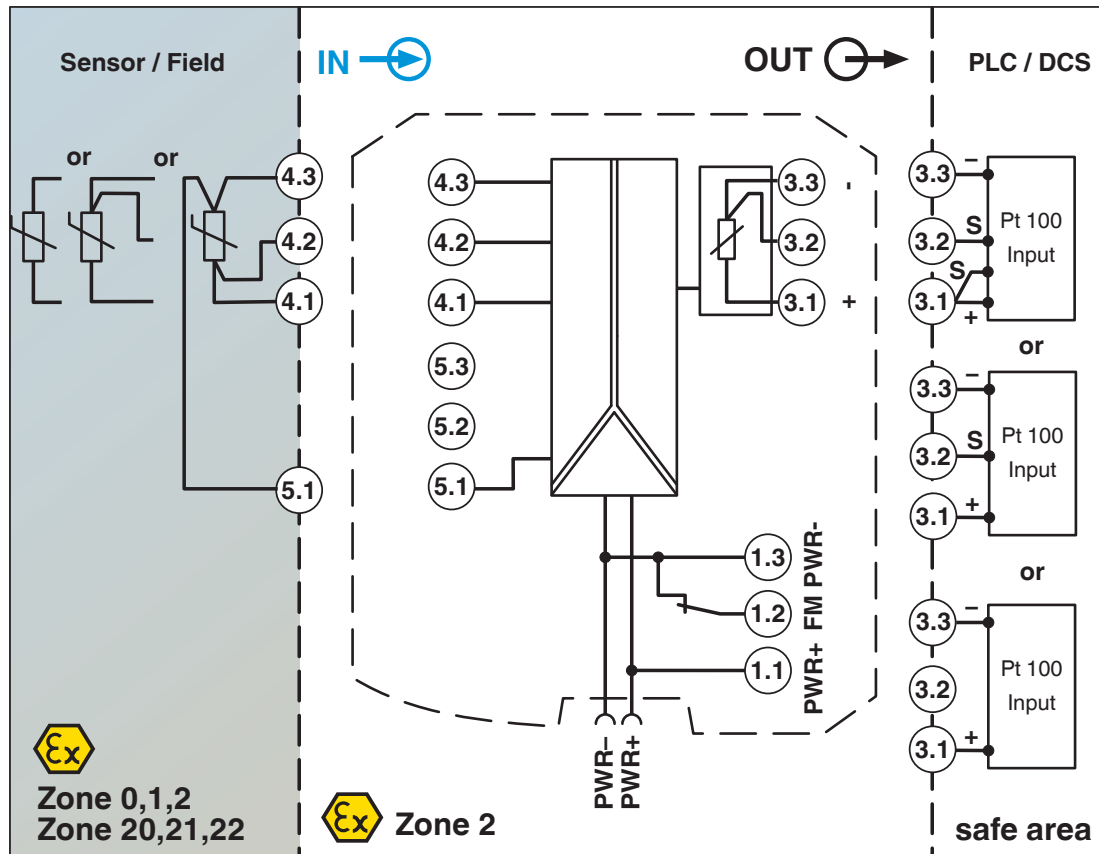

MACX MCR-EX-AP-RTD-RTD - Temperature measuring transducer



1291894

<https://www.phoenixcontact.com/us/products/1291894>

Approvals

To download certificates, visit the product detail page: <https://www.phoenixcontact.com/us/products/1291894>



IECEX

Approval ID: IECEX BVS 21.0033X



ATEX

Approval ID: BVS 21 ATEX E 031X

MACX MCR-EX-AP-RTD-RTD - Temperature measuring transducer



1291894

<https://www.phoenixcontact.com/us/products/1291894>

Classifications

ECLASS

ECLASS-13.0	27210129
ECLASS-15.0	27210129

ETIM

ETIM 10.0	EC002919
-----------	----------

MACX MCR-EX-AP-RTD-RTD - Temperature measuring transducer



1291894

<https://www.phoenixcontact.com/us/products/1291894>

Environmental product compliance

EU RoHS

Fulfills EU RoHS substance requirements	Yes
Exemption	6(c), 7(a), 7(c)-I

China RoHS

Environment friendly use period (EFUP)	EFUP-50
	An article-related China RoHS declaration table can be found in the download area for the respective article under "Manufacturer declaration". For all articles with EFUP-E, no China RoHS declaration table issued and required.

EU REACH SVHC

REACH candidate substance (CAS No.)	Lead titanium zirconium oxide(CAS: 12626-81-2)
	Lead(CAS: 7439-92-1)
SCIP	94c59bd9-d5b5-4802-8972-47743bc10e55

Phoenix Contact 2026 © - all rights reserved

<https://www.phoenixcontact.com>

Phoenix Contact USA
586 Fulling Mill Road
Middletown, PA 17057, United States
(+717) 944-1300
info@phoenixcon.com