

RC-0000000Q0FZX - Rear panel feed-through



1240297

<https://www.phoenixcontact.com/us/products/1240297>

Please be informed that the data shown in this PDF document is generated from our online catalog. Please find the complete data in the user documentation. Our general terms of use for downloads are valid.



Rear panel feed-through, series: RC, straight, Axial O-ring, Central fixing, shielded: yes, Item is lead-free in accordance with RoHS II without Exemption 6c (Pb < 0.1 %)

Commercial data

Item number	1240297
Packing unit	12 pc
Minimum order quantity	12 pc
Product key	ABRAFK
GTIN	4063151430061
Weight per piece (including packing)	95.6 g
Weight per piece (excluding packing)	86.02 g
Country of origin	DE

RC-0000000Q0FZX - Rear panel feed-through



1240297

<https://www.phoenixcontact.com/us/products/1240297>

Technical data

Product properties

Product type	Circular connector housing
Series	RC
Application	Signal
Shielded	yes

Connector

Type	straight
------	----------

Environmental and real-life conditions

Ambient conditions

Degree of protection	IP67
Ambient temperature (operation)	-20 °C ... 125 °C
Altitude	2000 m

Mounting

Mounting	Central fixing
----------	----------------

RC-0000000Q0FZX - Rear panel feed-through



1240297

<https://www.phoenixcontact.com/us/products/1240297>

Drawings

Dimensional drawing

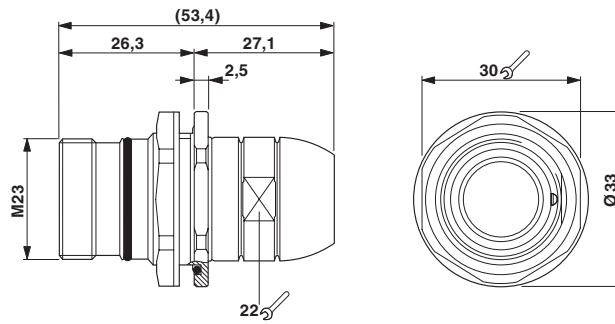

Dimensional drawing

Dimensional drawing

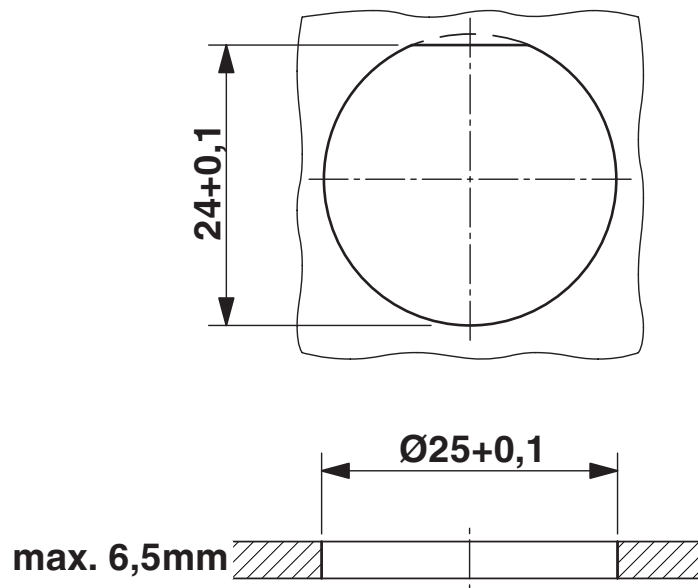

Installation dimensions

RC-0000000Q0FZX - Rear panel feed-through



1240297

<https://www.phoenixcontact.com/us/products/1240297>

Classifications

ECLASS

ECLASS-13.0

27440224

ETIM

ETIM 9.0

EC003556

RC-0000000Q0FZX - Rear panel feed-through



1240297

<https://www.phoenixcontact.com/us/products/1240297>

Environmental product compliance

EU RoHS

Fulfills EU RoHS substance requirements	Yes, No exemptions
---	--------------------

China RoHS

Environment friendly use period (EFUP)	EFUP-E
	No hazardous substances above the limits

EU REACH SVHC

REACH candidate substance (CAS No.)	No substance above 0.1 wt%
-------------------------------------	----------------------------

Phoenix Contact 2026 © - all rights reserved
<https://www.phoenixcontact.com>

Phoenix Contact USA
586 Fulling Mill Road
Middletown, PA 17057, United States
(+717) 944-1300
info@phoenixcon.com