

PSR-ESS-ACC-CB1-SM-SC - Contact module



1221749

<https://www.phoenixcontact.com/us/products/1221749>

Please be informed that the data shown in this PDF document is generated from our online catalog. Please find the complete data in the user documentation. Our general terms of use for downloads are valid.



Contact module for modular emergency stop switches with force-guided N/C contact for safety-related shutdown, N/O contact for assembly monitoring, in conjunction with appropriate evaluation unit suitable for use up to PL e (EN ISO 13849-1), SIL 3 (EN IEC 62061)

Product description

Phoenix Contact emergency stop switches are electromechanical switching devices with a safety function. They are used to safely shut down or stop machines and systems in order to prevent or minimize personal injury and property damage. The portfolio includes a modular system as well as a preconfigured solution. The modular emergency stop switch is comprised of the following components: - PSR-ESS-M0-H100 /...110 / ...120 actuator - PSR-ESS-ACC-CB1-C... module holder - PSR-ESS-ACC-CB1-NC-SC or PSR-ESS-ACC-CB1-SM-SC safe contact module Further contact modules can be combined if required.

Your advantages

- Modular system allows an efficient solution for individual applications
- Direct opening action in accordance with IEC 60947-5-1
- In applications with appropriate evaluation device suitable for use up to PL e (EN ISO 13849-1), SIL 3 (EN IEC 62061)
- Protection against installation errors with self-monitoring via the contact module

Commercial data

Item number	1221749
Packing unit	1 pc
Minimum order quantity	1 pc
Sales key	DN04
Product key	DNA62Z
GTIN	4063151309961
Weight per piece (including packing)	30.3 g
Weight per piece (excluding packing)	30.3 g
Customs tariff number	85365080
Country of origin	DE

1221749

<https://www.phoenixcontact.com/us/products/1221749>

Technical data

Notes

Note on application

Note on application	Only for industrial use
---------------------	-------------------------

Product properties

Product type	Contact module
Product family	Modular emergency stop switches
Application	Safe shutdown + assembly monitoring
Recommended backup fuse	16 A (SCPD Car. C)

Insulation characteristics

Overvoltage category	III
Protection class	II
Pollution degree	3

Electrical properties

Short-circuit current	1000 A (conditional short-circuit current I_q)
Rated surge voltage	2.5 kV

Contact information

Contact switching type	1 force-guided N/C contact + 1 N/O contact
Contact material	AgNi
Positive opening action	in accordance with EN 60947-5-1, Annex K
Actuating travel	6 mm
Voltage	min. 5 V
	max. (see load limit current)
Current	min. 1 mA
	max. (see load limit current)
Electrical service life	10^6 switching cycles
Mechanical service life	20,000 switching cycles
Contact resistance	< 100 mΩ
Bouncing time	< 10 ms

Load limit current in accordance with IEC/EN 60947-5-1

Standard	IEC/EN 60947-5-1
Utilization category	AC15
Rated insulation voltage U_i	250 V
Rated operating voltage U_e	240 V
Rated operating current I_e (AC-15, 230 V)	3 A
Switching capacity	$10 \times I_e$
Thermal continuous current I_{th}	16 A
Utilization category	DC13

PSR-ESS-ACC-CB1-SM-SC - Contact module



1221749

<https://www.phoenixcontact.com/us/products/1221749>

Rated insulation voltage U_i	250 V
Rated operating voltage U_e	250 V
	125 V
	60 V
	24 V
Rated operating current I_e	0.2 A
	0.4 A
	1 A
	2 A
Switching capacity	1.1x I_e

Connection data

Conductor connection

Connection method	Screw connection
Note regarding the connection technology	2 conductors possible per terminal point, with one conductor on each side of the screw
Conductor cross-section rigid	0.5 mm ² ... 2.5 mm ²
Conductor cross-section flexible	0.5 mm ² ... 2.5 mm ²
Flexible conductor cross-section with ferrule	0.25 mm ² ... 2.5 mm ²
Conductor cross-section AWG	20 ... 14 (rigid and flexible conductors without ferrules)
	23 ... 14 (flexible conductors with ferrules)
Stripping length	8 mm ... 9 mm
Tightening torque	0.8 Nm ... 1 Nm

Dimensions

Dimensional drawing	
Width	9.1 mm
Height	34.8 mm
Depth	44.6 mm

Material specifications

Color (Upper housing part)	red (RAL 3001)
Color (Lower housing part)	brown (RAL 8028)
Flammability rating according to UL 94	V0
Housing material	PA

Environmental and real-life conditions

Ambient conditions

Degree of protection	IP20
----------------------	------

PSR-ESS-ACC-CB1-SM-SC - Contact module



1221749

<https://www.phoenixcontact.com/us/products/1221749>

Ambient temperature (operation)	-30 °C ... 85 °C (in conjunction with lighting module max. 65°C)
Ambient temperature (storage/transport)	-50 °C ... 85 °C
Maximum altitude	max. 2000 m (Above sea level)
Shock	15g / 11 ms, in accordance with IEC 60068-2-27
Vibration (operation)	10 Hz ... 500 Hz, 0.35 mm amplitude, 5g, in accordance with IEC 60068-2-6

Mounting

Mounting type	Plug-in mounting
Mounting position	any

PSR-ESS-ACC-CB1-SM-SC - Contact module



1221749

<https://www.phoenixcontact.com/us/products/1221749>

Drawings

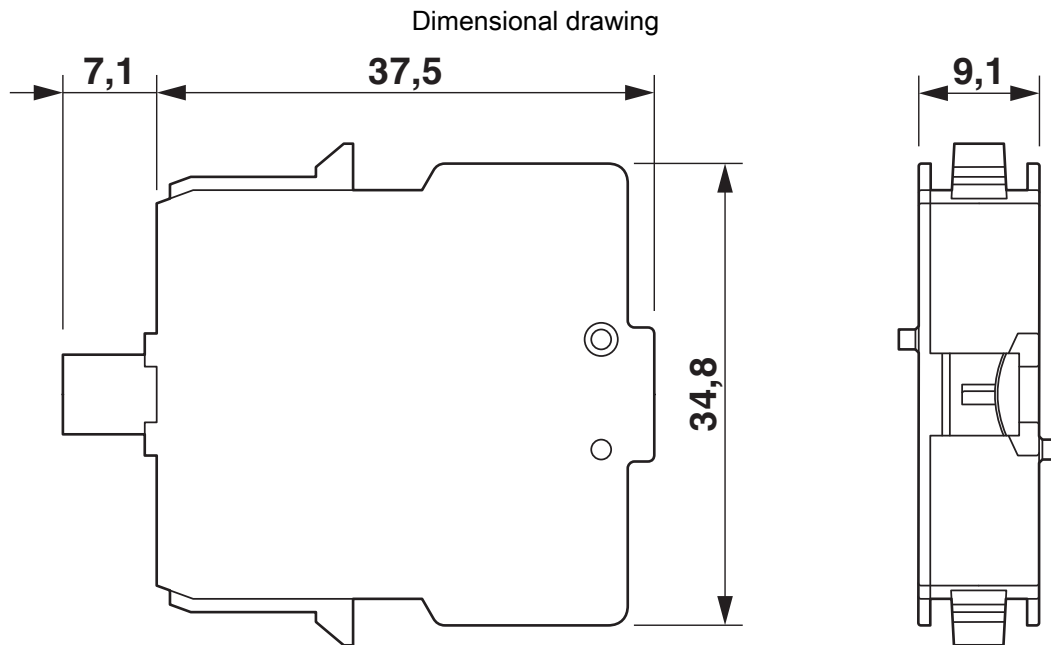

Dimensions (in mm)

1221749

<https://www.phoenixcontact.com/us/products/1221749>

Approvals

To download certificates, visit the product detail page: <https://www.phoenixcontact.com/us/products/1221749>



UL Listed

Approval ID: E140324



cUL Listed

Approval ID: E140324



Functional Safety

Approval ID: B 029429 0031 Rev01



EAC

Approval ID: RU*DE*B*00073/21

PSR-ESS-ACC-CB1-SM-SC - Contact module



1221749

<https://www.phoenixcontact.com/us/products/1221749>

Classifications

ECLASS

ECLASS-13.0	27371302
ECLASS-15.0 ASSET	27250101
ECLASS-15.0	27371302

ETIM

ETIM 10.0	EC000041
-----------	----------

UNSPSC

UNSPSC 21.0	39122200
-------------	----------

1221749

<https://www.phoenixcontact.com/us/products/1221749>

Environmental product compliance

EU RoHS

Fulfills EU RoHS substance requirements	Yes, No exemptions
---	--------------------

China RoHS

Environment friendly use period (EFUP)	EFUP-E
	No hazardous substances above the limits

EU REACH SVHC

REACH candidate substance (CAS No.)	No substance above 0.1 wt%
-------------------------------------	----------------------------

EF3.1 Climate Change

CO2e kg	1.149 kg CO2e
---------	---------------

Phoenix Contact 2026 © - all rights reserved
<https://www.phoenixcontact.com>

Phoenix Contact USA
586 Fulling Mill Road
Middletown, PA 17057, United States
(+717) 944-1300
info@phoenixcon.com