

1221737

<https://www.phoenixcontact.com/us/products/1221737>

Please be informed that the data shown in this PDF document is generated from our online catalog. Please find the complete data in the user documentation. Our general terms of use for downloads are valid.



Emergency stop switch, in conjunction with appropriate evaluation unit suitable for use up to PL e (EN ISO 13849-1), SIL 3 (EN IEC 62061), panel installation, 5-pos. M12 connection

Product description

Phoenix Contact emergency stop switches are electromechanical switching devices with a safety function. They are used to safely shut down or stop machines and systems in order to prevent or minimize personal injury and property damage. The portfolio includes a modular system as well as a preconfigured solution. The preconfigured emergency stop switch is ready for immediate use and is connected via a 5-position M12 male connector. Thanks to its compact design, the emergency stop switch can be used flexibly and can be installed in a wide range of control points.

Your advantages

- Flexible use, thanks to compact design
- Protection on both sides against environmental influences with IP65/IP67 degree of protection
- Reduction of wiring errors with uniform 5-position M12 connection
- Rapid on-site diagnostics with color-coded switching position indicator
- In applications with appropriate evaluation device suitable for use up to PL e (EN ISO 13849-1), SIL 3 (EN IEC 62061)

Commercial data

Item number	1221737
Packing unit	1 pc
Minimum order quantity	1 pc
Sales key	DN04
Product key	DNA621
GTIN	4063151311025
Weight per piece (including packing)	53 g
Weight per piece (excluding packing)	47.2 g
Customs tariff number	85365080
Country of origin	DE

PSR-ESS-M0-H210-2000-A - Emergency stop switch



1221737

<https://www.phoenixcontact.com/us/products/1221737>

Technical data

Notes

Note on application

Note on application	Only for industrial use
---------------------	-------------------------

Product properties

Product type	Emergency stop switch
--------------	-----------------------

Insulation characteristics

Overvoltage category	II
Pollution degree	2

Electrical properties

Rated surge voltage	0.5 kV
---------------------	--------

Contact information

Contact switching type	2 force-guided N/C contacts
Contact material	AgNi
Positive opening action	in accordance with EN 60947-5-1, Annex K
Voltage	max. (see load limit current)
Current	max. (see load limit current)
Electrical service life	50,000 switching cycles
Mechanical service life	50,000 switching cycles
Bouncing time	< 10 ms

Load limit current in accordance with IEC/EN 60947-5-1

Standard	IEC/EN 60947-5-1
Utilization category	AC15
Rated insulation voltage U_i	250 V
Rated operating voltage U_e	35 V
Rated operating current I_e	2 A
Switching capacity	10x I_e
Utilization category	DC13
Rated insulation voltage U_i	250 V
Rated operating voltage U_e	35 V
Rated operating current I_e	2 A
Switching capacity	1.1x I_e

Connection data

Connection method	M12 connector, A-coded
-------------------	------------------------

Dimensions

PSR-ESS-M0-H210-2000-A - Emergency stop switch



1221737

<https://www.phoenixcontact.com/us/products/1221737>

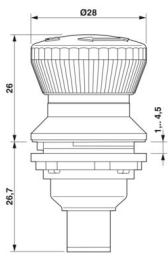
Dimensional drawing	
Depth	52.7 mm
Diameter	28 mm

Material specifications

Color (Mushroom head button)	red (RAL 3001)
Color (Front frame)	yellow (RAL 1018)
Flammability rating according to UL 94	V2 (Actuator)
	V0 (Contact element)
	V0 (M12 plug)
	min. HB (Molding compound)
Housing material	PA

Environmental and real-life conditions

Ambient conditions

Degree of protection	IP65/IP67 (with professional installation in the appropriate installation space)
Ambient temperature (operation)	-25 °C ... 70 °C
Ambient temperature (storage/transport)	-40 °C ... 80 °C
Maximum altitude	max. 2000 m (Above sea level)
Shock	15g / 11 ms, in accordance with IEC 60068-2-27
Vibration (operation)	10 Hz ... 500 Hz, 0.35 mm amplitude, 5g, in accordance with IEC 60068-2-6

Mounting

Mounting type	Panel mount
Assembly note	Mounting nut torque: 1.0 Nm ... 1.7 Nm
Mounting position	any

PSR-ESS-M0-H210-2000-A - Emergency stop switch



1221737

<https://www.phoenixcontact.com/us/products/1221737>

Drawings

Dimensional drawing

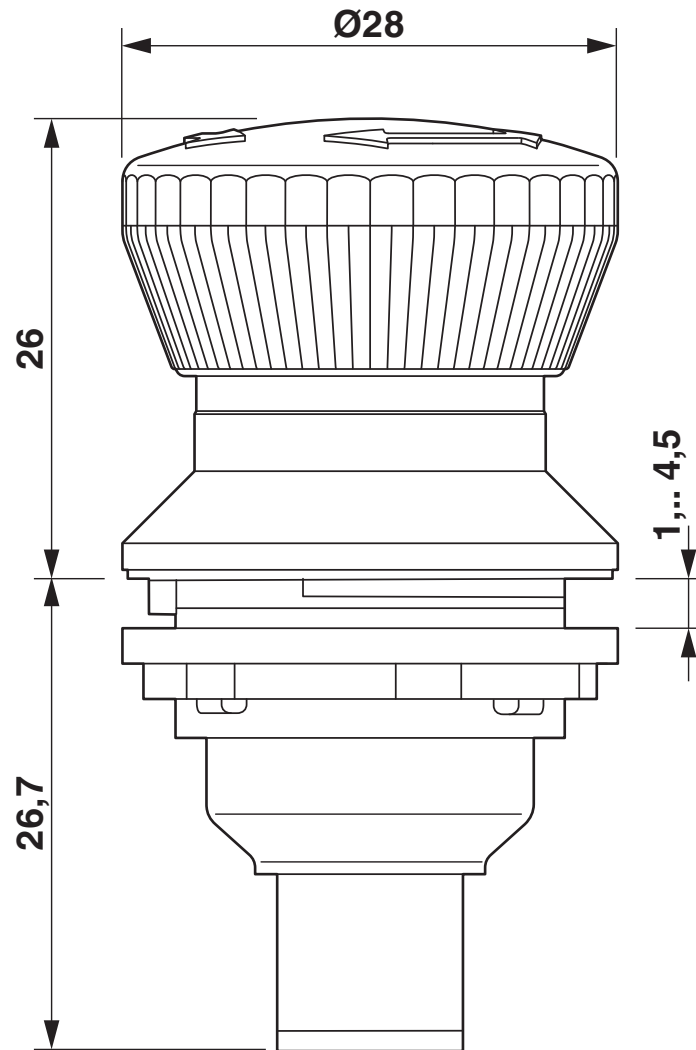

Dimensions (in mm)

PSR-ESS-M0-H210-2000-A - Emergency stop switch



1221737

<https://www.phoenixcontact.com/us/products/1221737>

Approvals

To download certificates, visit the product detail page: <https://www.phoenixcontact.com/us/products/1221737>



cUL Recognized
Approval ID: E519465



UL Recognized
Approval ID: E519465



EAC
Approval ID: RU*DE*B*00073/21



Functional Safety
Approval ID: B 029429 0031 Rev01

PSR-ESS-M0-H210-2000-A - Emergency stop switch



1221737

<https://www.phoenixcontact.com/us/products/1221737>

Classifications

ECLASS

ECLASS-13.0	27371216
ECLASS-15.0	27371216
ECLASS-15.0 ASSET	27250101

ETIM

ETIM 10.0	EC000225
-----------	----------

UNSPSC

UNSPSC 21.0	39122200
-------------	----------

1221737

<https://www.phoenixcontact.com/us/products/1221737>

Environmental product compliance

EU RoHS

Fulfills EU RoHS substance requirements	Yes
Exemption	6(c)

China RoHS

Environment friendly use period (EFUP)	EFUP-25
	An article-related China RoHS declaration table can be found in the download area for the respective article under "Manufacturer declaration". For all articles with EFUP-E, no China RoHS declaration table issued and required.

EU REACH SVHC

REACH candidate substance (CAS No.)	Lead(CAS: 7439-92-1)
SCIP	0981dc4f-5b5e-41ee-828f-49f22ef6ec41

EF3.1 Climate Change

CO2e kg	4.584 kg CO2e
---------	---------------

Phoenix Contact 2026 © - all rights reserved
<https://www.phoenixcontact.com>

Phoenix Contact USA
586 Fulling Mill Road
Middletown, PA 17057, United States
(+717) 944-1300
info@phoenixcon.com