

# SF-ASD 16/ACCU 1,5 AH - Battery module



1200297

<https://www.phoenixcontact.com/us/products/1200297>

Please be informed that the data shown in this PDF document is generated from our online catalog. Please find the complete data in the user documentation. Our general terms of use for downloads are valid.

Replacement battery, 1.5 Ah, lithium-ion, 3.6 V, for SF-ASD 16 cordless screwdriver



## Your advantages

- Reverse polarity protected
- 3.6 V
- 1.5 Ah

## Commercial data

Item number	1200297
Packing unit	1 pc
Note	Made to order (non-returnable)
Sales key	BH32
Product key	BH324Y
GTIN	4055626666457
Weight per piece (including packing)	95 g
Weight per piece (excluding packing)	85 g
Customs tariff number	85076000
Country of origin	TW

# SF-ASD 16/ACCU 1,5 AH - Battery module



1200297

<https://www.phoenixcontact.com/us/products/1200297>

## Technical data

### Product properties

Product type	Battery module
Type of packaging	packed in cardboard
Battery-operated voltage	3.6 V
Battery charging	60 min

### Electrical properties

Power consumption	5.4 W
Nominal voltage $U_N$	3.6 V DC
	3.6 V DC

### Battery

Battery charging	60.00 min
Battery-operated voltage	3.60 V DC
Battery capacity	1.50 Ah

### Dimensions

Length	82 mm
Diameter	43 mm

### Environmental and real-life conditions

#### Ambient conditions

Ambient temperature (operation)	5 °C ... 40 °C
Ambient temperature (storage/transport)	-25 °C ... 60 °C
Permissible humidity (operation)	95 % (<)

Drawings

Schematic diagram

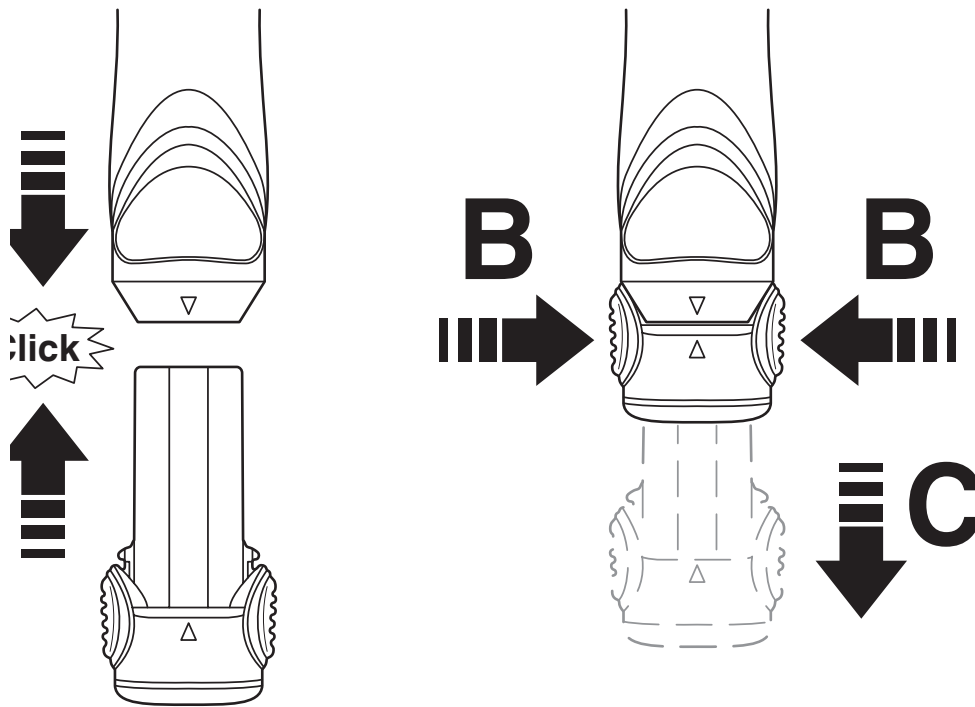

Schematic diagram

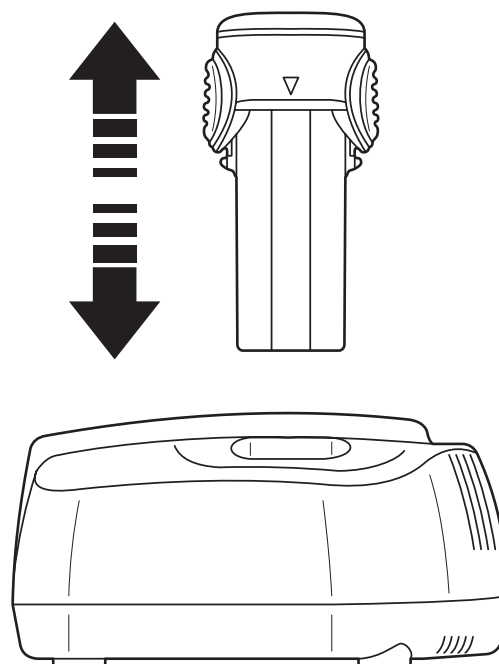

# SF-ASD 16/ACCU 1,5 AH - Battery module



1200297

<https://www.phoenixcontact.com/us/products/1200297>

## Approvals

To download certificates, visit the product detail page: <https://www.phoenixcontact.com/us/products/1200297>



**EAC**

Approval ID: RU C-DE.AI30.B.01750

# SF-ASD 16/ACCU 1,5 AH - Battery module



1200297

<https://www.phoenixcontact.com/us/products/1200297>

## Classifications

### UNSPSC

UNSPSC 21.0	26111700
-------------	----------

# SF-ASD 16/ACCU 1,5 AH - Battery module



1200297

<https://www.phoenixcontact.com/us/products/1200297>

## Environmental product compliance

### EU RoHS

Fulfills EU RoHS substance requirements	Not applicable, No electrical and electronic equipment (EEE), cannot be used in EEE
---	---

### China RoHS

Environment friendly use period (EFUP)	EFUP-5
	An article-related China RoHS declaration table can be found in the download area for the respective article under "Manufacturer declaration". For all articles with EFUP-E, no China RoHS declaration table issued and required.

### EU REACH SVHC

REACH candidate substance (CAS No.)	No substance above 0.1 wt%
-------------------------------------	----------------------------

Phoenix Contact 2026 © - all rights reserved  
<https://www.phoenixcontact.com>

Phoenix Contact USA  
586 Fulling Mill Road  
Middletown, PA 17057, United States  
(+717) 944-1300  
[info@phoenixcon.com](mailto:info@phoenixcon.com)