

# SF-ASD 16 - Cordless screwdriver



1200294

<https://www.phoenixcontact.com/us/products/1200294>

Please be informed that the data shown in this PDF document is generated from our online catalog. Please find the complete data in the user documentation. Our general terms of use for downloads are valid.



Cordless screwdriver, incl. battery, two-speed gearbox, forward/reverse running and 16-stage clutch up to 450 rpm, hexagonal quick connection.

## Your advantages

- Cordless screwdriver with two-speed gearbox, forward/reverse running and 16-stage clutch with drilling stage of up to 450 rpm
- Adjustable from 0.2 ... 4.3 Nm
- Comfortable one-handed operation in a straight or angled position
- Compact design

## Commercial data

Item number	1200294
Packing unit	1 pc
Minimum order quantity	1 pc
Sales key	BH32
Product key	BH3243
GTIN	4055626666426
Weight per piece (including packing)	565 g
Weight per piece (excluding packing)	465 g
Customs tariff number	84672920
Country of origin	TW

# SF-ASD 16 - Cordless screwdriver



1200294

<https://www.phoenixcontact.com/us/products/1200294>

## Technical data

### Notes

#### Environmental Product Compliance

California Proposition 65	Further information on California's prop. 65 is available under "Downloads" in the manufacturer's declaration
---------------------------	---

### Product properties

Product type	Torque tool
Type of packaging	packed in cardboard
Battery-operated voltage	3.6 V
Battery charging	60 min
Product property	Cordless screwdriver with two-speed gear and forward/reverse running 16-stage clutch with drilling setting up to 450 rpm

#### Insulation characteristics

Protection class	II
------------------	----

### Electrical properties

Power consumption	7.2 W
Nominal voltage $U_N$	3.6 V DC 3.6 V DC

#### Battery

Battery charging	60.00 min
Battery-operated voltage	3.60 V DC
Battery capacity	2.00 Ah

### Connection data

Torque range	0.2 Nm ... 4.3 Nm
Output	6,3 mm

### Dimensions

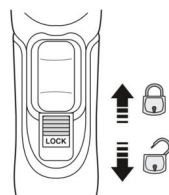
Dimensional drawing	
Width	45 mm
Height	172 mm
Length	266 mm

# SF-ASD 16 - Cordless screwdriver



1200294

<https://www.phoenixcontact.com/us/products/1200294>

## Environmental and real-life conditions

### Ambient conditions

Ambient temperature (operation)	5 °C ... 40 °C
Ambient temperature (storage/transport)	-25 °C ... 60 °C
Permissible humidity (operation)	95 % (<)

# SF-ASD 16 - Cordless screwdriver

1200294

<https://www.phoenixcontact.com/us/products/1200294>



## Drawings

Dimensional drawing

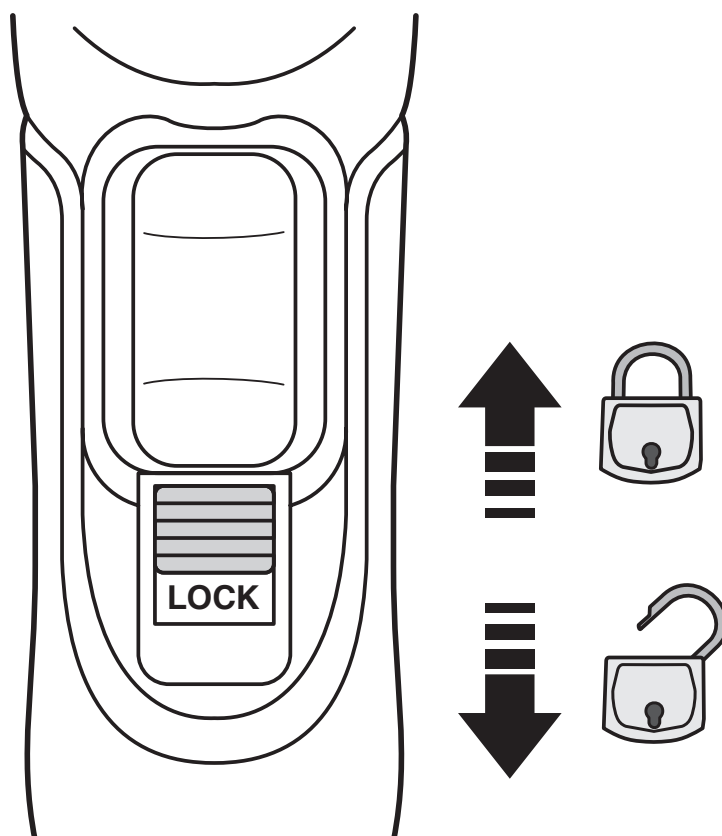

# SF-ASD 16 - Cordless screwdriver

1200294

<https://www.phoenixcontact.com/us/products/1200294>



Schematic diagram

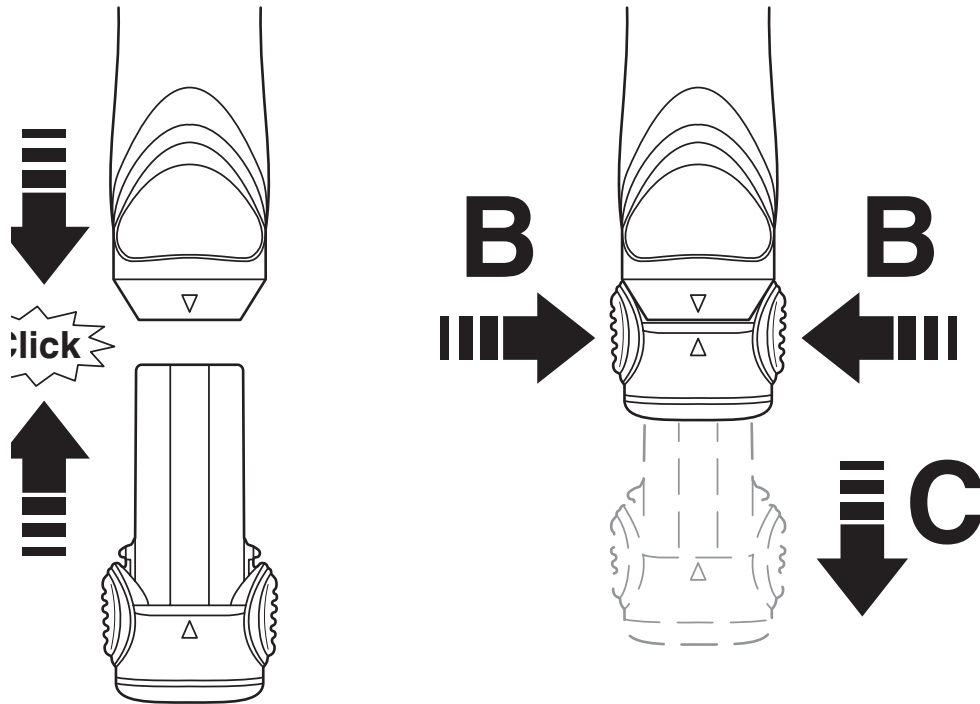

Schematic diagram

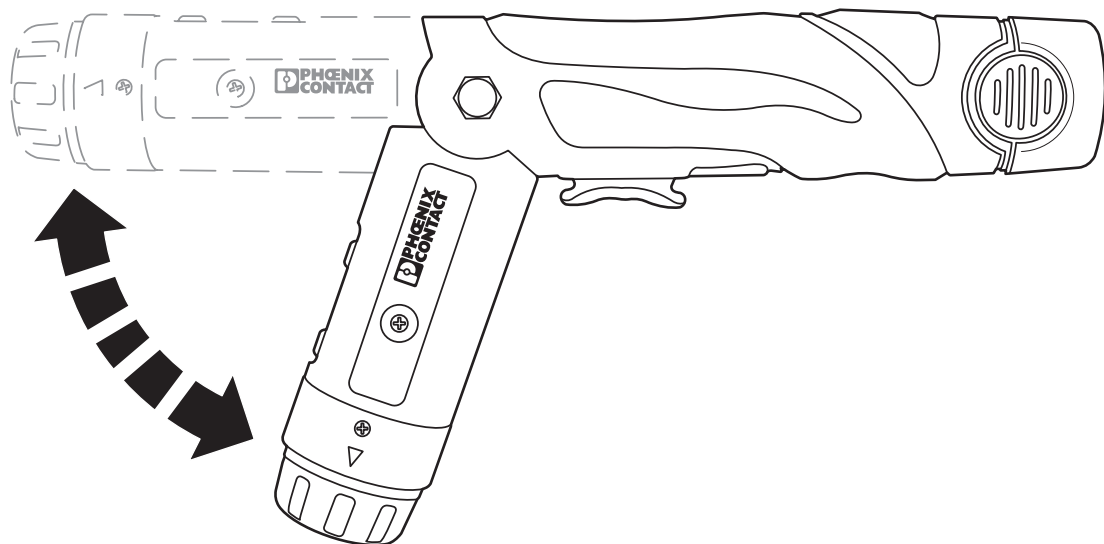

# SF-ASD 16 - Cordless screwdriver

1200294

<https://www.phoenixcontact.com/us/products/1200294>



Schematic diagram

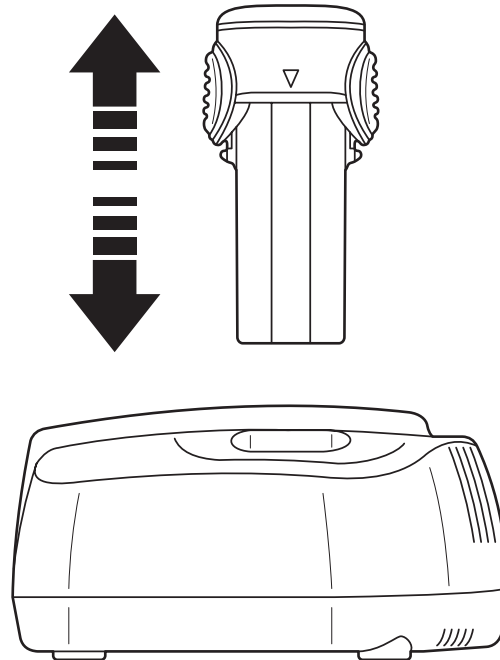

Schematic diagram

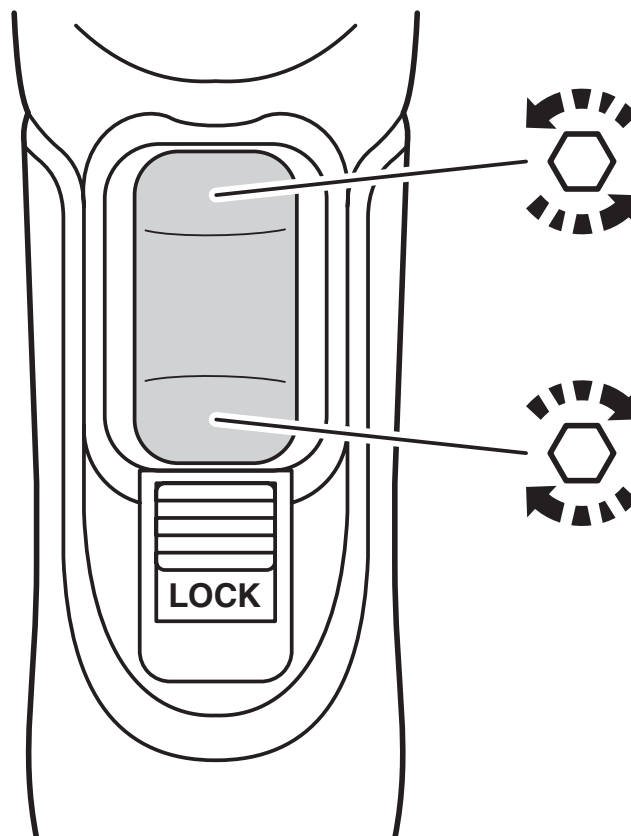

# SF-ASD 16 - Cordless screwdriver



1200294

<https://www.phoenixcontact.com/us/products/1200294>

## Classifications

### ECLASS

ECLASS-13.0	21050804
ECLASS-15.0	21050804

### ETIM

ETIM 10.0	EC001396
-----------	----------

### UNSPSC

UNSPSC 21.0	27111700
-------------	----------

# SF-ASD 16 - Cordless screwdriver



1200294

<https://www.phoenixcontact.com/us/products/1200294>

## Environmental product compliance

### EU RoHS

Fulfills EU RoHS substance requirements	Yes, No exemptions
---	--------------------

### China RoHS

Environment friendly use period (EFUP)	EFUP-5
	An article-related China RoHS declaration table can be found in the download area for the respective article under "Manufacturer declaration". For all articles with EFUP-E, no China RoHS declaration table issued and required.

### EU REACH SVHC

REACH candidate substance (CAS No.)	No substance above 0.1 wt%
-------------------------------------	----------------------------

Phoenix Contact 2026 © - all rights reserved  
<https://www.phoenixcontact.com>

Phoenix Contact USA  
586 Fulling Mill Road  
Middletown, PA 17057, United States  
(+717) 944-1300  
[info@phoenixcon.com](mailto:info@phoenixcon.com)