

HC-M-B16-MFH-B - Module carrier frame



1182090

<https://www.phoenixcontact.com/us/products/1182090>

Please be informed that the data shown in this PDF document is generated from our online catalog. Please find the complete data in the user documentation. Our general terms of use for downloads are valid.

Module carrier frame, size: B16, type : for the panel mounting side (a, b, c, ...), 4 mm² ... 6 mm², application: Module carrier frame



Commercial data

Item number	1182090
Packing unit	1 pc
Minimum order quantity	1 pc
Sales key	BF62
Product key	AF7ACD
GTIN	4063151218652
Weight per piece (including packing)	85.3 g
Weight per piece (excluding packing)	82.2 g
Customs tariff number	85389099
Country of origin	CN

HC-M-B16-MFH-B - Module carrier frame



1182090

<https://www.phoenixcontact.com/us/products/1182090>

Technical data

Notes

General	This product replaces 1417400 HC-M-B16-MF-B
---------	---

Product properties

Product type	Module carrier frame
Series	HC-M-B
	HC-M-02
	HC-M-03
	HC-M-03/04
	HC-M-04
	HC-M-05
	HC-M-06
	HC-M-08
	HC-M-08-GBIT
	HC-M-12
	HC-M-17
	HC-M-20
	HC-M-25
	HC-M-DSUB
	HC-M-EMV
	HC-M-HV
HC-M-HS	
HC-M-00	
Application	Module carrier frame
Type	B16
	B32
Number of module slots	4
Frame type	Module carrier frame

Connection data

Conductor connection

Conductor cross-section	4 mm ² ... 6 mm ² (for PE conductor - power side)
	1 mm ² ... 2.5 mm ² (for PE conductor control side)
Connection cross section AWG	12 ... 10 (for PE conductor - power side)
	18 ... 14 (for PE conductor control side)
Tightening torque	0.5 Nm ... 0.8 Nm (Mounting screws for mounting in the HEAVYCON housing)

Dimensions

HC-M-B16-MFH-B - Module carrier frame



1182090

<https://www.phoenixcontact.com/us/products/1182090>

Dimensional drawing	
Width	34.9 mm
Height	36 mm
Length	84.5 mm

Material specifications

Contact carrier material	Die-cast zinc alloy
--------------------------	---------------------

Mechanical properties

Mechanical data

Insertion/withdrawal cycles	≥ 500
-----------------------------	-------

Environmental and real-life conditions

Ambient conditions

Ambient temperature (operation)	-40 °C ... 125 °C
---------------------------------	-------------------

Mounting

Assembly note	<p>HC-MHR-PE16 (1636981) for PE connection extension to 16 mm².</p> <p>Use wire end protection for PE wires (PE connection screws without wire protection) for housings without lateral connectors, max. thread length of the screw connection 12 mm</p> <p>When using the module carrier frame in metal housings, the connection of the PE conductor must be ensured via the PE connection provided on the module carrier frame or via a special metal PE module</p>
---------------	---

HC-M-B16-MFH-B - Module carrier frame



1182090

<https://www.phoenixcontact.com/us/products/1182090>

Drawings

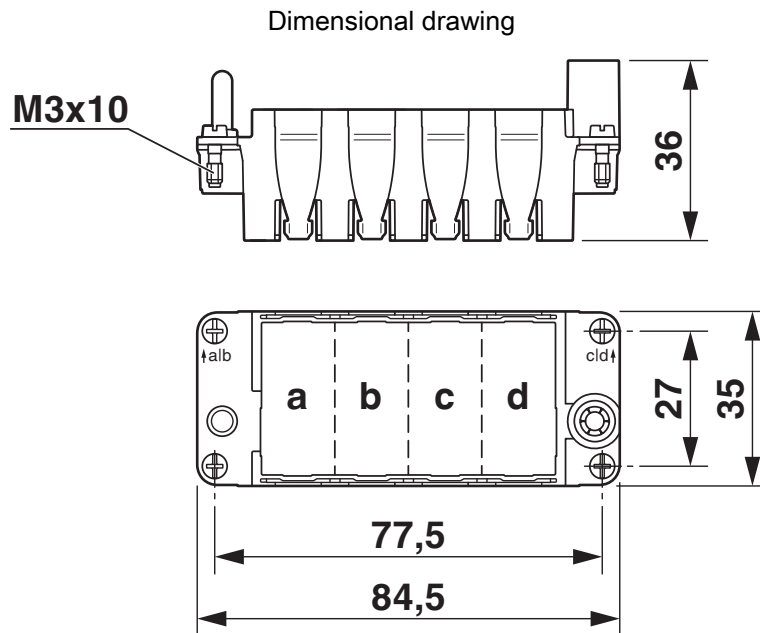

Dimensional drawing

HC-M-B16-MFH-B - Module carrier frame



1182090

<https://www.phoenixcontact.com/us/products/1182090>

Approvals

To download certificates, visit the product detail page: <https://www.phoenixcontact.com/us/products/1182090>

 **CSA**
Approval ID: 158887

 **UL Recognized**
Approval ID: E118976

 **UL Recognized**
Approval ID: E118976

HC-M-B16-MFH-B - Module carrier frame



1182090

<https://www.phoenixcontact.com/us/products/1182090>

Classifications

ECLASS

ECLASS-13.0	27440206
ECLASS-15.0	27440206

ETIM

ETIM 10.0	EC002312
-----------	----------

UNSPSC

UNSPSC 21.0	31261500
-------------	----------

1182090

<https://www.phoenixcontact.com/us/products/1182090>

Environmental product compliance

EU RoHS

Fulfills EU RoHS substance requirements	Yes
Exemption	6(c)

China RoHS

Environment friendly use period (EFUP)	EFUP-50
	An article-related China RoHS declaration table can be found in the download area for the respective article under "Manufacturer declaration". For all articles with EFUP-E, no China RoHS declaration table issued and required.

EU REACH SVHC

REACH candidate substance (CAS No.)	Lead(CAS: 7439-92-1)
SCIP	c1b4b9a7-09d8-422a-a53d-de8db0f0f039

Phoenix Contact 2026 © - all rights reserved

<https://www.phoenixcontact.com>

Phoenix Contact USA
586 Fulling Mill Road
Middletown, PA 17057, United States
(+717) 944-1300
info@phoenixcon.com