

VAL-EV-T1/T2 264/12.5/3+1 - Lightning/surge arrester type 1/2



1180149

<https://www.phoenixcontact.com/us/products/1180149>

Please be informed that the data shown in this PDF document is generated from our online catalog. Please find the complete data in the user documentation. Our general terms of use for downloads are valid.



CHARX protect advanced: Plug-in lightning surge/surge protective device, in accordance with Type 1/2 / Class I/II, for 3-phase power supply networks with separate N and PE (5-conductor system: L1, L2, L3, N, PE). Specifically designed for use in e-mobility.

Your advantages

- Uninterrupted continuation of the charging process with a protected power supply
- Additional protection for the connected electric vehicle
- High system availability, thanks to a high-performance protective circuit
- Easy insulation measurement and simple replacement during servicing with consistently pluggable protective devices
- No mismatching of plugs, thanks to mechanical coding

Commercial data

Item number	1180149
Packing unit	1 pc
Minimum order quantity	1 pc
Product key	CL1151
GTIN	4063151215149
Weight per piece (including packing)	668.4 g
Weight per piece (excluding packing)	638 g
Country of origin	DE

VAL-EV-T1/T2 264/12.5/3+1 - Lightning/surge arrester type 1/2

1180149

<https://www.phoenixcontact.com/us/products/1180149>

Technical data

Product properties

Product type	Arrester combination
Product family	VALVETRAB MS
IEC test classification	I / II
	I
	T1 / T2
EN type	T1 / T2
IEC power supply system	TN-S
	TT
Type	DIN rail module, two-section, divisible
Number of positions	4
Surge protection fault message	optical
Number of ports	One

Insulation characteristics

Overvoltage category	III
Pollution degree	2

Electrical properties

Nominal frequency f_N	50 Hz (60 Hz)
-------------------------	---------------

Connection data

Connection method	Screw connection
Screw thread	M5
Tightening torque	3 Nm (1.5 mm ² ... 16 mm ²)
	4.5 Nm (25 mm ² ... 35 mm ²)
Stripping length	16 mm
Conductor cross-section flexible	1.5 mm ² ... 25 mm ²
Conductor cross-section rigid	1.5 mm ² ... 35 mm ²
Conductor cross-section AWG	15 ... 2
Connection method	Fork-type cable lug
Conductor cross-section flexible	1.5 mm ² ... 16 mm ²

Dimensions

Dimensional drawing	
Width	71.2 mm
Height	89.8 mm

VAL-EV-T1/T2 264/12.5/3+1 - Lightning/surge arrester type 1/2



1180149

<https://www.phoenixcontact.com/us/products/1180149>

Depth	77.5 mm (incl. DIN rail 7.5 mm)
Horizontal pitch	4 Div.

Material specifications

Color	light gray (RAL 7035)
Flammability rating according to UL 94	V-0
CTI value of material	600
Insulating material	PA 6.6/PBT
Material group	I
Housing material	PA 6.6 PBT

Mechanical properties

Mechanical data

Open side panel	No
-----------------	----

Protective circuit

Mode of protection	L-N
	L-PE
	N-PE
Direction of action	3L-N & N-PE
Nominal voltage U_N	240/415 V AC (TN-S)
	240/415 V AC (TT)
Nominal frequency f_N	50 Hz (60 Hz)
Maximum continuous operating voltage U_C	264 V AC
Rated load current I_L	80 A
Protective conductor current I_{PE}	$\leq 5 \mu\text{A}$
Standby power consumption P_C	$\leq 810 \text{ mVA}$
Nominal discharge current I_n (8/20) μs (L-N)	12.5 kA
Nominal discharge current I_n (8/20) μs (L-PE)	12.5 kA
Nominal discharge current I_n (8/20) μs (N-PE)	50 kA
Maximum discharge current I_{max} (8/20) μs	50 kA
Impulse discharge current (10/350) μs (L-N), charge	6.25 As
Impulse discharge current (10/350) μs (L-N), specific energy	39 kJ/ Ω
Impulse discharge current (10/350) μs (L-N), peak current value I_{imp}	12.5 kA
Impulse discharge current (10/350) μs (L-PE), charge	6.25 As
Impulse discharge current (10/350) μs (L-PE), specific energy	39 kJ/ Ω
Impulse discharge current (10/350) μs (L-PE), peak current value I_{imp}	12.5 kA
Impulse discharge current (10/350) μs (N-PE), charge	25 As
Impulse discharge current (10/350) μs (N-PE), specific energy	625 kJ/ Ω

VAL-EV-T1/T2 264/12.5/3+1 - Lightning/surge arrester type 1/2



1180149

<https://www.phoenixcontact.com/us/products/1180149>

Impulse discharge current (10/350) μs (N-PE), peak current value I_{imp}	50 kA
Total discharge current I_{Total} (8/20) μs	50 kA
Total discharge current I_{Total} (10/350) μs	50 kA
Follow current interrupt rating I_{fi} (N-PE)	100 A
Short-circuit current rating I_{SCCR}	25 kA
Voltage protection level U_p (L-N)	$\leq 1.2 \text{ kV}$ $\leq 1.6 \text{ kV}$ (30 kA - 8/20 μs)
Voltage protection level U_p (L-PE)	$\leq 2 \text{ kV}$
Voltage protection level U_p (N-PE)	$\leq 1.7 \text{ kV}$
Residual voltage U_{res} (L-N)	$\leq 1.2 \text{ kV}$ (at I_n) $\leq 1.1 \text{ kV}$ (at 10 kA) $\leq 1 \text{ kV}$ (at 5 kA) $\leq 0.9 \text{ kV}$ (at 3 kA)
Residual voltage U_{res} (L-PE)	$\leq 2 \text{ kV}$ (at I_n) $\leq 1.5 \text{ kV}$ (at 10 kA) $\leq 1.2 \text{ kV}$ (at 5 kA) $\leq 1.1 \text{ kV}$ (at 3 kA)
Residual voltage U_{res} (N-PE)	$\leq 0.6 \text{ kV}$ (at I_n) $\leq 0.5 \text{ kV}$ (at 10 kA) $\leq 0.5 \text{ kV}$ (at 5 kA) $\leq 0.4 \text{ kV}$ (at 3 kA)
TOV behavior at U_T (L-N)	415 V AC (5 s / withstand mode) 457 V AC (120 min / safe failure mode)
TOV behavior at U_T (N-PE)	1200 V AC (200 ms / withstand mode)
Response time t_A (L-N)	$\leq 25 \text{ ns}$
Response time t_A (L-PE)	$\leq 100 \text{ ns}$
Response time t_A (N-PE)	$\leq 100 \text{ ns}$
Max. backup fuse with V-type through wiring	80 A (gG - 16 mm ²)
Max. backup fuse with branch wiring	160 A (gG)

Environmental and real-life conditions

Ambient conditions

Degree of protection	IP20 (only when all terminal points are used)
Ambient temperature (operation)	-40 °C ... 80 °C
Ambient temperature (storage/transport)	-40 °C ... 80 °C
Altitude	$\leq 2000 \text{ m}$ (amsl)
Permissible humidity (operation)	5 % ... 95 %
Shock (operation)	30g (Half-sine / 11 ms / 3x $\pm X$, $\pm Y$, $\pm Z$)
Vibration (operation)	7.5g (10 ... 500 Hz / 2.5 h / X, Y, Z)

Standards and regulations

VAL-EV-T1/T2 264/12.5/3+1 - Lightning/surge arrester type 1/2



1180149

<https://www.phoenixcontact.com/us/products/1180149>

Standards/specifications	IEC 61643-11
Note	2011
Standards/specifications	EN 61643-11
Note	2012

Mounting

Mounting type	DIN rail: 35 mm
---------------	-----------------

VAL-EV-T1/T2 264/12.5/3+1 - Lightning/surge arrester type 1/2

1180149

<https://www.phoenixcontact.com/us/products/1180149>

Drawings

Dimensional drawing

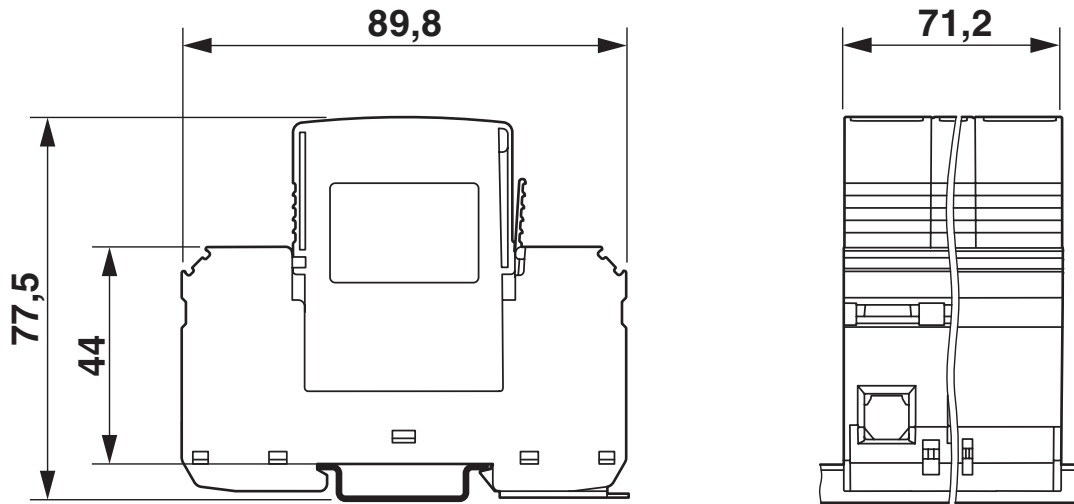

Circuit diagram

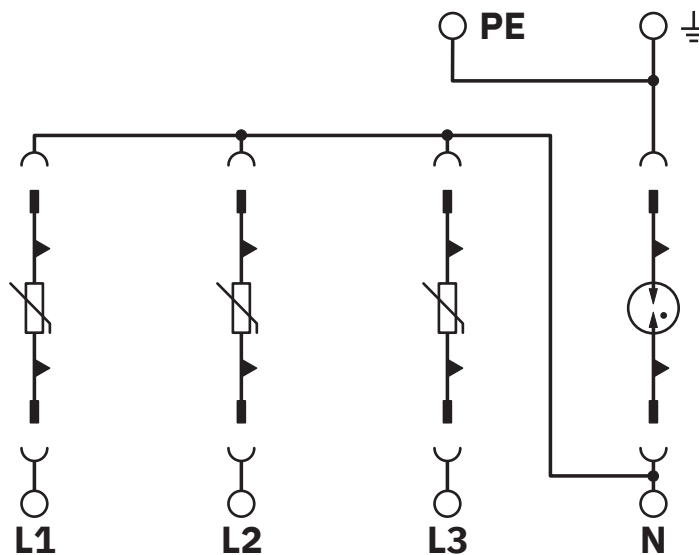

VAL-EV-T1/T2 264/12.5/3+1 - Lightning/surge arrester type 1/2



1180149

<https://www.phoenixcontact.com/us/products/1180149>

Approvals

To download certificates, visit the product detail page: <https://www.phoenixcontact.com/us/products/1180149>



KEMA-KEUR

Approval ID: 71-113415

VAL-EV-T1/T2 264/12.5/3+1 - Lightning/surge arrester type 1/2



1180149

<https://www.phoenixcontact.com/us/products/1180149>

Classifications

ECLASS

ECLASS-13.0	27171201
ECLASS-15.0	27171201

ETIM

ETIM 10.0	EC000381
-----------	----------

UNSPSC

UNSPSC 21.0	39121600
-------------	----------

VAL-EV-T1/T2 264/12.5/3+1 - Lightning/surge arrester type 1/2



1180149

<https://www.phoenixcontact.com/us/products/1180149>

Environmental product compliance

EU RoHS

Fulfills EU RoHS substance requirements	Yes, No exemptions
---	--------------------

China RoHS

Environment friendly use period (EFUP)	EFUP-E
	No hazardous substances above the limits

EU REACH SVHC

REACH candidate substance (CAS No.)	No substance above 0.1 wt%
-------------------------------------	----------------------------

EF3.1 Climate Change

CO2e kg	10.38 kg CO2e
---------	---------------

Phoenix Contact 2026 © - all rights reserved
<https://www.phoenixcontact.com>

Phoenix Contact USA
586 Fulling Mill Road
Middletown, PA 17057, United States
(+717) 944-1300
info@phoenixcon.com