

# EV-T2M3SO12-4P-B-SET - Infrastructure charging socket



1164417

<https://www.phoenixcontact.com/us/products/1164417>

Please be informed that the data shown in this PDF document is generated from our online catalog. Please find the complete data in the user documentation. Our general terms of use for downloads are valid.



CHARX connect modular, Type 2, Infrastructure charging socket, 32 A , 480 V AC, Basic, Set, without single-core wires, locking actuator: 12 V, 4-pos., square, Rear panel mounting, M5 thread, housing: black, with square protective cover, for charging electric vehicles (EV) with alternating current (AC), PHOENIX CONTACT logo, IEC 62196-2

## Product description

Infrastructure charging sockets with protective cover, for charging electric vehicles (EV) with alternating current (AC), compatible with Type 2 Infrastructure Plugs. For installation at charging stations for E-Mobility (EVSE)

## Your advantages

- Protected against overheating with precise temperature measurement
- Flexible mounting and easy maintenance with plug-in cables
- Available with your logo on request - for consistent branding of your charging station
- Waterproof and dirtproof due to fully molded contacts
- Developed and produced in accordance with the IATF 16949 automotive standard and ISO 9001
- Uniform, space-saving installation space

## Commercial data

Item number	1164417
Packing unit	1 pc
Minimum order quantity	1 pc
Sales key	EM01
Product key	XWBFLD
GTIN	4063151176075
Weight per piece (including packing)	541 g
Weight per piece (excluding packing)	21 g
Customs tariff number	85366990
Country of origin	PL

# EV-T2M3SO12-4P-B-SET - Infrastructure charging socket



1164417

<https://www.phoenixcontact.com/us/products/1164417>

## Set consists of

### EV-T2M3SO12-4P-B - Infrastructure charging socket

1164300

<https://www.phoenixcontact.com/us/products/1164300>



CHARX connect modular, Type 2, Infrastructure charging socket, 32 A , 480 V AC, Basic, without single-core wires, locking actuator: 12 V, 4-pos., square, Rear panel mounting, M5 thread, housing: black, for charging electric vehicles (EV) with alternating current (AC), PHOENIX CONTACT logo, IEC 62196-2

---

### EV-T2SOC-B - Protective cover

1164293

<https://www.phoenixcontact.com/us/products/1164293>



CHARX connect modular, Type 2, Protective cover, Basic, Accessories, square, Front mounting, M5 thread, with self-locking mechanism, for attachment to infrastructure charging sockets, Embossed PHOENIX CONTACT logo, IEC 62196-2

# EV-T2M3SO12-4P-B-SET - Infrastructure charging socket



1164417

<https://www.phoenixcontact.com/us/products/1164417>

## EV-T2M3SO-CAP - Protective cap

1202424

<https://www.phoenixcontact.com/us/products/1202424>



CHARX connect modular, Type 2, Protective cap, Gen 2, Accessories, circular, for strain relief and touch protection, IEC 62196-2

# EV-T2M3SO12-4P-B-SET - Infrastructure charging socket



1164417

<https://www.phoenixcontact.com/us/products/1164417>

## Technical data

### Product properties

Product type	Infrastructure charging socket
Product family	CHARX connect modular
Type	Gen 2 Basic Set
Design	with square protective cover
Compatibility	compatible with the CHARX connect modular Gen 2 product portfolio compatible with the CHARX connect protective cover product portfolio not compatible with CHARX connect modular Gen 3 cable sets
Charging standard	Type 2
Charging mode	Mode 3, Case B
Design (Infrastructure charging socket)	square square circular
Affixed logo	PHOENIX CONTACT logo
Customer variations	On request

### Electrical properties

#### Charging power and current (AC charging, 3-phase)

Type of charging current	AC 3-phase
Charging current	32 A AC (3-phase)
Charging power	26.6 kW (3-phase)
Charging power rating	22 kW (32 A, 3-phase)
Operating voltage	typ. 400 V AC

#### Pin assignment (Power contacts)

Note on the connection method	Connection via spade connector, separable and reconnectable
Number	5 (L1, L2, L3, N, PE)
Rated voltage	480 V AC
Rated current	32 A (The infrastructure charging socket is designed for both 1-phase and 3-phase charging with charging currents of up to 32 A.)

#### Pin assignment (Signal contacts)

Note on the connection method	Connection via spade connector, separable and reconnectable
Type of signal transmission	Pulse width modulation
Number	2 (CP, PP)
Rated voltage	30 V AC
Rated current	2 A

#### Locking actuator

# EV-T2M3SO12-4P-B-SET - Infrastructure charging socket



1164417

<https://www.phoenixcontact.com/us/products/1164417>

Locking actuator	12 V, 4-pos.
	Top center position
Possible power supply range at the motor	9 V ... 16 V
Maximum voltage for locking detection	30 V
Typical motor current for locking	0.2 A
Reverse current of the motor	max. 1 A
Max. dwell time with reverse current	1000 ms
Recommended adaptation time	600 ms
Pause time after entry or exit path	3 s
Service life insertion cycles	> 10000 load cycles
Lock recognition	available
Mechanical emergency release	available
Ambient temperature (operation)	-30 °C ... 50 °C
Cable length	0.5 m
Cable structure	4 x 0.5 mm <sup>2</sup>

## Dimensions

### Infrastructure charging socket

Dimensional drawing	
Width	75 mm
Height	91.71 mm
Depth	87.95 mm

### Bore dimensions

Dimensional drawing	
Width	60 mm
Height	60 mm

### Protective cap

Width	64 mm
Height	57 mm
Depth	24 mm

## Material specifications

Color (Housing)	black (9005)
-----------------	--------------

# EV-T2M3SO12-4P-B-SET - Infrastructure charging socket



1164417

<https://www.phoenixcontact.com/us/products/1164417>

Color (Protective cover)	black (9005)
Material (Housing)	Plastic
Material (Protective cover)	Plastic
Material (Contact surface)	Silver

## Cable/line

Cable type	without single-core wires Single-core wires for AC and communication are available separately, see accessories
------------	---

### Single-core wires for locking actuator

Cable length	0.5 m
Cable structure	4 x 0.5 mm <sup>2</sup>
Single wire, material	PVC
Single wire, color	BU/RD, BU/GN, BU/YE, BU/BN
External cable diameter	1.60 mm ±0.20 mm
Cable resistance	≤ 37.1 Ω/m

## Mechanical properties

Type of cover movement	Self-locking
------------------------	--------------

### Mechanical data

Insertion/withdrawal cycles	> 10000
Insertion force	< 100 N
Withdrawal force	< 100 N

## Environmental and real-life conditions

### Ambient conditions

Degree of protection (Infrastructure charging socket)	IP44 (plugged in)
Degree of protection (Protective cover)	IP54
Ambient temperature (operation)	-30 °C ... 50 °C
Ambient temperature (storage/transport)	-40 °C ... 80 °C
Altitude	5000 m (above sea level)

## Standards and regulations

Standards/specifications	IEC 62196-2
Note	Compliant with AFIR - EU 2025/656

## Mounting

Mounting type Infrastructure charging socket	Rear panel mounting (0 to 90 degree frontal inclination possible)
Mounting type Protective cover	Rear panel mounting
Mounting hole diameter	7.00 mm (ø)
Fixing screws	M5 thread
Screws included in the scope of delivery	none

# EV-T2M3SO12-4P-B-SET - Infrastructure charging socket



1164417

<https://www.phoenixcontact.com/us/products/1164417>

## Drawings

Dimensional drawing

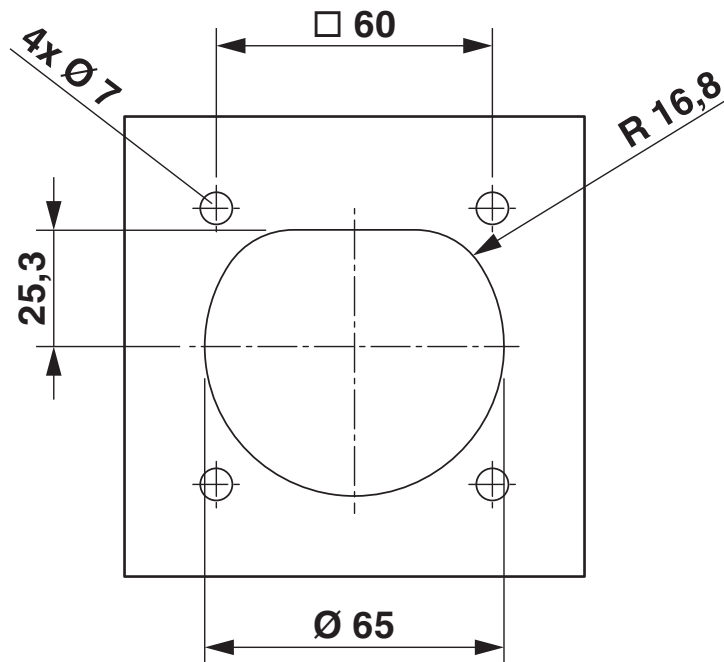

Dimensional drawing

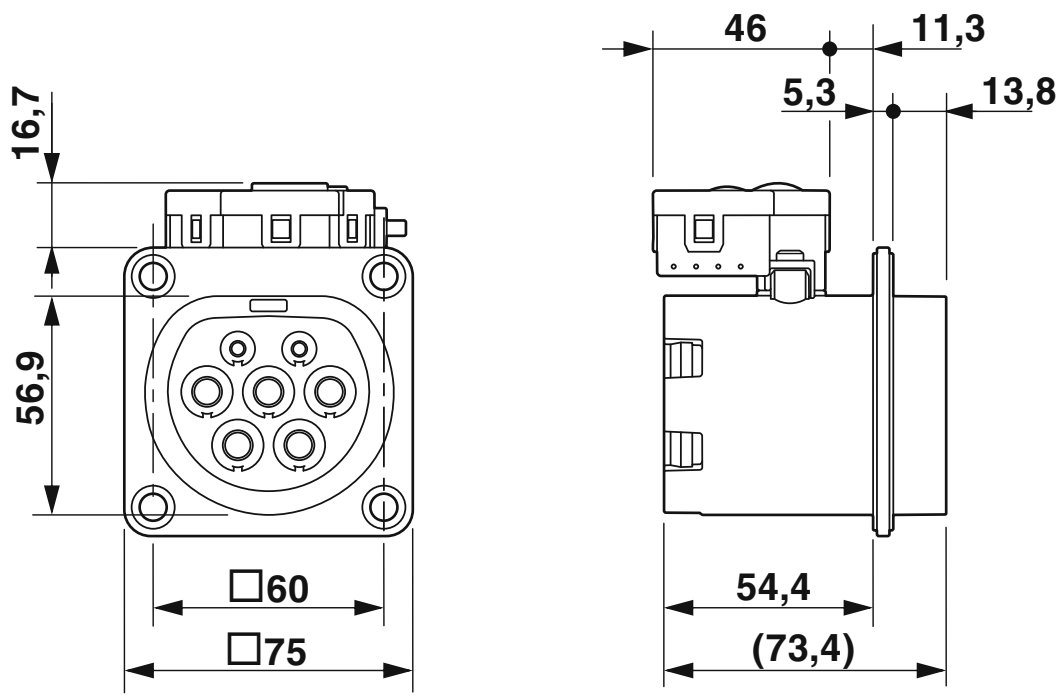

# EV-T2M3SO12-4P-B-SET - Infrastructure charging socket

1164417

<https://www.phoenixcontact.com/us/products/1164417>

Dimensional drawing

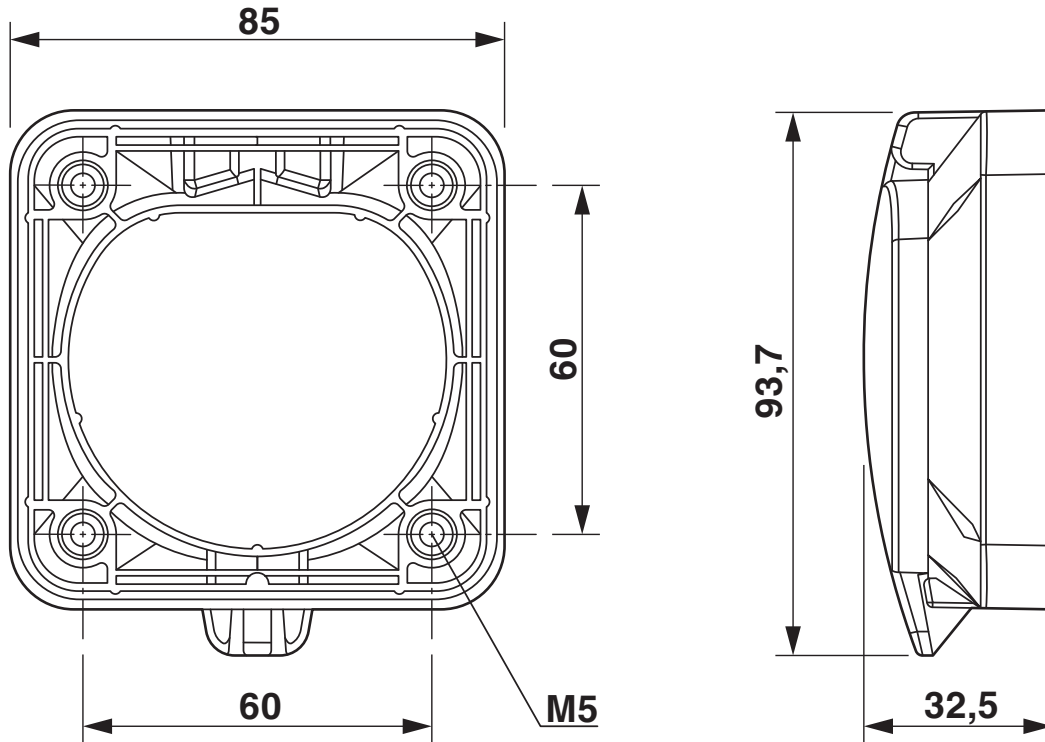

Connection diagram

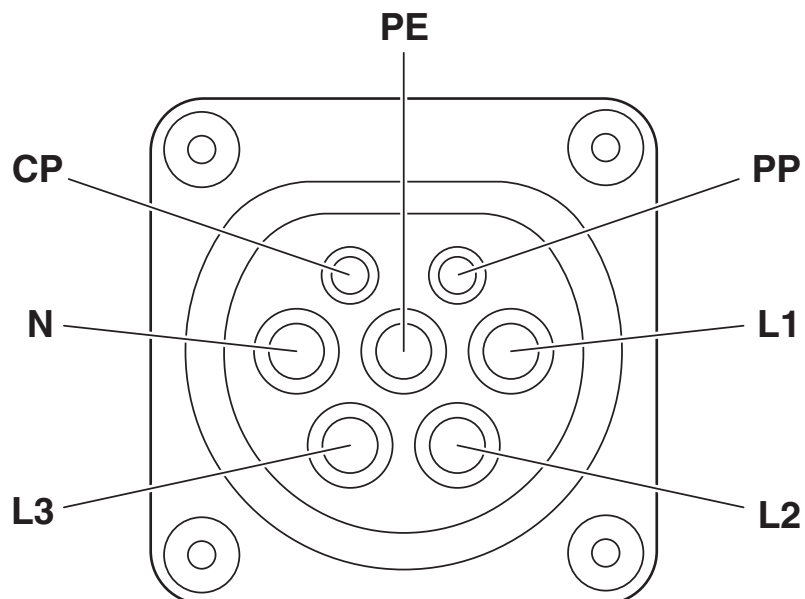

Pin assignment of infrastructure charging socket

# EV-T2M3SO12-4P-B-SET - Infrastructure charging socket

1164417

<https://www.phoenixcontact.com/us/products/1164417>

Schematic diagram

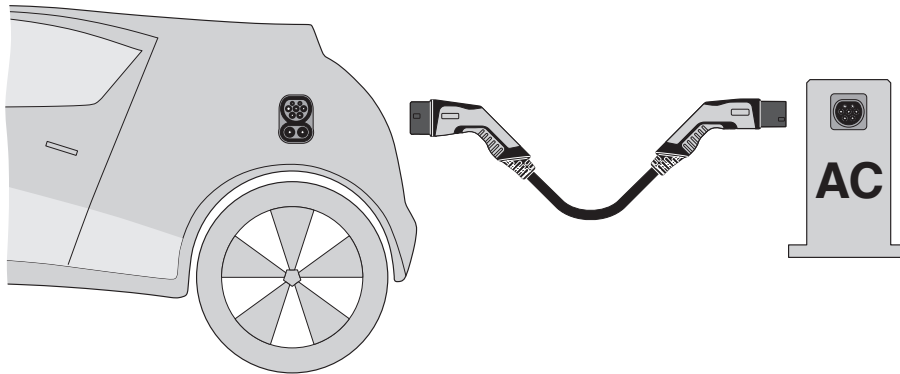

## Operating instructions

Schematic diagram

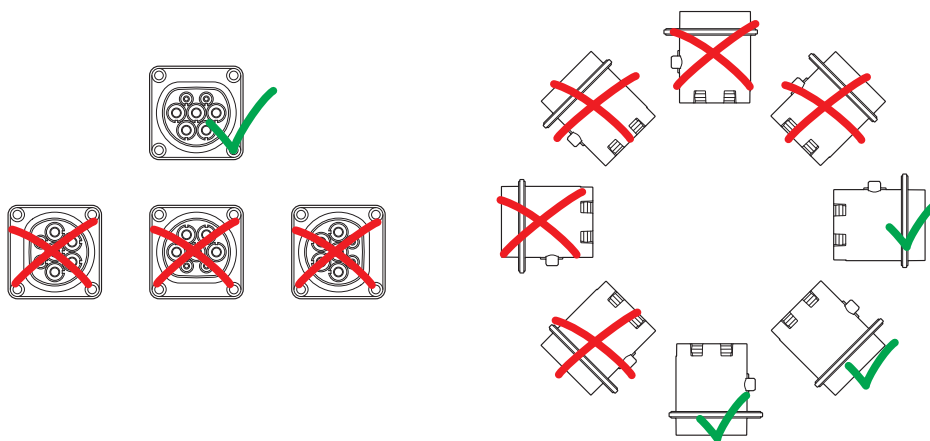

## Installation positions

# EV-T2M3SO12-4P-B-SET - Infrastructure charging socket



1164417

<https://www.phoenixcontact.com/us/products/1164417>

Schematic diagram

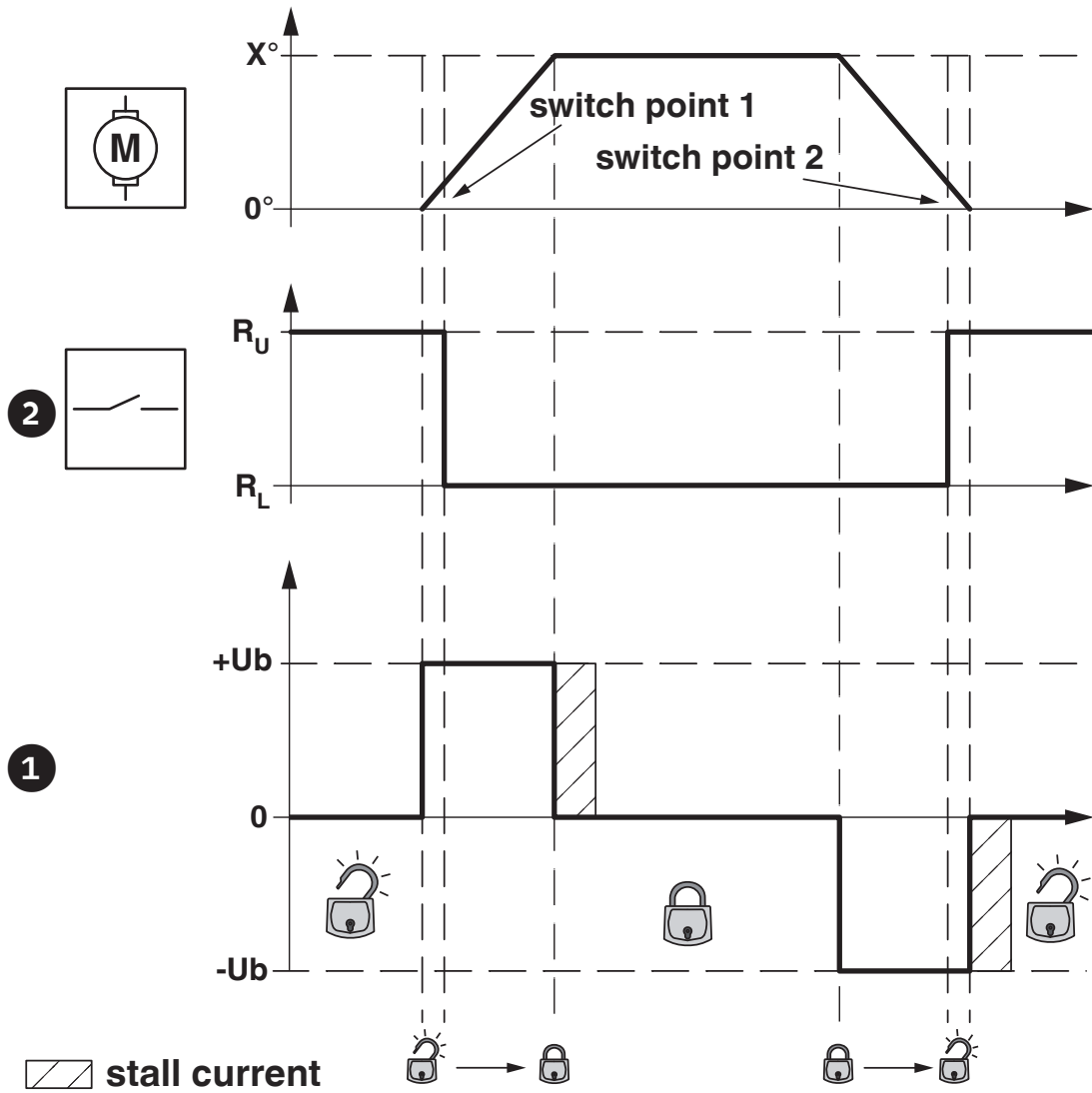

Locking states of the locking actuator

# EV-T2M3SO12-4P-B-SET - Infrastructure charging socket

1164417

<https://www.phoenixcontact.com/us/products/1164417>

Schematic diagram

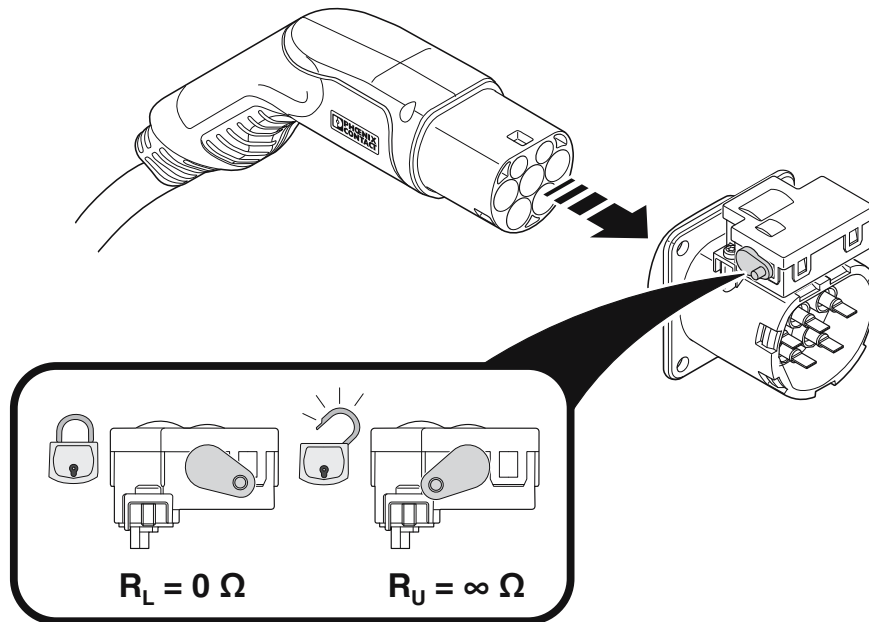

Position of the emergency unlocking lever on the locking actuator

Block diagram

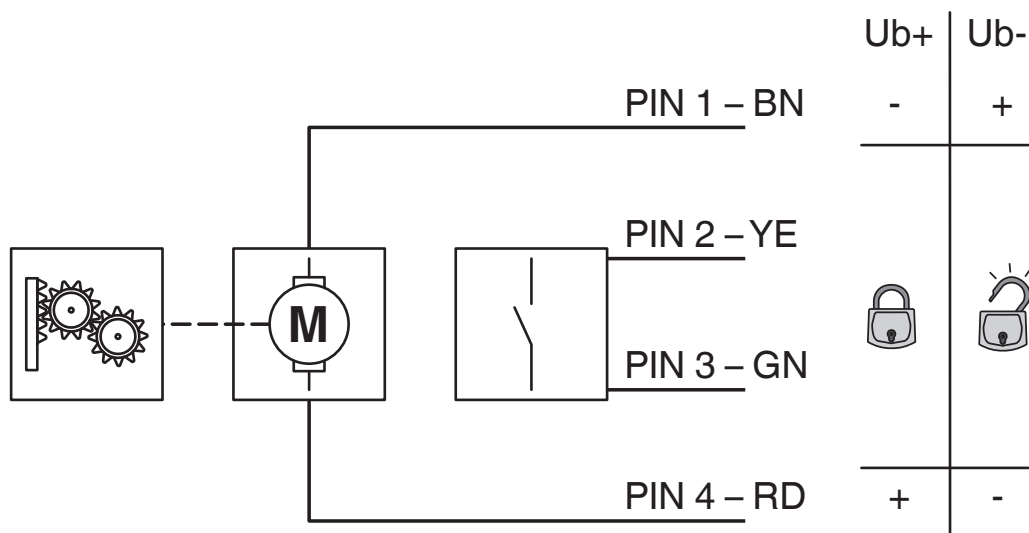

Block diagram of the locking actuator

# EV-T2M3SO12-4P-B-SET - Infrastructure charging socket



1164417

<https://www.phoenixcontact.com/us/products/1164417>

## Classifications

### ECLASS

ECLASS-13.0	27144706
ECLASS-15.0	27144706

### ETIM

ETIM 10.0	EC002898
-----------	----------

### UNSPSC

UNSPSC 21.0	39121800
-------------	----------

# EV-T2M3SO12-4P-B-SET - Infrastructure charging socket



1164417

<https://www.phoenixcontact.com/us/products/1164417>

## Environmental product compliance

### EU RoHS

Fulfills EU RoHS substance requirements	Yes
Exemption	6(c)

### China RoHS

Environment friendly use period (EFUP)	EFUP-10
	An article-related China RoHS declaration table can be found in the download area for the respective article under "Manufacturer declaration". For all articles with EFUP-E, no China RoHS declaration table issued and required.

### EU REACH SVHC

REACH candidate substance (CAS No.)	Lead(CAS: 7439-92-1)
SCIP	f6926433-3682-4c35-92e6-cfc6799ba01f

### EF3.1 Climate Change

CO2e kg	6.077 kg CO2e
---------	---------------

Phoenix Contact 2026 © - all rights reserved  
<https://www.phoenixcontact.com>

Phoenix Contact USA  
586 Fulling Mill Road  
Middletown, PA 17057, United States  
(+717) 944-1300  
[info@phoenixcon.com](mailto:info@phoenixcon.com)