

EV-T2M3SO12-4P-P - Infrastructure charging socket



1164299

<https://www.phoenixcontact.com/us/products/1164299>

Please be informed that the data shown in this PDF document is generated from our online catalog. Please find the complete data in the user documentation. Our general terms of use for downloads are valid.



CHARX connect modular, Type 2, Infrastructure charging socket, 32 A , 480 V AC, Premium, without single-core wires, locking actuator: 12 V, 4-pos., square, Rear panel mounting, M5 thread, housing: black, with temperature sensors, with LED (common cathode connection), for charging electric vehicles (EV) with alternating current (AC), PHOENIX CONTACT logo, IEC 62196-2

Product description

Infrastructure charging socket for charging electric vehicles (EV) with alternating current (AC), compatible with type 2 Infrastructure Plugs, for installation at charging stations for E-Mobility (EVSE)

Your advantages

- Protected against overheating with precise temperature measurement
- Flexible mounting and easy maintenance with plug-in cables
- Available with your logo on request - for consistent branding of your charging station
- Waterproof and dirtproof due to fully molded contacts
- Developed and produced in accordance with the IATF 16949 automotive standard and ISO 9001
- Uniform, space-saving installation space

Commercial data

Item number	1164299
Packing unit	1 pc
Minimum order quantity	1 pc
Sales key	EM01
Product key	XWBFLA
GTIN	4063151176662
Weight per piece (including packing)	441.9 g
Weight per piece (excluding packing)	157.6 g
Customs tariff number	85366990
Country of origin	PL

EV-T2M3SO12-4P-P - Infrastructure charging socket



1164299

<https://www.phoenixcontact.com/us/products/1164299>

Set consists of

EV-T2M3SO-CAP - Protective cap

1202424

<https://www.phoenixcontact.com/us/products/1202424>



CHARX connect modular, Type 2, Protective cap, Gen 2, Accessories, circular, for strain relief and touch protection, IEC 62196-2

EV-T2M3SO12-4P-P - Infrastructure charging socket



1164299

<https://www.phoenixcontact.com/us/products/1164299>

Technical data

Product properties

Product type	Infrastructure charging socket
Product family	CHARX connect modular
Type	Gen 2 Premium
Design	with temperature sensors with LED (common cathode connection)
Compatibility	compatible with the CHARX connect modular Gen 2 product portfolio compatible with the CHARX connect protective cover product portfolio not compatible with CHARX connect modular Gen 3 cable sets
Charging standard	Type 2
Charging mode	Mode 3, Case B
Design (Infrastructure charging socket)	square circular
Affixed logo	PHOENIX CONTACT logo
Customer variations	On request

Electrical properties

Temperature monitoring	PTC system (DIN EN 60738-1)
------------------------	-----------------------------

LED function

Application	to display the charging status
Position	in the frame of the protective cover
Connection type	common anode

Charging power and current (AC charging, 3-phase)

Type of charging current	AC 3-phase
Charging current	32 A AC (3-phase)
Charging power	26.6 kW (3-phase)
Charging power rating	22 kW (32 A, 3-phase)
Operating voltage	typ. 400 V AC

Pin assignment (Power contacts)

Note on the connection method	Connection via spade connector, separable and reconnectable
Number	5 (L1, L2, L3, N, PE)
Rated voltage	480 V AC
Rated current	32 A (The infrastructure charging socket is designed for both 1-phase and 3-phase charging with charging currents of up to 32 A.)

Pin assignment (Signal contacts)

Note on the connection method	Connection via spade connector, separable and reconnectable
Type of signal transmission	Pulse width modulation

EV-T2M3SO12-4P-P - Infrastructure charging socket



1164299

<https://www.phoenixcontact.com/us/products/1164299>

Number	2 (CP, PP)
Rated voltage	30 V AC
Rated current	2 A

Locking actuator

Locking actuator	12 V, 4-pos. Top center position
Possible power supply range at the motor	9 V ... 16 V
Maximum voltage for locking detection	30 V
Typical motor current for locking	0.2 A
Reverse current of the motor	max. 1 A
Max. dwell time with reverse current	1000 ms
Recommended adaptation time	600 ms
Pause time after entry or exit path	3 s
Service life insertion cycles	> 10000 load cycles
Lock recognition	available
Mechanical emergency release	available
Ambient temperature (operation)	-30 °C ... 50 °C
Cable length	0.5 m
Cable structure	4 x 0.5 mm ²

Temperature sensors (PTC chain)

Sensor type	PTC chain
Standards/regulations	DIN EN 60738-1
Diagnostics	Short circuit, cable break
Attachment point	Sensor for the AC contacts
Measuring range_resistance	800 Ω ... 300 kΩ
Resistance	max. 10 Ω
Recommended measured current	≤ 1 mA (U _{max} = 24 V DC)

Dimensions

Infrastructure charging socket

Dimensional drawing	<p>The drawing shows two views of the charging socket. The front view (left) shows a square face with a width of 75 mm and a height of 56.9 mm. The side view (right) shows a depth of 87.95 mm. Other dimensions include 16.7 mm for the top edge, 46 mm for the top width, 11.3 mm for the top offset, 5.3 mm for the top thickness, 13.8 mm for the top depth, 60 mm for the inner width, and 54.4 mm (73.4 mm total) for the bottom width.</p>
Width	75 mm
Height	91.71 mm
Depth	87.95 mm

Bore dimensions

EV-T2M3SO12-4P-P - Infrastructure charging socket



1164299

<https://www.phoenixcontact.com/us/products/1164299>

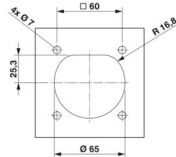
Dimensional drawing	
Width	60 mm
Height	60 mm

Protective cap	
Width	64 mm
Height	57 mm
Depth	24 mm

Material specifications

Color (Housing)	black (9005)
Material (Housing)	Plastic
Material (Contact surface)	Silver

Cable/line

Cable type	without single-core wires Single-core wires for AC and communication are available separately, see accessories
------------	---

Single-core wires for locking actuator

Cable length	0.5 m
Cable structure	4 x 0.5 mm ²
Single wire, material	PVC
Single wire, color	BU/RD, BU/GN, BU/YE, BU/BN
External cable diameter	1.60 mm ±0.20 mm
Cable resistance	≤ 37.1 Ω/m

Single-core wires for PTC temperature sensors

Cable length	0.5 m
Cable structure	5 x 0,5 mm ²
Single wire, material	PVC
Single wire, color	BN/GY BN/YE/GN
External cable diameter	1.60 mm ±0.20 mm
Cable resistance	≤ 37.1 Ω/m

Mechanical properties

Mechanical data	
Insertion/withdrawal cycles	> 10000
Insertion force	< 100 N
Withdrawal force	< 100 N

EV-T2M3SO12-4P-P - Infrastructure charging socket



1164299

<https://www.phoenixcontact.com/us/products/1164299>

Environmental and real-life conditions

Ambient conditions

Degree of protection (Infrastructure charging socket)	IP44 (plugged in)
Degree of protection (Protective cover)	IP54 (see accessories)
Ambient temperature (operation)	-30 °C ... 50 °C
Ambient temperature (storage/transport)	-40 °C ... 80 °C
Altitude	5000 m (above sea level)

Standards and regulations

Standards/specifications	IEC 62196-2
Note	Compliant with AFIR - EU 2025/656

Mounting

Mounting type Infrastructure charging socket	Rear panel mounting (0 to 90 degree frontal inclination possible)
Mounting type Protective cover	Rear panel mounting (available separately)
Mounting hole diameter	7.00 mm (ø)
Fixing screws	M5 thread
Screws included in the scope of delivery	none

EV-T2M3SO12-4P-P - Infrastructure charging socket

1164299

<https://www.phoenixcontact.com/us/products/1164299>

Drawings

Dimensional drawing

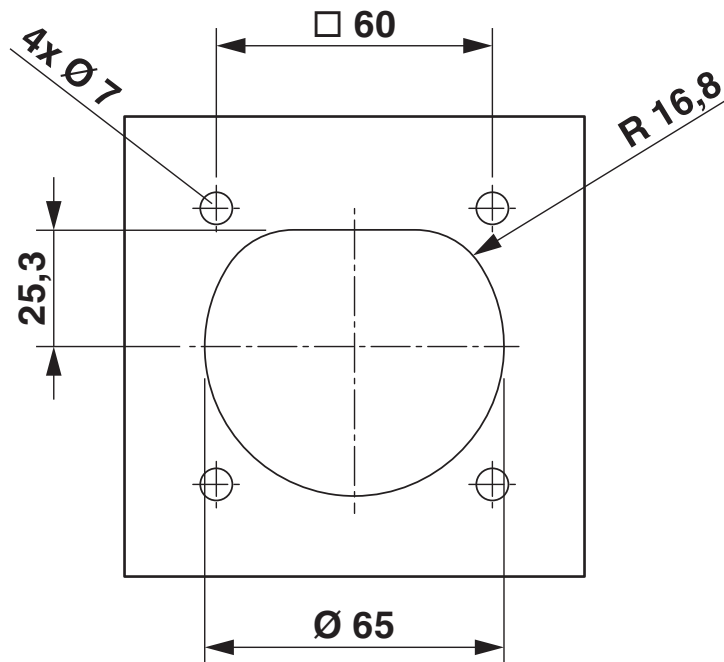

Dimensional drawing

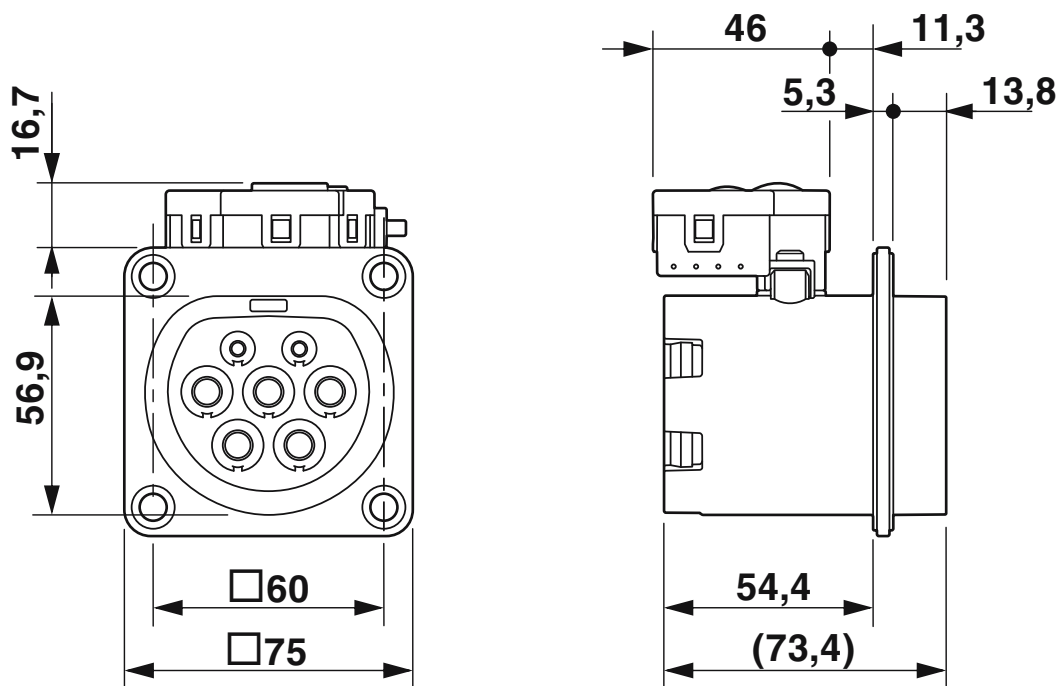

EV-T2M3SO12-4P-P - Infrastructure charging socket

1164299

<https://www.phoenixcontact.com/us/products/1164299>

Dimensional drawing

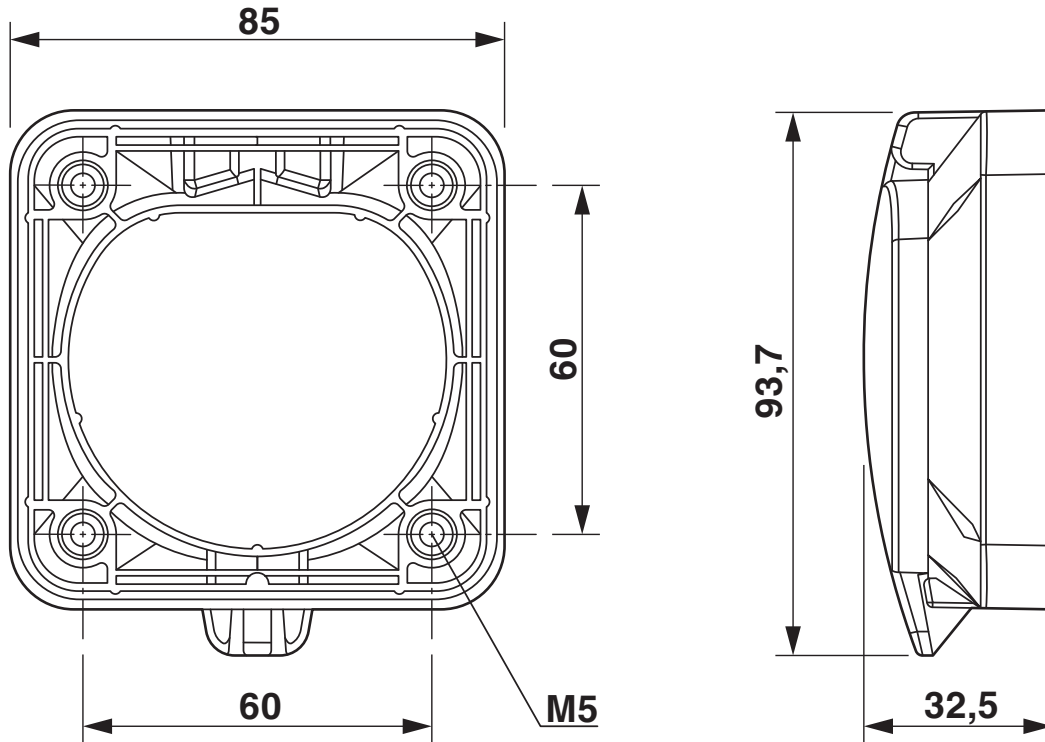

Connection diagram

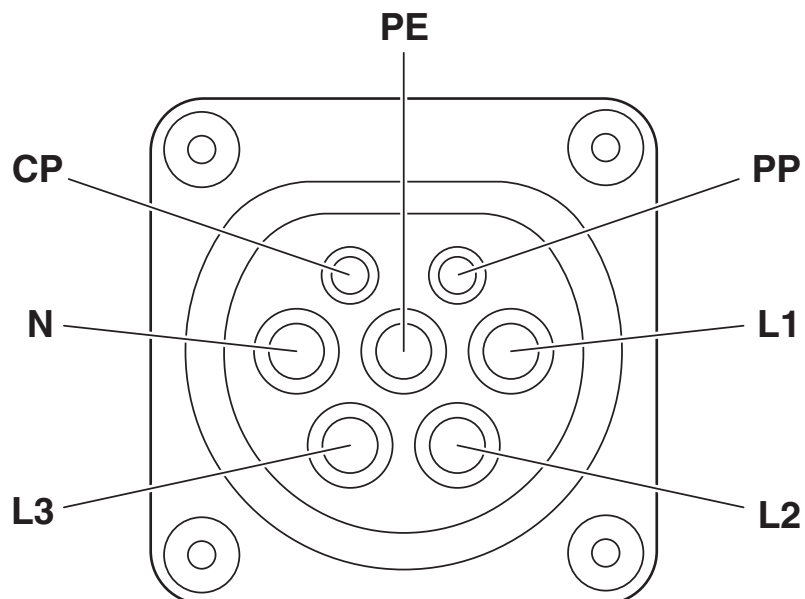

Pin assignment of infrastructure charging socket

EV-T2M3SO12-4P-P - Infrastructure charging socket

1164299

<https://www.phoenixcontact.com/us/products/1164299>

Schematic diagram

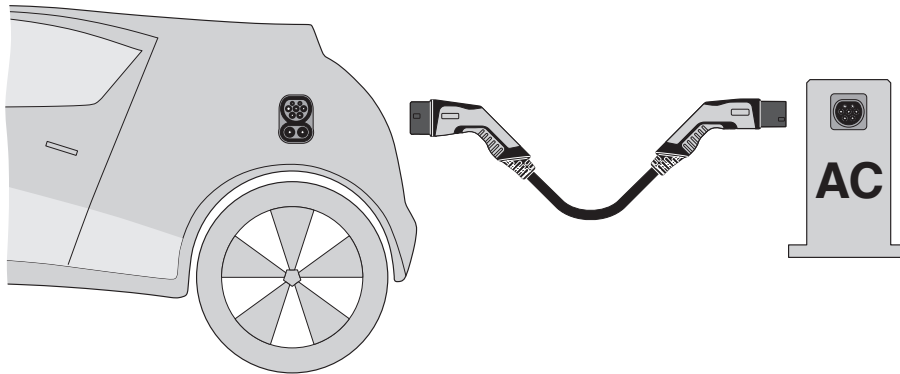

Operating instructions

Schematic diagram

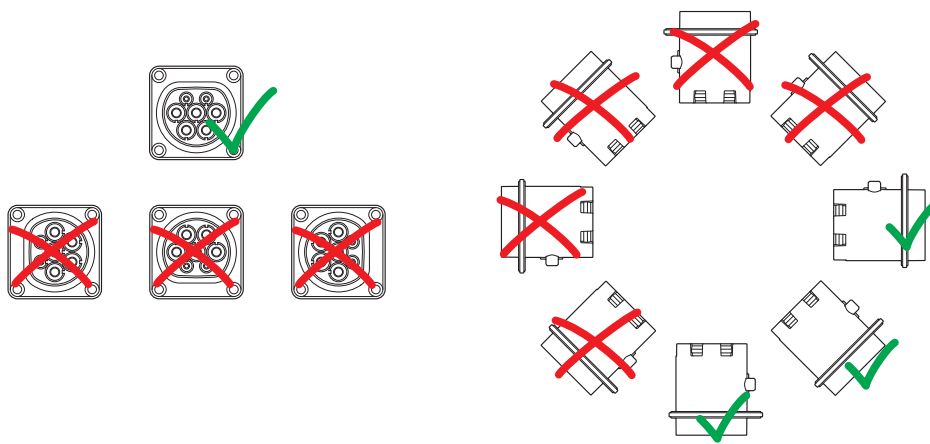

Installation positions

1164299

<https://www.phoenixcontact.com/us/products/1164299>

Schematic diagram

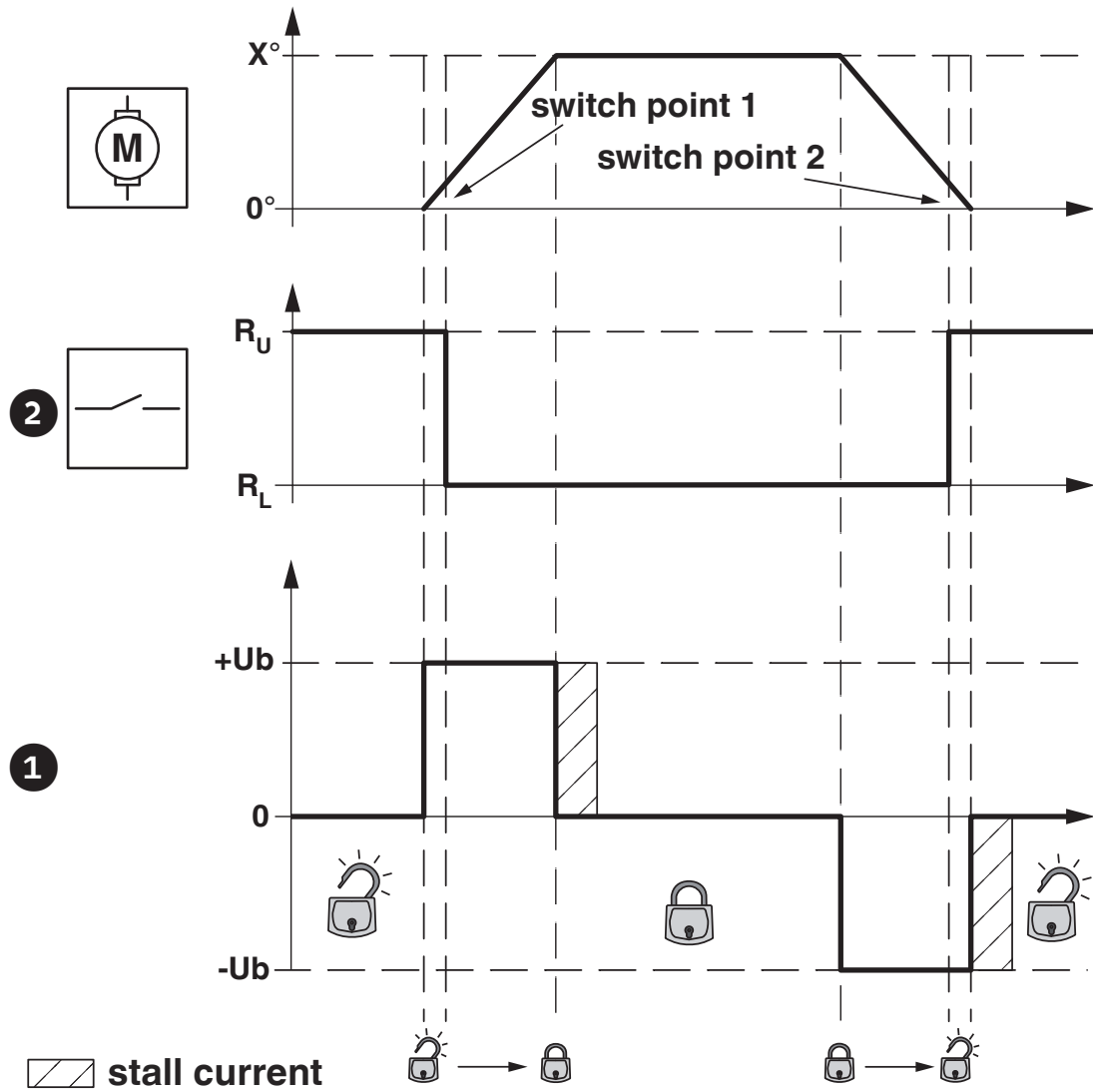

Locking states of the locking actuator

EV-T2M3SO12-4P-P - Infrastructure charging socket

1164299

<https://www.phoenixcontact.com/us/products/1164299>

Schematic diagram

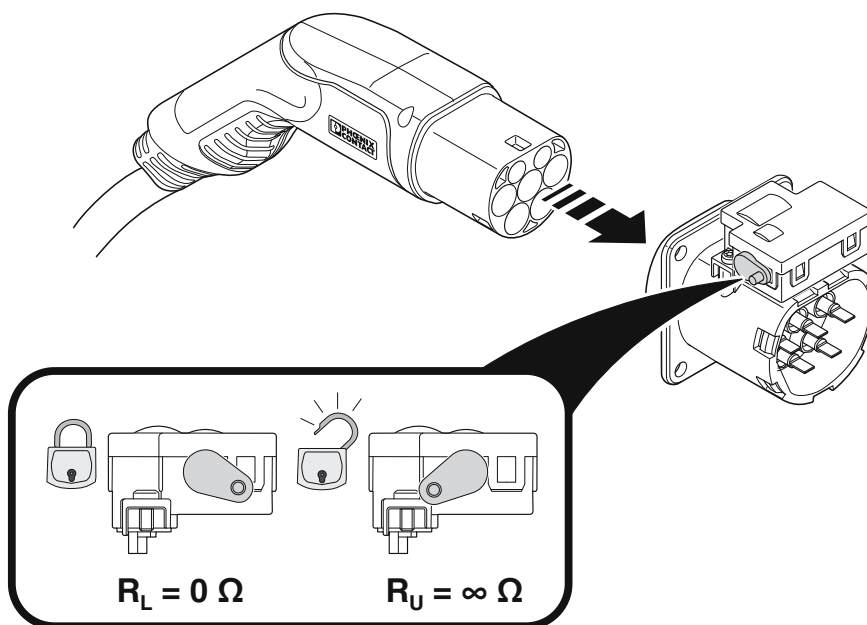

Position of the emergency unlocking lever on the locking actuator

Block diagram

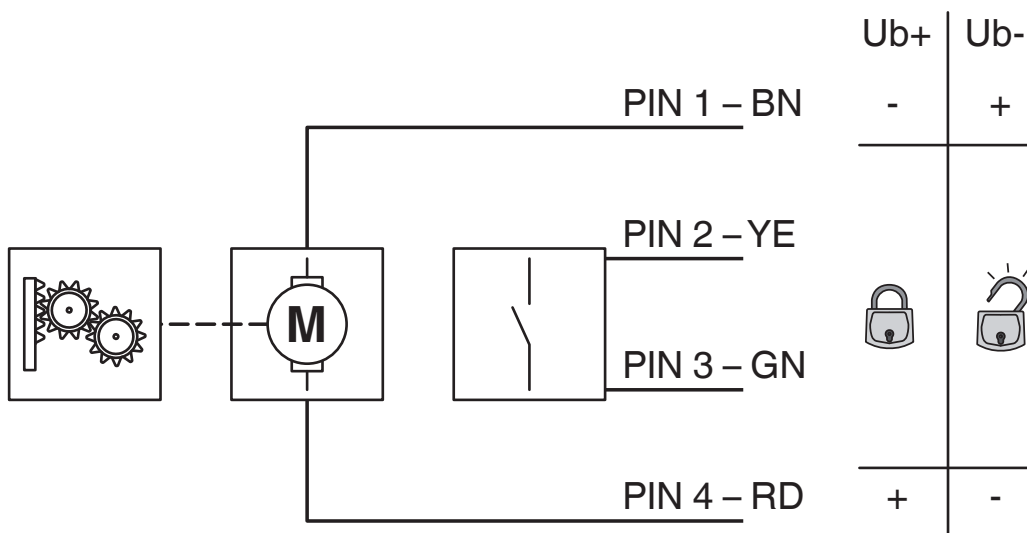

Block diagram of the locking actuator

EV-T2M3SO12-4P-P - Infrastructure charging socket



1164299

<https://www.phoenixcontact.com/us/products/1164299>

Classifications

ECLASS

ECLASS-13.0	27144706
ECLASS-15.0	27144706

ETIM

ETIM 10.0	EC002898
-----------	----------

UNSPSC

UNSPSC 21.0	39121800
-------------	----------

1164299

<https://www.phoenixcontact.com/us/products/1164299>

Environmental product compliance

EU RoHS

Fulfills EU RoHS substance requirements	Yes
Exemption	6(c), 7(c)-I

China RoHS

Environment friendly use period (EFUP)	EFUP-10
	An article-related China RoHS declaration table can be found in the download area for the respective article under "Manufacturer declaration". For all articles with EFUP-E, no China RoHS declaration table issued and required.

EU REACH SVHC

REACH candidate substance (CAS No.)	Lead(CAS: 7439-92-1)
SCIP	3dc759bd-b4c6-4661-aa94-67b4e4e7353b

EF3.1 Climate Change

CO2e kg	5.047 kg CO2e
---------	---------------

Phoenix Contact 2026 © - all rights reserved
<https://www.phoenixcontact.com>

Phoenix Contact USA
 586 Fulling Mill Road
 Middletown, PA 17057, United States
 (+717) 944-1300
info@phoenixcon.com