

EV-T2SOC-B - Protective cover



1164293

<https://www.phoenixcontact.com/us/products/1164293>

Please be informed that the data shown in this PDF document is generated from our online catalog. Please find the complete data in the user documentation. Our general terms of use for downloads are valid.



CHARX connect modular, Type 2, Protective cover, Basic, Accessories, square, Front mounting, M5 thread, with self-locking mechanism, for attachment to infrastructure charging sockets, Embossed PHOENIX CONTACT logo, IEC 62196-2

Product description

Self-closing protective cover for infrastructure charging socket

Your advantages

- Developed and produced in accordance with the IATF 16949 automotive standard and ISO 9001
- Individual branding, thanks to the use your own logo
- Reliable protection of your socket outlet from weather and vandalism

Commercial data

Item number	1164293
Packing unit	1 pc
Minimum order quantity	1 pc
Sales key	EM01
Product key	XWBFLC
GTIN	4063151177324
Weight per piece (including packing)	97.7 g
Weight per piece (excluding packing)	97.7 g
Customs tariff number	39269097
Country of origin	PL

EV-T2SOC-B - Protective cover



1164293

<https://www.phoenixcontact.com/us/products/1164293>

Technical data

Product properties

Product type	Protective cover for Socket Outlet
Product family	CHARX connect modular
Type	Gen 2 Basic Accessories
Design	with self-locking mechanism
Compatibility	compatible with all CHARX connect infrastructure charging sockets compatible with CHARX connect modular shutters
Charging standard	Type 2
Charging mode	Mode 3, Case B
Design (Protective cover)	square
Affixed logo	Embossed PHOENIX CONTACT logo
Customer variations	On request

Dimensions

Protective cover

Dimensional drawing	
Width	85 mm
Height	93.7 mm
Depth	32.5 mm

Bore dimensions

Dimensional drawing	
Width	60 mm
Height	60 mm

Material specifications

Color (Protective cover)	black (9005)
Material (Protective cover)	Plastic

Mechanical properties

EV-T2SOC-B - Protective cover



1164293

<https://www.phoenixcontact.com/us/products/1164293>

Type of cover movement	Self-locking
------------------------	--------------

Environmental and real-life conditions

Ambient conditions

Degree of protection (Protective cover)	IP54
	IK08
Ambient temperature (operation)	-30 °C ... 50 °C
Ambient temperature (storage/transport)	-40 °C ... 80 °C
Altitude	5000 m (above sea level)

Standards and regulations

Standards/specifications	IEC 62196-2
Note	Compliant with AFIR - EU 2025/656

Mounting

Mounting type Protective cover	Front mounting (rear screw connection, the associated infrastructure charging socket can be attached from the rear or from the front)
Fixing screws	M5 thread

EV-T2SOC-B - Protective cover

1164293

<https://www.phoenixcontact.com/us/products/1164293>

Drawings

Dimensional drawing

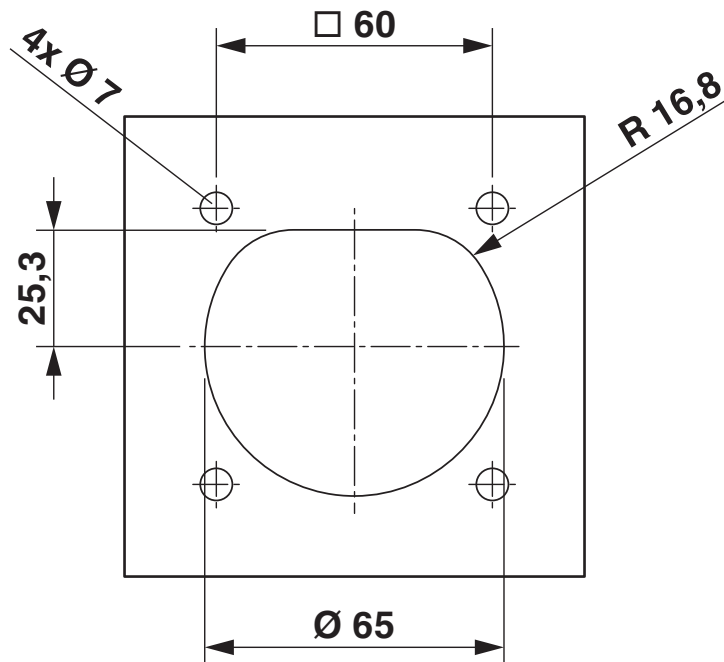

Dimensional drawing

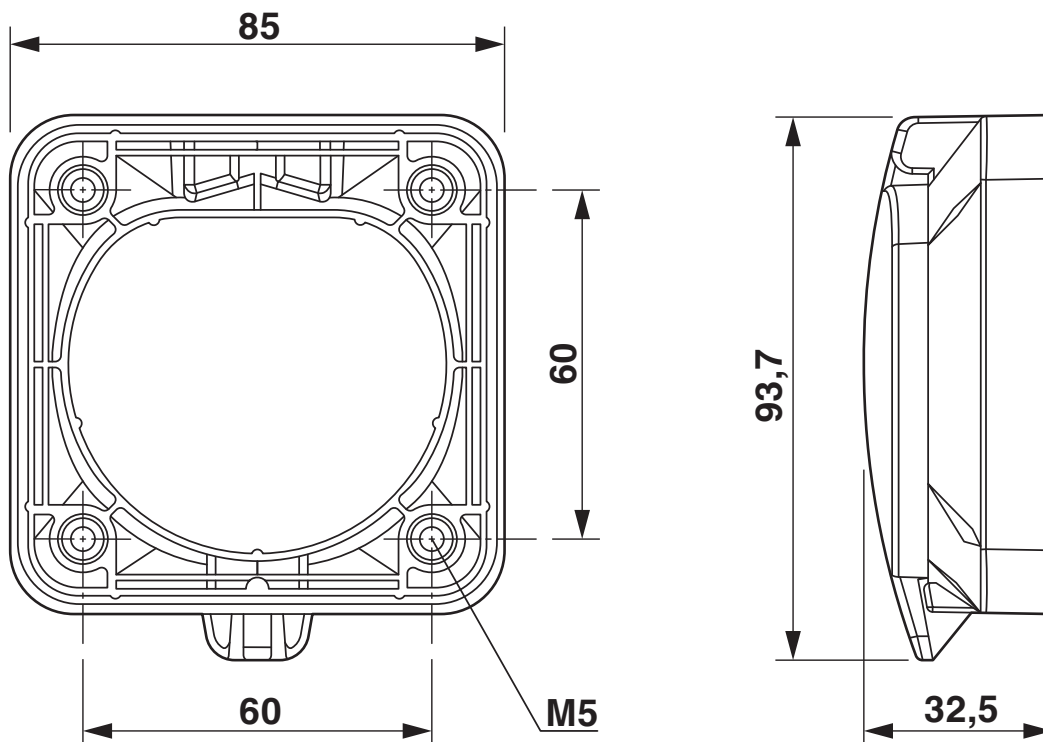

EV-T2SOC-B - Protective cover

1164293

<https://www.phoenixcontact.com/us/products/1164293>

Schematic diagram

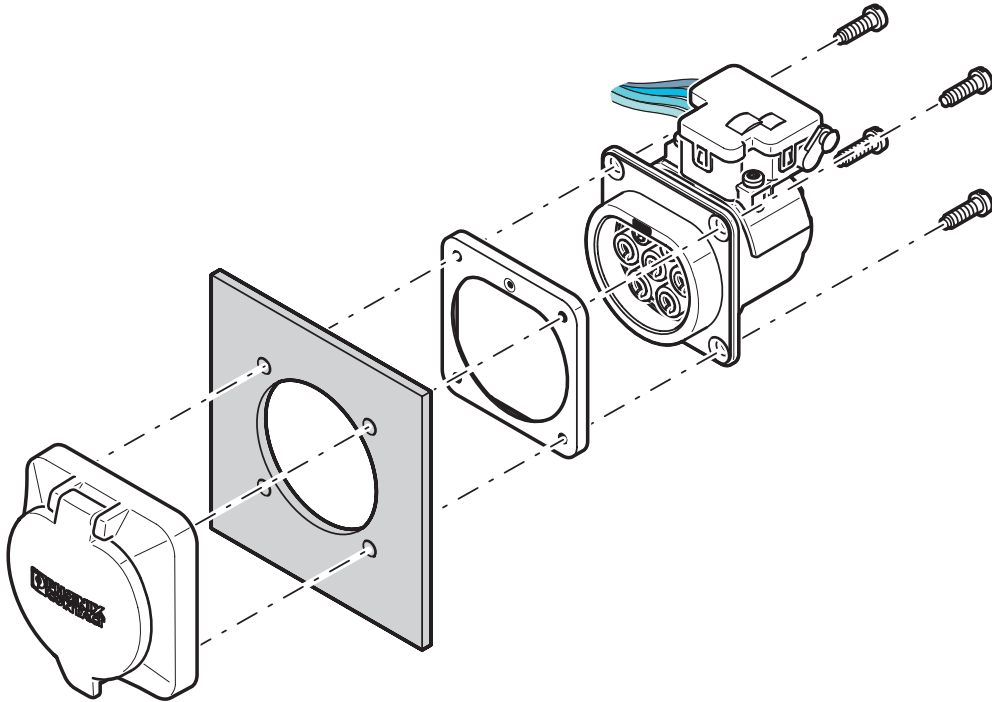

Rear mounting with rear protective cover screw connection

The screw connection for a protective cover from the accessories range (EV-T2SC) only supports rear mounting. The panel thickness must not exceed 5 mm. The sealing frame that is slid on from the rear must contact the housing panel flush with the flat side and must completely surround the infrastructure socket outlet.

EV-T2SOC-B - Protective cover

1164293

<https://www.phoenixcontact.com/us/products/1164293>

Schematic diagram

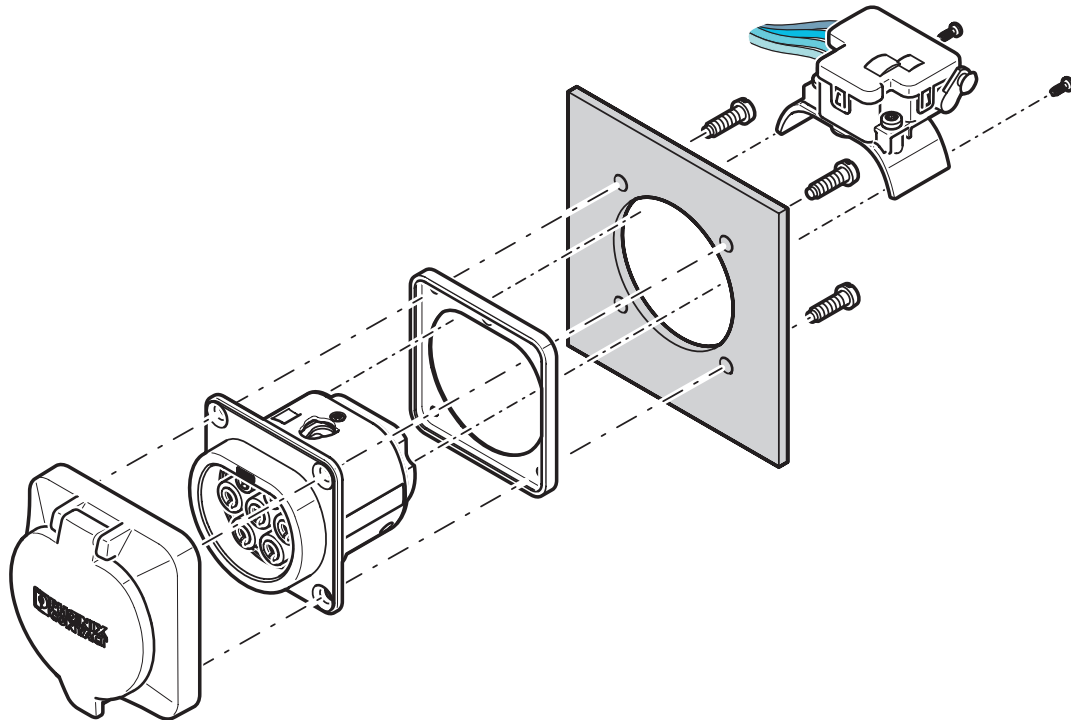

Front mounting with rear protective cover screw connection

Front mounting is only possible when the locking actuator is removed. We recommend using an infrastructure socket outlet without pre-assembled locking actuator (EV-T2M3SE-...E0..., e.g., 1621729).

The screw connection for a protective cover from the accessories range (EV-T2SC) only supports rear mounting. The panel thickness must not exceed 10 mm. The sealing frame that is slid on from the front must contact the housing panel flush with the flat side and must completely surround the infrastructure socket outlet.

EV-T2SOC-B - Protective cover



1164293

<https://www.phoenixcontact.com/us/products/1164293>

Classifications

ECLASS

ECLASS-13.0	27144792
ECLASS-15.0	27144792

ETIM

ETIM 10.0	EC002884
-----------	----------

UNSPSC

UNSPSC 21.0	39121500
-------------	----------

EV-T2SOC-B - Protective cover



1164293

<https://www.phoenixcontact.com/us/products/1164293>

Environmental product compliance

EU RoHS

Fulfills EU RoHS substance requirements	Not applicable, No electrical and electronic equipment (EEE), cannot be used in EEE
-----------------------------------------	-------------------------------------------------------------------------------------

EU REACH SVHC

REACH candidate substance (CAS No.)	No substance above 0.1 wt%
-------------------------------------	----------------------------

Phoenix Contact 2026 © - all rights reserved

<https://www.phoenixcontact.com>

Phoenix Contact USA
586 Fulling Mill Road
Middletown, PA 17057, United States
(+717) 944-1300
info@phoenixcon.com