

FL WLAN 2011 - Wireless module

1119248

<https://www.phoenixcontact.com/us/products/1119248>

Please be informed that the data shown in this PDF document is generated from our online catalog. Please find the complete data in the user documentation. Our general terms of use for downloads are valid.



The figure shows a version of the product

WLAN access point, client, mesh for USA and Canada, with two external antenna connections (RSMA-F), IP20, WLAN 802.11a, b, g, n, frequency: 2.4 GHz, 5 GHz, connections: COMBICON 9 V DC ... 32 V DC, RJ45: for LAN, web, http/https, CLI, REST API

Commercial data

Item number	1119248
Packing unit	1 pc
Minimum order quantity	1 pc
Sales key	DN26
Product key	DNN2W4
GTIN	4063151048853
Weight per piece (including packing)	263 g
Weight per piece (excluding packing)	248.3 g
Customs tariff number	85176200
Country of origin	DE

Technical data

Notes

Note on application

Note on application	Only for industrial use
---------------------	-------------------------

Product properties

Product type	Wireless module
Application	Ethernet
Type	Stand-alone

Insulation characteristics

Pollution degree	2
------------------	---

Wireless card

Number	1
Type	IEEE 802.11 a/b/g/n 2.4 GHz and 5 GHz to 300 Mbps
Assembly note	Permanently installed

Electrical properties

Maximum power dissipation for nominal condition	4.1 W
---	-------

Supply: Module electronics

Connection technology	COMBICON
Connection method	Push-in spring connection
Note on the connection method	Recommended conductor cross-section: 0.75 mm ²
	Recommended ferrule: connection length 10 mm
	Recommended crimping pliers: trapezoidal or square
Designation	1128752 FMC 1,5/ 3-ST-3,5-RF GY35BD1-3
Number of positions	3
Cross section range AWG	24 ... 16 (Use copper wires rated 75° C (UL))
Supply voltage	24 V DC (SELV)
Supply voltage range	9 V DC ... 32 V DC (PELV/SELV)
Supply current	typ. 170 mA (at 24 V DC)
Current consumption	max. 600 mA (at 9 V DC)

Connection data

1128752 FMC 1,5/ 3-ST-3,5-RF GY35BD1-3

Connection method	Push-in spring connection
pluggable	yes
Conductor cross-section, rigid	0.2 mm ² ... 1.5 mm ²
Conductor cross-section, flexible	0.2 mm ² ... 1.5 mm ²
Conductor cross-section AWG	24 ... 16
Stripping length	10 mm

1119248

<https://www.phoenixcontact.com/us/products/1119248>

Interfaces

Antenna

Number	2
--------	---

Functions

Configuration	Web-based management, automated CLI
Quality of service (QoS)	Yes
Security	802.11i
	WPA PSK (preshared key)
	WPA2
	AES
	TKIP
	MAC filter
Supports 802.1X/RADIUS	
Wireless licenses	USA, Canada

Ethernet (RJ45)

Number of interfaces	1
Connection method	RJ45
Note on the connection method	Auto negotiation and autocrossing
Transmission speed	10/100 Mbps
Transmission physics	Copper
Transmission length	100 m (per segment)
No. of channels	1 (RJ45 ports)

Wireless

Designation	Wireless LAN
Antenna connection method	RSMA (female)
Frequency band	2.4 GHz
	5 GHz
Wireless standard	WLAN
	IEEE 802.11
	a
	b
	g
	n
Wi-Fi 4	
Transmission power	max. 19 dBm (with two antennas)
Number of wireless interfaces	1 IEEE 802. 11 a/b/g/n
Wireless modules that can be connected	60 (In access point mode)

Dimensions

1119248

<https://www.phoenixcontact.com/us/products/1119248>

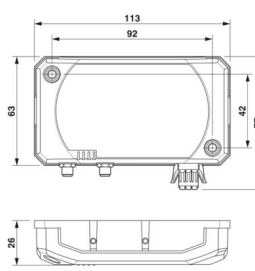
Dimensional drawing	
Width	63 mm
Height	26 mm
Depth	113 mm
Note on dimensions	Installed dimensions without connector

Material specifications

Material base plate	Die-cast zinc, nickel-plated
Housing material	PC

Environmental and real-life conditions

Ambient conditions

Ambient temperature (operation)	-40 °C ... 60 °C
Degree of protection	IP20
Air pressure (operation)	800 hPa ... 1080 hPa (up to 2000 m above sea level)
Air pressure (storage/transport)	660 hPa ... 1080 hPa (up to 3500 m above sea level)
Ambient temperature (storage/transport)	-40 °C ... 85 °C
Permissible humidity (operation)	5 % ... 95 % (non-condensing)
Permissible humidity (storage/transport)	5 % ... 95 % (non-condensing)

Mechanical test

Shock in accordance with EN 60068-2-27/IEC 60068-2-27	30g, 11 ms half-sine shock pulse
Vibration resistance in accordance with EN 60068-2-6/IEC 60068-2-6	5g, 10 ... 150 Hz
Continuous shock in accordance with EN 60068-2-27/IEC 60068-2-27	10g, 16 ms, 6000 shocks
Broadband noise in accordance with EN 60068-2-64	Category 1, Class A

EMC data

Electrostatic discharge

Standards/regulations	EN 61000-4-2
-----------------------	--------------

Electrostatic discharge

Contact discharge	± 6 kV
Discharge in air	± 8 kV
Indirect discharge	± 6 kV

Electromagnetic HF field

FL WLAN 2011 - Wireless module



1119248

<https://www.phoenixcontact.com/us/products/1119248>

Standards/regulations	EN 61000-4-3
-----------------------	--------------

Electromagnetic HF field

Frequency range	80 MHz ... 1000 MHz
Test field strength	10 V/m
Frequency range	1000 MHz ... 6000 MHz
Test field strength	3 V/m

Fast transients (burst)

Standards/regulations	EN 61000-4-4
-----------------------	--------------

Fast transients (burst)

Comments	±2.2 kV
----------	---------

Surge current load (surge)

Standards/regulations	EN 61000-4-5
-----------------------	--------------

Surge current load (surge)

Signal	± 0.5 kV (symmetrical)
	± 1 kV (asymmetrical)

Conducted interference

Standards/regulations	EN 61000-4-6
-----------------------	--------------

Conducted interference

Frequency range	0.15 MHz ... 80 MHz
Voltage	10 V

Emitted interference

Standards/regulations	EN 55022
Test result	Class B

Mounting

Mounting type	Panel mounting
	DIN rail mounting
Assembly note	Antennas not included in scope of supply

FL WLAN 2011 - Wireless module



1119248

<https://www.phoenixcontact.com/us/products/1119248>

Drawings

Dimensional drawing

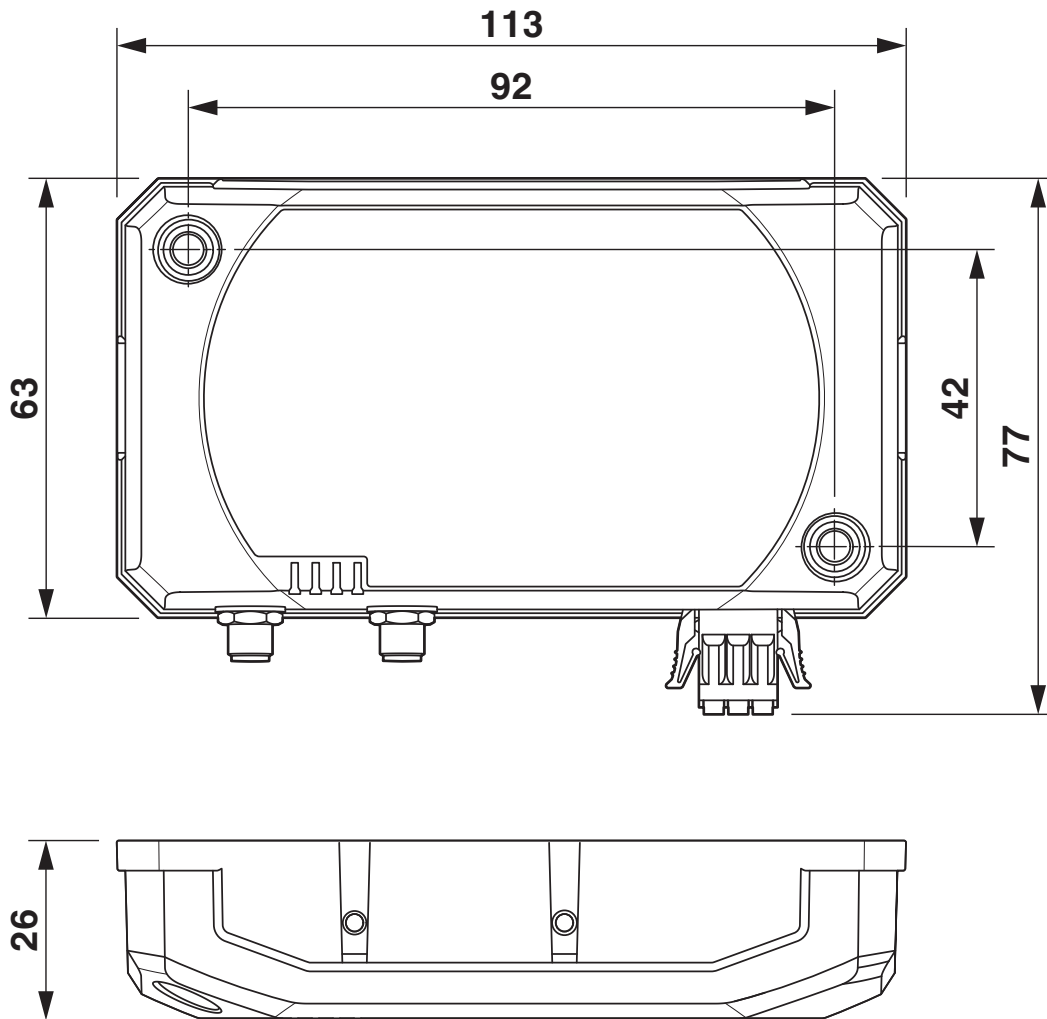

FL WLAN 2011 - Wireless module



1119248

<https://www.phoenixcontact.com/us/products/1119248>

Approvals

To download certificates, visit the product detail page: <https://www.phoenixcontact.com/us/products/1119248>



cULus Listed

Approval ID: E238705

FCC

Approval ID: YG3-SXPCEAN2



IECEX

Approval ID: IECEX ULD 21.0003X



cULus Listed

Approval ID: E366272

FL WLAN 2011 - Wireless module



1119248

<https://www.phoenixcontact.com/us/products/1119248>

Classifications

ECLASS

ECLASS-13.0	19170501
ECLASS-15.0	19170501

ETIM

ETIM 10.0	EC000816
-----------	----------

UNSPSC

UNSPSC 21.0	43222600
-------------	----------

1119248

<https://www.phoenixcontact.com/us/products/1119248>

Environmental product compliance

EU RoHS

Fulfills EU RoHS substance requirements	Yes
Exemption	6(c), 7(a), 7(c)-I

China RoHS

Environment friendly use period (EFUP)	EFUP-50
	An article-related China RoHS declaration table can be found in the download area for the respective article under "Manufacturer declaration". For all articles with EFUP-E, no China RoHS declaration table issued and required.

EU REACH SVHC

REACH candidate substance (CAS No.)	Lead(CAS: 7439-92-1)
	6,6'-di-tert-butyl-2,2'-methylenedi-p-cresol(CAS: 119-47-1)
	2,2',6,6'-tetrabromo-4,4'-isopropylidenediphenol(CAS: 79-94-7)
	2-(2H-benzotriazol-2-yl)-4-(1,1,3,3-tetramethylbutyl)phenol (UV-329)(CAS: 3147-75-9)

Phoenix Contact 2026 © - all rights reserved
<https://www.phoenixcontact.com>

Phoenix Contact USA
 586 Fulling Mill Road
 Middletown, PA 17057, United States
 (+717) 944-1300
info@phoenixcon.com