

FL TIMESERVER NTP - Wireless module



1107132

<https://www.phoenixcontact.com/us/products/1107132>

Please be informed that the data shown in this PDF document is generated from our online catalog. Please find the complete data in the user documentation. Our general terms of use for downloads are valid.



GNSS receiver, NTP and NTS time server (Network Time Protocol, Network Time Security) for Ethernet networks, receives time, date, and location via GPS, Galileo, GLONASS, and BeiDou, supply via PoE (af) or 24 V DC, integrated antenna, IP68 housing

Your advantages

- High availability thanks to a range of different satellite systems
- Automatic switching between GPS, Galileo, GLONASS, and BeiDou
- Robust IP68 housing with integrated antenna for easy installation outside the control cabinet
- Fast, inexpensive connection with just one Power over Ethernet cable
- Precise position determination via web-based management, SNMP, NMEA, or JSON streaming
- Extended temperature range of -40 °C ... +70 °C
- Highest level of cybersecurity with NTS (Network Time Security)



Commercial data

Item number	1107132
Packing unit	1 pc
Minimum order quantity	1 pc
Sales key	DN26
Product key	DNC324
GTIN	4063151006143
Weight per piece (including packing)	353.8 g
Weight per piece (excluding packing)	349.5 g
Customs tariff number	85176200
Country of origin	DE

Technical data

Product properties

Product type	Wireless element
Operating mode	NTP server (NTPv4) stratum 1
MTBF	60 Years (SN 29500 standard, temperature 40°C, operating cycle 100%)
	168 Years (SN 29500 standard, temperature 40°C, operating cycle 34.25%)
	316 Years (SN 29500 standard, temperature 25°C, operating cycle 21%)

Electrical properties

Maximum power dissipation for nominal condition	2.5 W
---	-------

General

Response time	≤ 2 ms (NTP, dependent on Ethernet network and available network capacity)
	1 s (Polling rate of NMEA position data via TCP)
Switch-on time	≤ 100 s (Time until sat fix (cold restart, incl. device start))
	~ 40 s (Device start)

Real-time clock

Accuracy realtime clock	<15 seconds/month in offline mode (no GNSS reception or Internet connection, no temperature fluctuations)
	<60 seconds/month in offline mode (no GNSS reception or Internet connection, with temperature fluctuations)

Supply: Module electronics

Connection technology	COMBICON
Connection method	Push-in spring connection
Note on the connection method	Recommended conductor cross-section: 0.75 mm ²
	Recommended ferrule: connection length 10 mm
	Recommended crimping pliers: trapezoidal or square
Designation	1966101 FMC 1,5/ 3-STF-3,5
Number of positions	2
Cross section range AWG	24 ... 16 (Use copper wires rated 75° C (UL))
Supply voltage	24 V DC (SELV)
Supply voltage range	10 V DC ... 30 V DC (SELV)
	Power over Ethernet (PoE IEEE 802.3af or higher)
Current consumption	≤ 104 mA (24 V)
	max. 175 mA (UL, 10 V)
	max. 60 mA (PoE)
Power consumption	≤ 2.5 W

Connection data

1107132

<https://www.phoenixcontact.com/us/products/1107132>

1966101 FMC 1,5/ 3-STF-3,5

Connection method	Push-in spring connection
pluggable	yes
Conductor cross-section, rigid	0.2 mm ² ... 1.5 mm ²
Conductor cross-section, flexible	0.2 mm ² ... 1.5 mm ²
Conductor cross-section, flexible [AWG]	... 16
Conductor cross-section, flexible, with ferrule, with plastic sleeve	0.25 mm ² ... 0.75 mm ²
Conductor cross-section, flexible, with ferrule, without plastic sleeve	0.25 mm ² ... 1.5 mm ²
	0.25 mm ² ... 1.5 mm ²
Conductor cross-section, flexible, with ferrule, with plastic sleeve	0.25 mm ² ... 0.75 mm ²
Stripping length	10 mm

Interfaces

Functions

Configuration	Web-based management
---------------	----------------------

Ethernet (RJ45)

Number of interfaces	1
Connection method	RJ45
Note on the connection method	Auto negotiation and autocrossing
Transmission speed	10/100 Mbps
Transmission physics	Copper
Transmission length	100 m (per segment)
No. of channels	1 (RJ45 port)
Protocols supported	SNTP
	NTP (v1, v2, v3, v4, without authentication)
	NTS (Network Time Security for NTP)
	NMEA 0183 (via TCP)
	HTTP
	HTTPS
	SNMP
	SSH
	DHCP
	VLAN
Telnet	

Wireless

Designation	GNSS (GPS / Galileo / GLONASS / BeiDou)
Antenna connection method	(Internal)
Frequency	1575.42 MHz (GPS, L1C/A)
	1602 MHz +k * 562,5 kHz (GLONASS, L1OF)
	1575.42 MHz (Galileo, E1-B/C)
	1575.42 MHz (BeiDou, B1C)
Accuracy class	CEP ₅₀ = 5 m (Outdoor assembly)

1107132

<https://www.phoenixcontact.com/us/products/1107132>

Dimensions

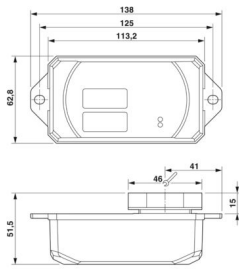
Dimensional drawing	
Width	62.8 mm
Height	36.5 mm
Depth	113.2 mm
Note on dimensions	Outside dimensions

Material specifications

Color (Housing)	black (RAL 9005)
Material (Housing)	Polycarbonate
Material (Base plate)	Die-cast zinc, nickel-plated

Environmental and real-life conditions

Ambient conditions

Ambient temperature (operation)	-40 °C ... 70 °C
Degree of protection	IP68 (Manufacturers declaration, not evaluated by UL) UL/CSA: Enclosure Type Rating 1 (indoor use)
Ambient temperature (storage/transport)	-40 °C ... 85 °C
Permissible humidity (operation)	10 % ... 95 % (non-condensing)
Permissible humidity (storage/transport)	5 % ... 95 % (non-condensing)

Approvals

CE

Certificate	CE-compliant
-------------	--------------

UL, USA/Canada

Identification	UL 61010 Listed
----------------	-----------------

Mounting

Mounting type	Single-hole mounting (outside of control cabinets or other metal housings)
Assembly note	Outside of control cabinets or other metal housings

FL TIMESERVER NTP - Wireless module



1107132

<https://www.phoenixcontact.com/us/products/1107132>

Drawings

Dimensional drawing

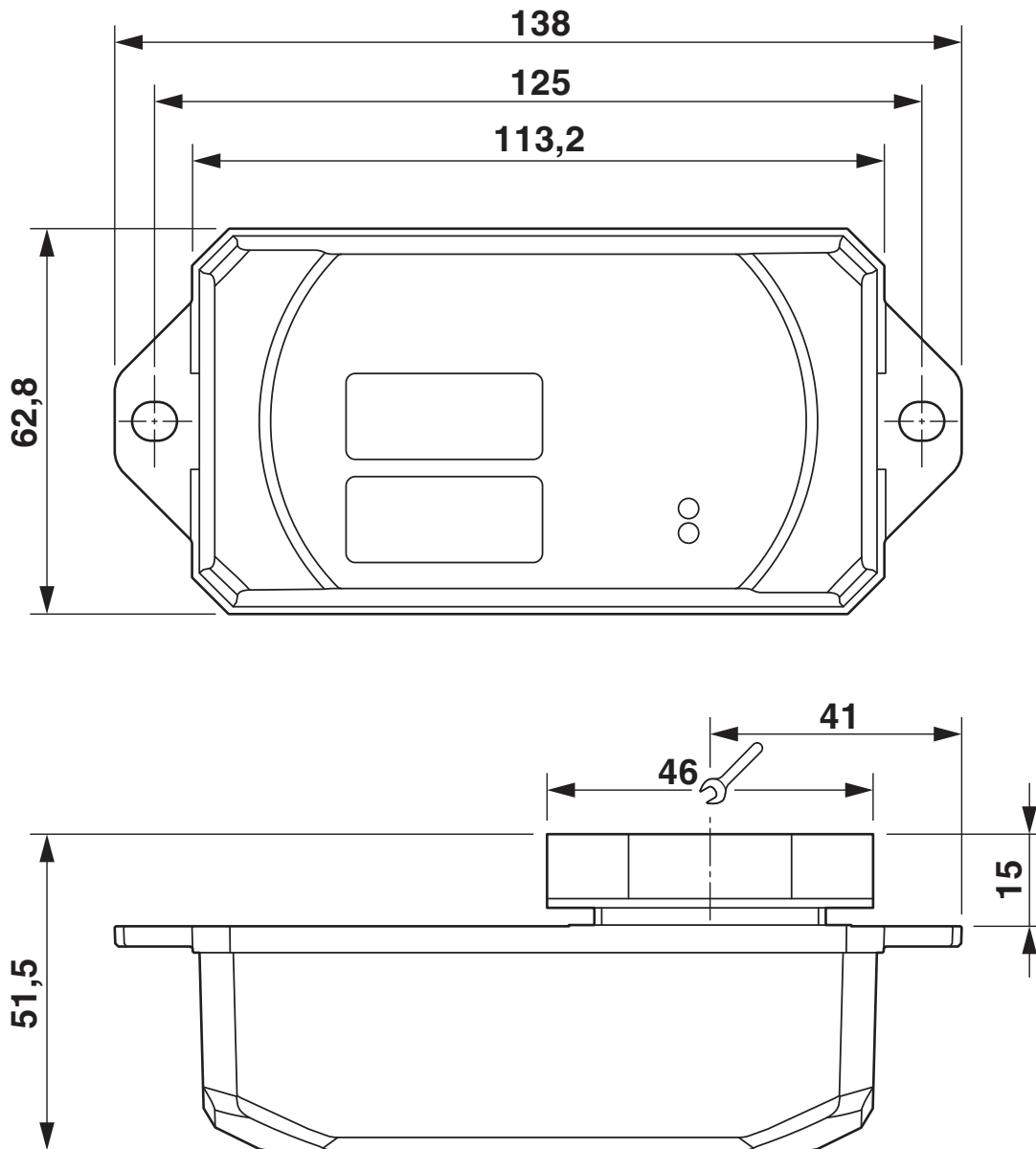

Dimensional drawing

1107132

<https://www.phoenixcontact.com/us/products/1107132>

Dimensional drawing

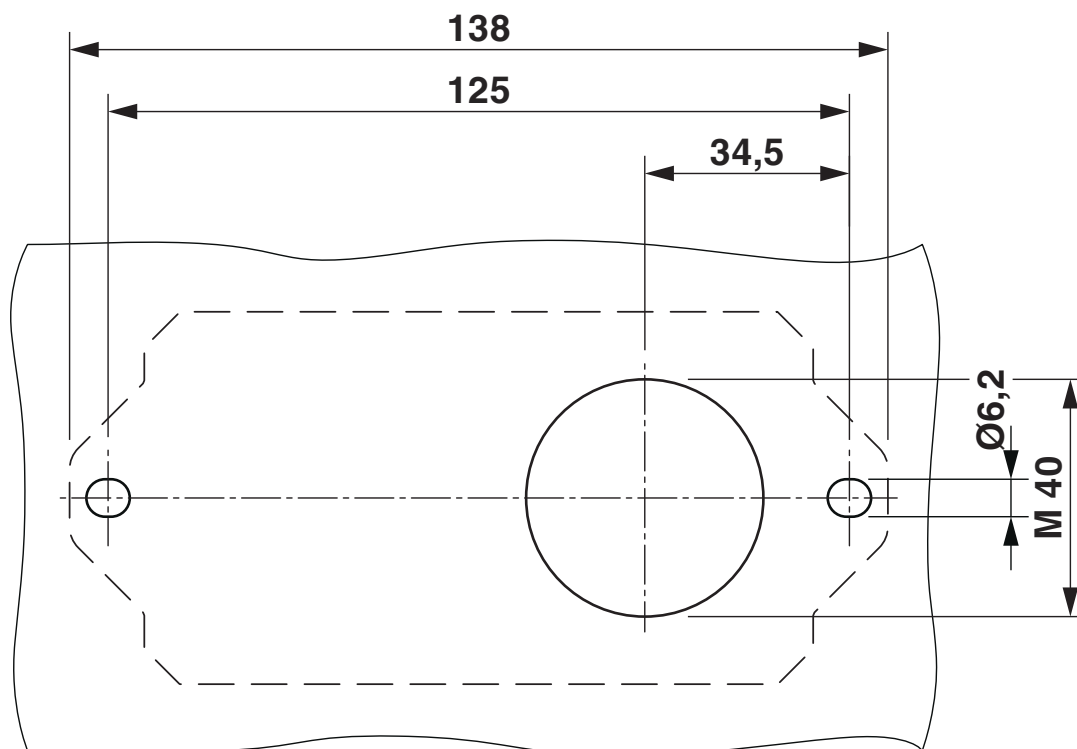

Drilling diagram

FL TIMESERVER NTP - Wireless module

1107132

<https://www.phoenixcontact.com/us/products/1107132>

Application drawing

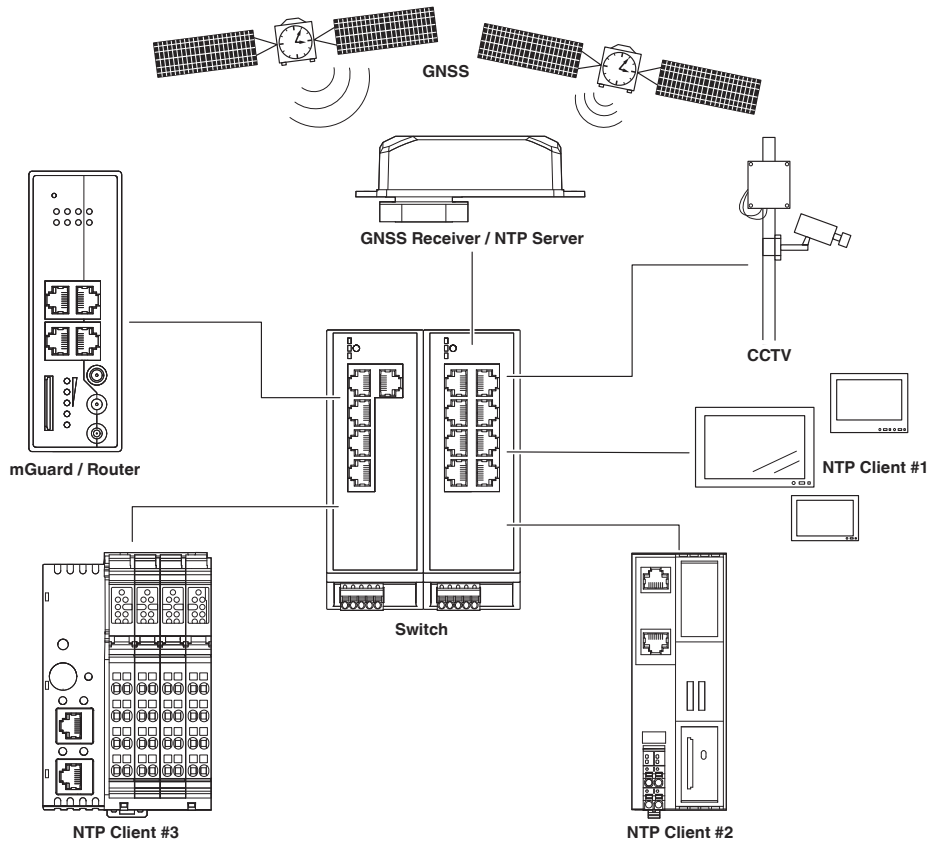

Schematic diagram

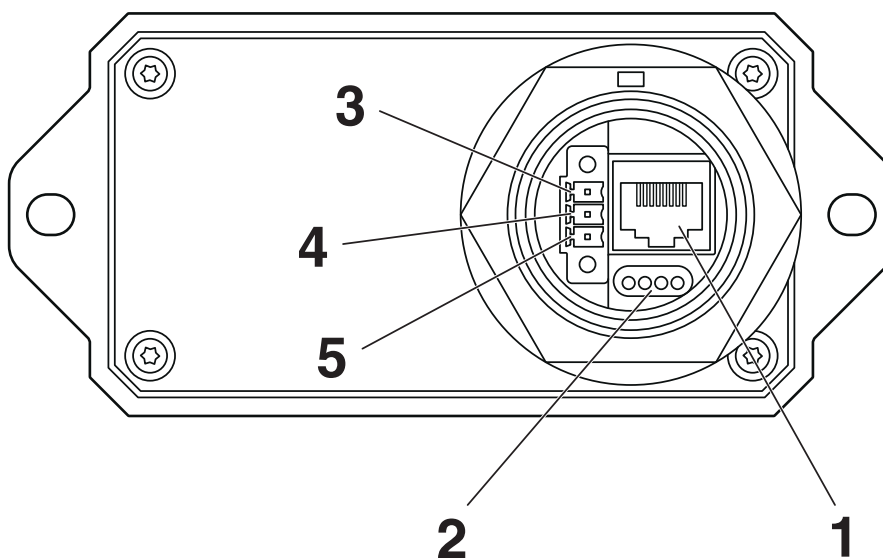

View from below

FL TIMESERVER NTP - Wireless module



1107132

<https://www.phoenixcontact.com/us/products/1107132>

Schematic diagram

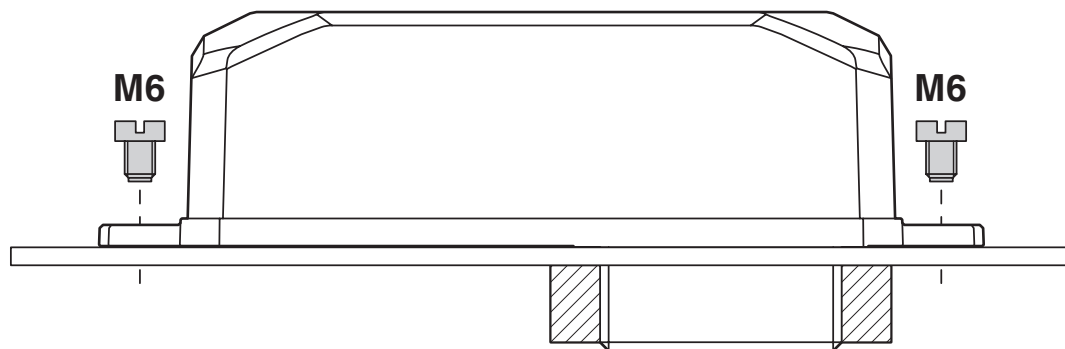

Mounting on the control cabinet

FL TIMESERVER NTP - Wireless module



1107132

<https://www.phoenixcontact.com/us/products/1107132>

Approvals

To download certificates, visit the product detail page: <https://www.phoenixcontact.com/us/products/1107132>



cULus Listed

Approval ID: E238705



cULus Listed

Approval ID: E238705

FL TIMESERVER NTP - Wireless module



1107132

<https://www.phoenixcontact.com/us/products/1107132>

Classifications

ECLASS

ECLASS-13.0	19179090
ECLASS-15.0	19179090

ETIM

ETIM 10.0	EC002608
-----------	----------

UNSPSC

UNSPSC 21.0	43222600
-------------	----------

1107132

<https://www.phoenixcontact.com/us/products/1107132>

Environmental product compliance

EU RoHS

Fulfills EU RoHS substance requirements	Yes, No exemptions
---	--------------------

China RoHS

Environment friendly use period (EFUP)	EFUP-E
	No hazardous substances above the limits

EU REACH SVHC

REACH candidate substance (CAS No.)	2-(2H-benzotriazol-2-yl)-4-(1,1,3,3-tetramethylbutyl)phenol (UV-329)(CAS: 3147-75-9)
-------------------------------------	--

EF3.1 Climate Change

CO2e kg	20.692 kg CO2e
---------	----------------

Phoenix Contact 2026 © - all rights reserved
<https://www.phoenixcontact.com>

Phoenix Contact USA
586 Fulling Mill Road
Middletown, PA 17057, United States
(+717) 944-1300
info@phoenixcon.com