

FL SWITCH 2608 - Industrial Ethernet Switch



1106500

<https://www.phoenixcontact.com/us/products/1106500>

Please be informed that the data shown in this PDF document is generated from our online catalog. Please find the complete data in the user documentation. Our general terms of use for downloads are valid.



Managed Switch 2000 series, 8 M12 ports 10/100 Mbps, degree of protection: IP65/IP66/IP67, Ambient temperature (operation): -40 °C ... 70 °C, Supply voltage range: 9 V DC ... 57 V DC, PROFINET Conformance Class B, Extended temperature range, Development process certified in accordance with IEC 62443-4-1, Product certified in accordance with IEC 62443-4-2

Your advantages

- Robust IP67 housing
- Easy panel mounting



Commercial data

Item number	1106500
Packing unit	1 pc
Minimum order quantity	1 pc
Sales key	DN17
Product key	DNN126
GTIN	4063151002732
Weight per piece (including packing)	1,383 g
Weight per piece (excluding packing)	1,400 g
Customs tariff number	85176200
Country of origin	DE

FL SWITCH 2608 - Industrial Ethernet Switch



1106500

<https://www.phoenixcontact.com/us/products/1106500>

Technical data

Dimensions

Dimensional drawing	
Width	60 mm
Height	226 mm
Depth	46 mm

Material specifications

Color (Housing)	nickel color
Housing material	Die-cast zinc

Mounting

Mounting type	Panel mounting
---------------	----------------

Interfaces

Ethernet

Connection method	M12 connector, D-coded
Note on the connection method	Auto negotiation and autocrossing
Transmission speed	10/100 Mbps
Transmission physics	Copper
Transmission length	100 m (per segment)
Signal LEDs	Data receive, link status
No. of channels	8 (M12 ports)

Product properties

Product type	Switch
Product family	Managed Switch 2000
Type	Stand-alone
MTTF	461.15 Years (SN 29500 standard, temperature 25°C, operating cycle 21%)
	149.69 Years (SN 29500 standard, temperature 40°C, operating cycle 34.25%)
	19.78 Years (SN 29500 standard, temperature 70°C, operating cycle 100%)
Special properties	Extended temperature range
	Development process certified in accordance with IEC 62443-4-1
	Product certified in accordance with IEC 62443-4-2

FL SWITCH 2608 - Industrial Ethernet Switch



1106500

<https://www.phoenixcontact.com/us/products/1106500>

Signal delay	≥ 6.5 μs (Store and Forward mode, 10/100 Mbps, depending on the frame size)
Insulation characteristics	
Protection class	III (VDE 0106)
Switch functions	
Diagnostic functions	RMON History
	LLDP (Link Layer Discovery Protocol)
	SNMP-Traps
	N:1-Portmirroring
	ACD (Address Conflict Detection)
	SysLog
	CRC-Surveillance
Basic functions	Store-and-forward switch, complies with IEEE 802.3
PROFINET conformance class	Conformance Class B
PROFINET device function	PROFINET device
	Fast Startup
Filter functions	Quality of Service (8 priority classes)
	Class of Service
	DiffServ/DSCP
	Port-Priorisierung
	VLAN (up to 32 VLANs)
	IGMP Snooping/Querier (v1/v2)
	Auto-Query-Port
	Extended Multicast Filtering
IP parameterization	DHCP client
	DHCP Option 82 (Relay Agent)
	DHCP server (pool-based, port-based)
	BootP
	DCP (Discovery and Configuration Protocol)
MAC address table	8k
Management	Web-based management (HTTP/HTTPS)
	Role-based user management (LDAP, RADIUS)
	SNMPv1/v2/v3
	Command Line Interface (Telnet, SSH)
Redundancy	MRP (Media Redundancy Protocol)
	RSTP (Rapid Spanning Tree Protocol)
	FRD (Fast Ring Detection)
	Large Tree Support
	LACP (Link Aggregation Control Protocol)
	PROFINET S2 system redundancy
Status and diagnostic indicators	LEDs: US1, US2 (power supply), Fail, 2 LEDs per Ethernet port (Link/Activity and Speed)
Additional functions	Transmission of MMS and GOOSE (IEC 61850-8-1)

FL SWITCH 2608 - Industrial Ethernet Switch



1106500

<https://www.phoenixcontact.com/us/products/1106500>

	Transmission of Modbus/TCP
Time synchronization	SNTP (Simple Network Time Protocol)
Security functions	
Port security	MAC-based, RADIUS (IEEE 802.1X), MAC Authentication Bypass
Basic functions	Store-and-forward switch, complies with IEEE 802.3

Electrical properties

Current consumption	180 mA
Local diagnostics	US1/2 Supply voltage US1, US2 Green LED
	FAIL Div. LED red
	LINK Link status Green LED
Maximum power dissipation for nominal condition	4.68 W ($U_S = \min$, $T_{amb} = \max$)
Test section	24 V supply / functional ground 500 V DC 1 min
	Ethernet interface/all other potentials 2.25 kV DC 1 min
Transmission medium	Copper

Supply

Supply voltage (DC)	24 V DC (redundant)
Supply voltage range	9 V DC ... 57 V DC
Residual ripple	3.6 V _{PP} (within the permitted voltage range)
Max. current consumption	0.52 A ($U_S = \min$, $T_{amb} = \max$)
Typical current consumption	180 mA (at $U_S = 24$ V DC and 25 °C ambient temperature)
Current consumption	180 mA

Connection data

Connection method	M12 connector, A-coded
-------------------	------------------------

Environmental and real-life conditions

Ambient conditions

Degree of protection	IP65
	IP66
	IP67
Ambient temperature (operation)	-40 °C ... 70 °C
Ambient temperature (storage/transport)	-40 °C ... 85 °C
Permissible humidity (operation)	5 % ... 95 %
Permissible humidity (storage/transport)	5 % ... 95 %
Shock (operation)	30g (EN 60068-2-27)
Vibration (operation)	in acc. with IEC 60068-2-6: 5g, 150 Hz
Air pressure (operation)	79 kPa ... 108 kPa up to 2000 m above mean sea level (Without derating)
Air pressure (storage/transport)	79 kPa ... 108 kPa up to 2000 m above mean sea level (Without derating)

Standards and regulations

FL SWITCH 2608 - Industrial Ethernet Switch



1106500

<https://www.phoenixcontact.com/us/products/1106500>

Free from substances that could impair the application of coating	Yes
---	-----

EMC data

Electromagnetic compatibility	Conformance with EMC Directive 2014/30/EU
Conformance with EMC directives	EN 61000-6-2 EN 61000-4-2 (ESD) Criterion B
	EN 61000-6-2 EN 61000-4-3 (electromagnetic fields) Criterion A
	EN 61000-6-2 EN 61000-4-4 (EFT burst) Criterion A
	EN 61000-6-2 EN 61000-4-5 (surge) Criterion B
	EN 61000-6-2 EN 61000-4-6 (line noise immunity) Criterion A
	EN 61000-6-3 (conducted emissions) Class B
Noise immunity	EN 61000-6-2

Noise emission

Standards/regulations	EN 61000-6-3
-----------------------	--------------

System properties

Functionality

Basic functions	Store-and-forward switch, complies with IEEE 802.3
-----------------	--

Signaling

Status display	LEDs: US1, US2 (power supply), Fail, 2 LEDs per Ethernet port (Link/Activity and Speed)
----------------	---

FL SWITCH 2608 - Industrial Ethernet Switch



1106500

<https://www.phoenixcontact.com/us/products/1106500>

Drawings

Dimensional drawing

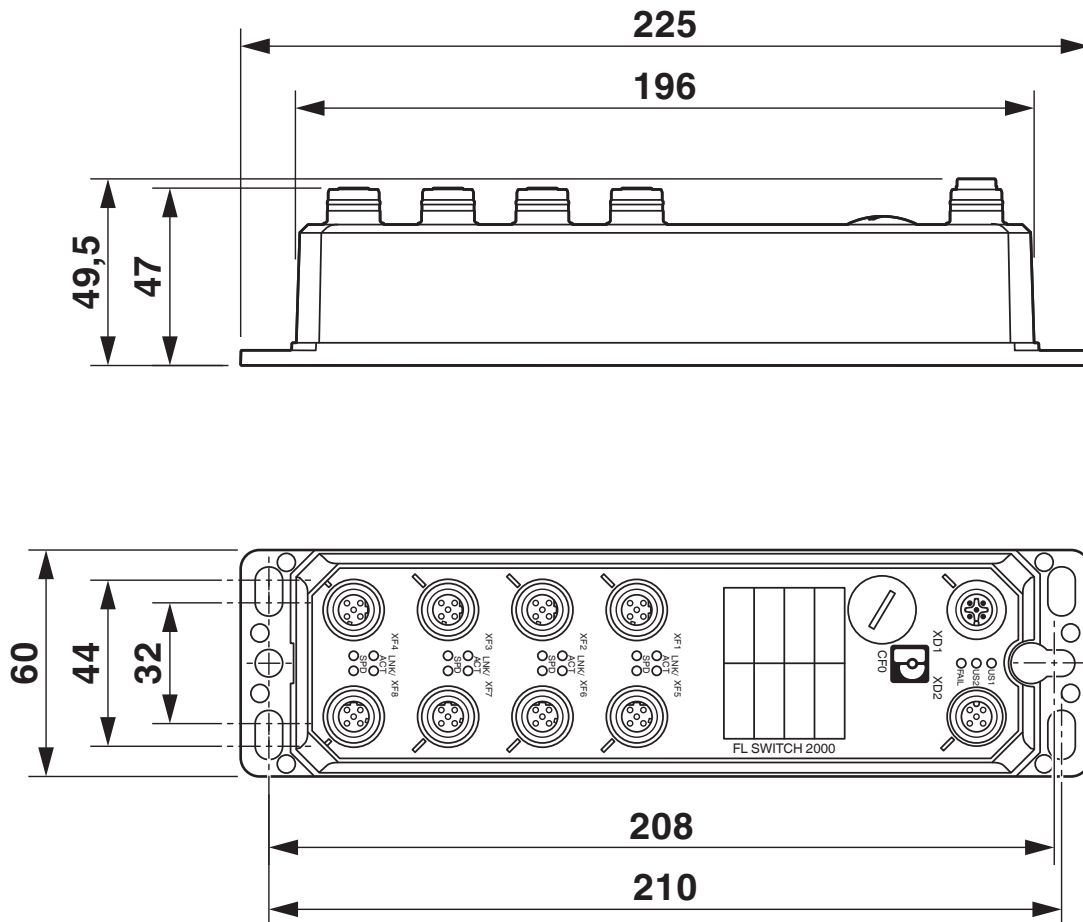

FL SWITCH 2608 - Industrial Ethernet Switch

1106500

<https://www.phoenixcontact.com/us/products/1106500>

Schematic diagram



Connection of the supply voltage

PIN 1 Us1

PIN 2 GND

Pin 3 GND

Pin 4 Us2

Pin 5 functional ground

1106500

<https://www.phoenixcontact.com/us/products/1106500>

Schematic diagram



Assignment of the LAN socket

- Pin 1 Transmit +
- Pin 2 Receive +
- Pin 3 Transmit -
- Pin 4 Receive -

FL SWITCH 2608 - Industrial Ethernet Switch



1106500

<https://www.phoenixcontact.com/us/products/1106500>

Approvals

To download certificates, visit the product detail page: <https://www.phoenixcontact.com/us/products/1106500>



cULus Listed

Approval ID: E238705

Cybersecurity Certificate

Approval ID: 968 CSP 1043.00 25

FL SWITCH 2608 - Industrial Ethernet Switch



1106500

<https://www.phoenixcontact.com/us/products/1106500>

Classifications

ECLASS

ECLASS-13.0	19170401
ECLASS-15.0	19170401

ETIM

ETIM 10.0	EC000734
-----------	----------

UNSPSC

UNSPSC 21.0	43222600
-------------	----------

FL SWITCH 2608 - Industrial Ethernet Switch



1106500

<https://www.phoenixcontact.com/us/products/1106500>

Environmental product compliance

EU RoHS

Fulfills EU RoHS substance requirements	Yes
Exemption	6(c), 7(a), 7(c)-I

China RoHS

Environment friendly use period (EFUP)	EFUP-50
	An article-related China RoHS declaration table can be found in the download area for the respective article under "Manufacturer declaration". For all articles with EFUP-E, no China RoHS declaration table issued and required.

EU REACH SVHC

REACH candidate substance (CAS No.)	Lead(CAS: 7439-92-1)
SCIP	b0ce2b10-b9c1-43c6-96ea-939e3acac4e0

Phoenix Contact 2026 © - all rights reserved

<https://www.phoenixcontact.com>

Phoenix Contact USA
586 Fulling Mill Road
Middletown, PA 17057, United States
(+717) 944-1300
info@phoenixcon.com