

# SOL-SC-1ST-0-DC-1MPPT-2000 - String combiner box (SCB)



1105827

<https://www.phoenixcontact.com/us/products/1105827>

Please be informed that the data shown in this PDF document is generated from our online catalog. Please find the complete data in the user documentation. Our general terms of use for downloads are valid.



String combiner box (SCB); MPP voltage: 1000 V DC; number of strings: 1; number of supported MPP trackers: 1; surge protection: T2; equipment: without special equipment; type of cable entry: Cable gland

## Product description

The Solarline string combiner boxes (SCBs) are used in both small rooftop systems and large ground-mounted systems. The main tasks of the SCBs are the surge protection of the photovoltaic system, collecting strings (if necessary), and looping through the protective equipotential bonding conductor for the local equipotential bonding.

Further functions are optional and depend on the equipment.

Examples of optional functions include protecting the strings with string fuses and disconnecting the strings via DC switch disconnectors or DC fire department switches.

You can determine the full scope of functions of the SCB from its item designation (see the application note for the type key of the SCB, which can be downloaded in the "Downloads" area).

## Your advantages

- Fast installation and startup
- Standard-compliant switchgear and controlgear assembly, thanks to use of DIN EN 61439
- Large portfolio of string combiner boxes in stock
- Application-oriented consultation



## Commercial data

Item number	1105827
Packing unit	1 pc
Minimum order quantity	1 pc
Product key	DTHTAA

# SOL-SC-1ST-0-DC-1MPPT-2000 - String combiner box (SCB)



1105827

<https://www.phoenixcontact.com/us/products/1105827>

GTIN	4055626990064
Weight per piece (including packing)	1,356 g
Weight per piece (excluding packing)	1,356 g
Country of origin	DE

# SOL-SC-1ST-0-DC-1MPPT-2000 - String combiner box (SCB)



1105827

<https://www.phoenixcontact.com/us/products/1105827>

## Technical data

### Product properties

Product type	String combiner box (SCB)
Design	without special equipment

### Insulation characteristics

Protection class	II
------------------	----

### Electrical properties

#### General

MPP voltage $U_n$	max. 1000 V DC
Open-circuit voltage $U_{OC}$	max. 1100 V DC
Current per string $I_{max}$	max. 40 A

#### Surge protection

EN type	T2
IEC test classification	T2
Protection level $U_p$	$\leq 3.7$ kV
Total discharge current $I_{Total}$ (8/20) $\mu s$	40 kA
Short-circuit current rating $I_{SCPV}$	40 A

### Input data

#### DC

Number of inputs (Strings)	1 (Per MPP tracker)
Number of supported MPP trackers	1

### Output data

#### DC

Number of outputs (MPP tracker)	1
Number of outputs ( $\pm$ per MPP tracker)	1 (Per MPP tracker)

### Connection data

#### DC input

Type of cable entry	Cable gland
Connection method	Push-in connection
Cable cross-section range	2.5 mm <sup>2</sup> ... 6 mm <sup>2</sup>
External cable diameter	3 mm ... 6.5 mm

#### Lightning protection equipotential bonding & ground conductor

Type of cable entry	Cable gland
Connection method	Screw connection
Cable cross section	2x 16 mm <sup>2</sup>

# SOL-SC-1ST-0-DC-1MPPT-2000 - String combiner box (SCB)



1105827

<https://www.phoenixcontact.com/us/products/1105827>

External cable diameter	2x 6 mm ... 12 mm
-------------------------	-------------------

## DC output

Type of cable entry	Cable gland
Connection method	Push-in connection
Cable cross-section range	2.5 mm <sup>2</sup> ... 6 mm <sup>2</sup>
External cable diameter	3 mm ... 6.5 mm

## Dimensions

### Housing

Width	130 mm
Height	180 mm
Depth	111 mm

## Material specifications

Material Housing	Polycarbonate
Material Cover/door	Polycarbonate (transparent)

## Environmental and real-life conditions

### Ambient conditions

Degree of protection	IP65
Ambient temperature (operation)	-20 °C ... 55 °C

## Standards and regulations

Standard designation	Low-voltage switchgear and controlgear assemblies - Part 2: Power switchgear and controlgear assemblies
Standards/specifications	EN 61439-2

# SOL-SC-1ST-0-DC-1MPPT-2000 - String combiner box (SCB)



1105827

<https://www.phoenixcontact.com/us/products/1105827>

## Drawings

Dimensional drawing

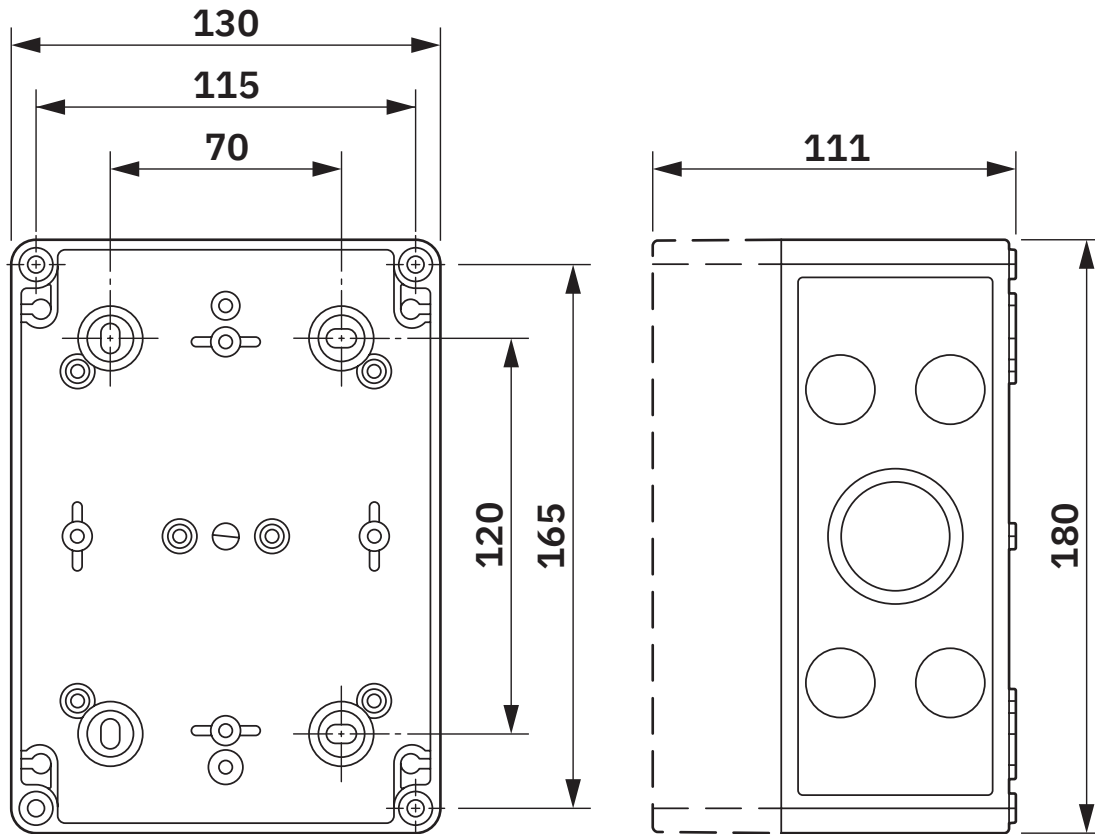

Housing dimensions

# SOL-SC-1ST-0-DC-1MPPT-2000 - String combiner box (SCB)

1105827

<https://www.phoenixcontact.com/us/products/1105827>

Schematic diagram

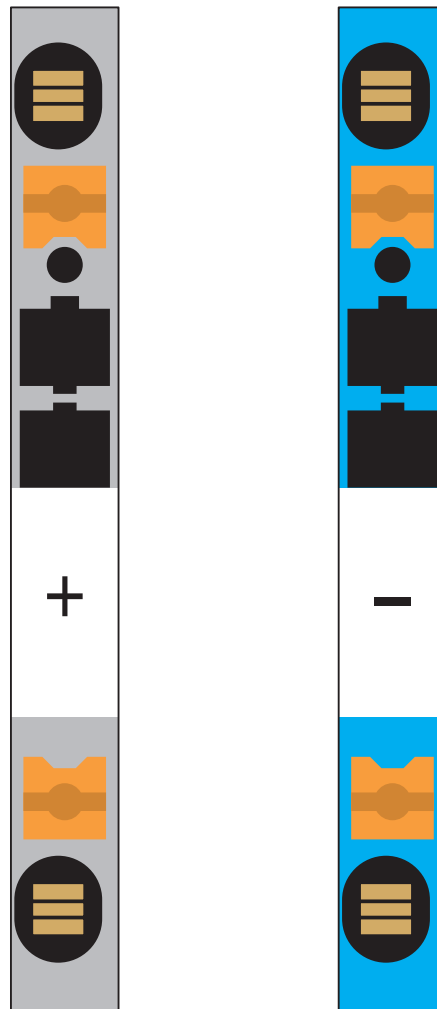

Connection of the PV strings, as well as connection to the inverter

# SOL-SC-1ST-0-DC-1MPPT-2000 - String combiner box (SCB)

1105827

<https://www.phoenixcontact.com/us/products/1105827>

Schematic diagram



Connection of the protective grounding conductor

# SOL-SC-1ST-0-DC-1MPPT-2000 - String combiner box (SCB)

1105827

<https://www.phoenixcontact.com/us/products/1105827>

Schematic diagram



Connection of the protective equipotential bonding conductor

# SOL-SC-1ST-0-DC-1MPPT-2000 - String combiner box (SCB)

1105827

<https://www.phoenixcontact.com/us/products/1105827>

Schematic diagram

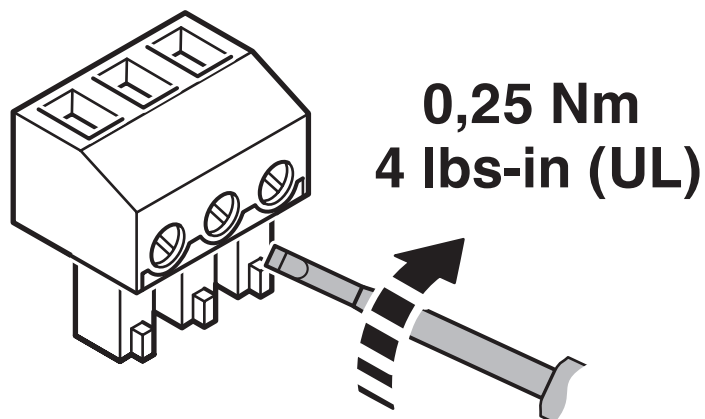

Connection of the remote indication contact on the surge protection

# SOL-SC-1ST-0-DC-1MPPT-2000 - String combiner box (SCB)



1105827

<https://www.phoenixcontact.com/us/products/1105827>

## Classifications

### ECLASS

ECLASS-13.0	27171490
ECLASS-15.0	22570203

### ETIM

ETIM 10.0	EC003857
-----------	----------

### UNSPSC

UNSPSC 21.0	39121100
-------------	----------

# SOL-SC-1ST-0-DC-1MPPT-2000 - String combiner box (SCB)



1105827

<https://www.phoenixcontact.com/us/products/1105827>

## Environmental product compliance

### EU RoHS

Fulfills EU RoHS substance requirements	Yes, No exemptions
---	--------------------

### China RoHS

Environment friendly use period (EFUP)	EFUP-E
	No hazardous substances above the limits

### EU REACH SVHC

REACH candidate substance (CAS No.)	No substance above 0.1 wt%
-------------------------------------	----------------------------

Phoenix Contact 2026 © - all rights reserved  
<https://www.phoenixcontact.com>

Phoenix Contact USA  
586 Fulling Mill Road  
Middletown, PA 17057, United States  
(+717) 944-1300  
[info@phoenixcon.com](mailto:info@phoenixcon.com)