

# PSR-M-GW-ECAT-PI - Data interface



1105131

<https://www.phoenixcontact.com/us/products/1105131>

Please be informed that the data shown in this PDF document is generated from our online catalog. Please find the complete data in the user documentation. Our general terms of use for downloads are valid.



Gateway for connecting a PSR-M base module to a higher-level controller, EtherCAT®, TBUS interface, plug-in Push-in terminal block, TBUS connector included

## Product description

The configurable and individually scalable PSRmodular safety system is a flexible safety solution for monitoring your machine or system. PSRmodular gateways connect a PSR-M basic module to a higher-level controller. This gateway is intended for use with EtherCAT®.

## Your advantages

- Cost-effective safety solution with a high level of adaptability to individual requirements
- Fast startup, thanks to easy hardware and software configuration
- Machine downtimes minimized with comprehensive, easy-to-understand diagnostics
- Low housing width of just 22.6 mm
- Tool-free and time-saving installation thanks to Push-in technology

## Commercial data

Item number	1105131
Packing unit	1 pc
Minimum order quantity	1 pc
Sales key	DN02
Product key	DNA365
GTIN	4055626975184
Weight per piece (including packing)	164.6 g
Weight per piece (excluding packing)	125 g
Customs tariff number	85371098
Country of origin	IT

1105131

<https://www.phoenixcontact.com/us/products/1105131>

## Technical data

### Notes

#### Note on application

Note on application	Only for industrial use
---------------------	-------------------------

### Product properties

Product type	Gateways/Proxies
--------------	------------------

#### Insulation characteristics

Protection class	III (EN 50178)
------------------	----------------

#### Insulation characteristics

Overvoltage category	II
Degree of pollution	2

### Electrical properties

Maximum power dissipation for nominal condition	1.7 W
Nominal operating mode	100% operating factor
Interfaces	DIN rail TBUS for connection to the master module, supplied as standard
Rated surge voltage/insulation	Basic insulation 4 kV

### Supply

Designation	A1/A2
Rated control circuit supply voltage $U_S$	19.2 V DC ... 28.8 V DC
Rated control circuit supply voltage $U_S$	24 V DC -20 % / +20 % (external fuse, typically 4 A)
Inrush current	< 2.2 A ( $\Delta t = 1$ ms at $U_S$ )
Filter time	typ. 5 ms (in the event of voltage dips at $U_S$ )
Protective circuit	Serial protection against polarity reversal Suppressor diode

### Connection data

Connection method	Push-in connection
Stripping length	10 mm

### Interfaces

#### Data: Network interface

Communication protocol	EtherCAT®
Connection method	RJ45 jack
Number of connections	2
Note	IN, OUT

#### Data: Service interface

Connection method	USB 2.0 Hi-Speed
-------------------	------------------

1105131

<https://www.phoenixcontact.com/us/products/1105131>

Number of connections	1
Maximum cable length	3 m

## Signaling

Status display	1 x LED (green), 1 x LED (green, red), 1 x LED (red)
Operating voltage display	1 x LED (green)
Error indication	2 x LED (red)

## Dimensions

Width	22.61 mm
Height	107.74 mm
Depth	113.6 mm

## Material specifications

Color (Housing)	gray (RAL 7042)
Housing material	Polyamide PA non-reinforced

## Environmental and real-life conditions

### Ambient conditions

Degree of protection	IP20
Min. degree of protection of inst. location	IP54
Ambient temperature (operation)	-10 °C ... 55 °C (observe derating)
Ambient temperature (storage/transport)	-20 °C ... 85 °C
Maximum altitude	≤ 2000 m (Above sea level)
Max. permissible humidity (storage/transport)	95 % (non-condensing)
Max. permissible relative humidity (operation)	95 % (non-condensing)
Shock	10g for $\Delta t = 16$ ms (continuous shock, 1000 shocks in each space direction)
Vibration (operation)	10 Hz ... 150 Hz, 2g

## Approvals

### CE

Identification	CE-compliant
----------------	--------------

## Mounting

Mounting type	DIN rail mounting
Mounting position	vertical or horizontal

# PSR-M-GW-ECAT-PI - Data interface



1105131

<https://www.phoenixcontact.com/us/products/1105131>

## Drawings

Application drawing



Block diagram

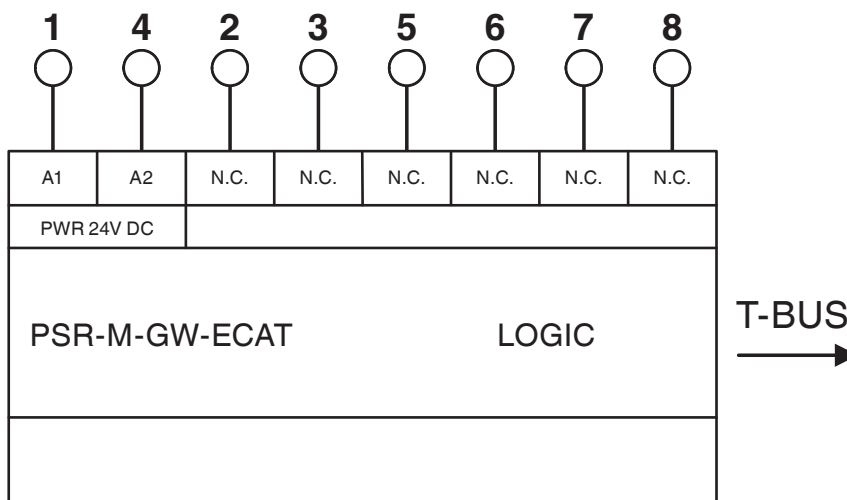

1105131

<https://www.phoenixcontact.com/us/products/1105131>

## Approvals

 To download certificates, visit the product detail page: <https://www.phoenixcontact.com/us/products/1105131>



### **cULus Listed**

Approval ID: E238705



### **Functional Safety**

Approval ID: Z10029429 0013Rev.02

1105131

<https://www.phoenixcontact.com/us/products/1105131>

## Classifications

### ECLASS

ECLASS-13.0	27242608
ECLASS-15.0	27242608

### ETIM

ETIM 10.0	EC001604
-----------	----------

### UNSPSC

UNSPSC 21.0	32151600
-------------	----------

1105131

<https://www.phoenixcontact.com/us/products/1105131>

## Environmental product compliance

### EU RoHS

Fulfills EU RoHS substance requirements	Yes, No exemptions
---	--------------------

### China RoHS

Environment friendly use period (EFUP)	EFUP-E
	No hazardous substances above the limits

### EU REACH SVHC

REACH candidate substance (CAS No.)	No substance above 0.1 wt%
-------------------------------------	----------------------------

Phoenix Contact 2026 © - all rights reserved  
<https://www.phoenixcontact.com>

Phoenix Contact USA  
586 Fulling Mill Road  
Middletown, PA 17057, United States  
(+717) 944-1300  
[info@phoenixcon.com](mailto:info@phoenixcon.com)