

# PSR-M-TBUS2-SC - Extension module



1105097

<https://www.phoenixcontact.com/us/products/1105097>

Please be informed that the data shown in this PDF document is generated from our online catalog. Please find the complete data in the user documentation. Our general terms of use for downloads are valid.



Safe extension module for local bus extension, 2 function channels, TBUS interface, up to SIL 3, Cat. 4/PL e, plug-in screw terminal block, TBUS connector included

## Product description

The configurable and individually scalable PSRmodular safety system is a flexible safety solution for monitoring your machine or system. The extension module is for extending the local bus in the PSRmodular system. Therefore, additional extension modules can be integrated into the system that are at a certain distance from the base station.

## Your advantages

- Cost-effective safety solution with a high level of adaptability to individual requirements
- Fast startup, thanks to easy hardware and software configuration
- Machine downtimes minimized with comprehensive, easy-to-understand diagnostics
- Low housing width of just 22.6 mm



## Commercial data

Item number	1105097
Packing unit	1 pc
Minimum order quantity	1 pc
Sales key	DN02
Product key	DNA362
GTIN	4055626974828
Weight per piece (including packing)	171 g
Weight per piece (excluding packing)	138 g

# PSR-M-TBUS2-SC - Extension module



1105097

<https://www.phoenixcontact.com/us/products/1105097>

Customs tariff number	85371098
Country of origin	IT

## Technical data

### Notes

#### Note on application

Note on application	Only for industrial use
---------------------	-------------------------

### Product properties

Product type	Extension module
Application	Local bus extension

#### Insulation characteristics

Protection class	III
------------------	-----

#### Insulation characteristics

Overvoltage category	II
Degree of pollution	2

### Electrical properties

Maximum power dissipation for nominal condition	0.8 W
Nominal operating mode	100% operating factor
Interfaces	DIN rail TBUS for connection to the master module, supplied as standard
Rated surge voltage/insulation	Basic insulation 4 kV between all current paths and housing

#### Brake to be connected

Connection method	Screw connection
-------------------	------------------

#### Supply

Designation	A1/A2
Rated control circuit supply voltage $U_S$	19.2 V DC ... 28.8 V DC
Rated control circuit supply voltage $U_S$	24 V DC -20 % / +20 % (provide external protection, typically 1 A)
Rated control supply current $I_S$	typ. 33 mA (at $U_S$ )
Power consumption at $U_S$	typ. 0.8 W
Inrush current	max. 8 A ( $\Delta t = 200 \mu s$ at $U_S$ )
Filter time	typ. 20 ms (in the event of voltage dips at $U_S$ )
Protective circuit	Serial protection against polarity reversal Varistor

### Connection data

Connection method	Screw connection
Stripping length	7 mm
Tightening torque	0.5 ... 0.6 Nm
Screw thread	M3

### Interfaces

# PSR-M-TBUS2-SC - Extension module



1105097

<https://www.phoenixcontact.com/us/products/1105097>

## Data: Local bus extension

Communication protocol	RS-485
Connection method	Terminal block
Number of connections	2
Note	Note the requirements for the transmission cable in accordance with the data sheet section "Wiring".

## Signaling

Status display	1 x LED (green)
Operating voltage display	1 x LED (green)
Error indication	2 x LED (red)

## Dimensions

Width	22.61 mm
Height	112.58 mm
Depth	113.6 mm

## Material specifications

Color (Housing)	yellow (RAL 1018)
Housing material	Polyamide PA non-reinforced

## Environmental and real-life conditions

### Ambient conditions

Degree of protection	IP20
Min. degree of protection of inst. location	IP54
Ambient temperature (operation)	-10 °C ... 55 °C (observe derating)
Ambient temperature (storage/transport)	-20 °C ... 85 °C
Maximum altitude	≤ 2000 m (Above sea level)
Max. permissible humidity (storage/transport)	95 % (non-condensing)
Max. permissible relative humidity (operation)	95 % (non-condensing)
Shock	10g for $\Delta t = 16$ ms (continuous shock, 1000 shocks in each space direction)
Vibration (operation)	10 Hz ... 150 Hz, 2g

## Approvals

### CE

Identification	CE-compliant
----------------	--------------

## Mounting

Mounting type	DIN rail mounting
Mounting position	vertical or horizontal

# PSR-M-TBUS2-SC - Extension module



1105097

<https://www.phoenixcontact.com/us/products/1105097>

## Drawings

Application drawing

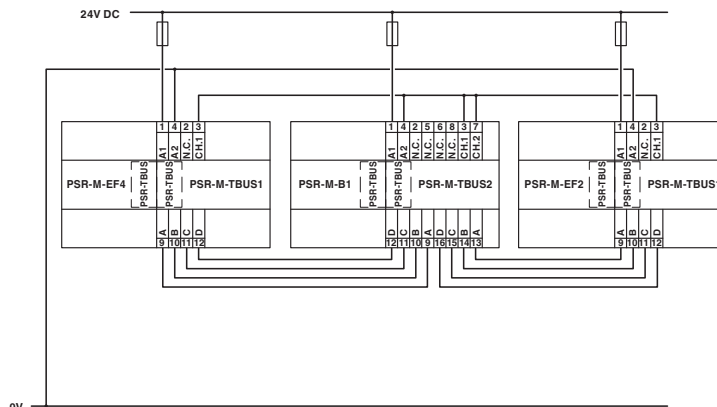

Block diagram

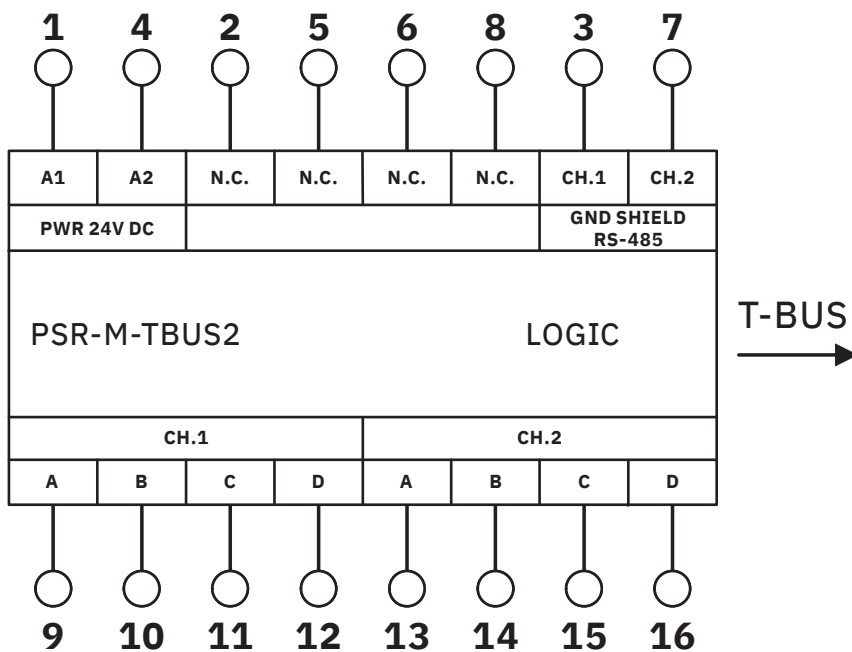

Block diagram

# PSR-M-TBUS2-SC - Extension module



1105097

<https://www.phoenixcontact.com/us/products/1105097>

## Approvals

To download certificates, visit the product detail page: <https://www.phoenixcontact.com/us/products/1105097>



**cULus Listed**

Approval ID: E238705



**Functional Safety**

Approval ID: Z10029429 0013Rev.02

# PSR-M-TBUS2-SC - Extension module



1105097

<https://www.phoenixcontact.com/us/products/1105097>

## Classifications

### ECLASS

ECLASS-13.0	27371819
ECLASS-15.0	27371819

### ETIM

ETIM 10.0	EC001449
-----------	----------

### UNSPSC

UNSPSC 21.0	39122200
-------------	----------

# PSR-M-TBUS2-SC - Extension module



1105097

<https://www.phoenixcontact.com/us/products/1105097>

## Environmental product compliance

### EU RoHS

Fulfills EU RoHS substance requirements	Yes, No exemptions
---	--------------------

### China RoHS

Environment friendly use period (EFUP)	EFUP-E
	No hazardous substances above the limits

### EU REACH SVHC

REACH candidate substance (CAS No.)	No substance above 0.1 wt%
-------------------------------------	----------------------------

### EF3.1 Climate Change

CO2e kg	22.847 kg CO2e
---------	----------------

Phoenix Contact 2026 © - all rights reserved  
<https://www.phoenixcontact.com>

Phoenix Contact USA  
586 Fulling Mill Road  
Middletown, PA 17057, United States  
(+717) 944-1300  
[info@phoenixcon.com](mailto:info@phoenixcon.com)