

# VAL-MS 1500DC-PV/2+V-FM/40 - Type 2 surge arrester



1099548

<https://www.phoenixcontact.com/us/products/1099548>

Please be informed that the data shown in this PDF document is generated from our online catalog. Please find the complete data in the user documentation. Our general terms of use for downloads are valid.



Surge protective device for 2-pos. isolated and grounded 1,500 V DC PV systems, for DIN rail mounting, 3-pos. base element with remote indication contact, three pluggable temperature-monitored protective elements, status message on each plug.

## Your advantages

- Quality proven millions of times over in the widest range of applications
- Rapid installation with bridges, thanks to industry-standard overall width of 1 HP
- Easy testing and insulation measurement, thanks to pluggable protection modules
- Wide range of applications due to various nominal voltages
- High degree of modularity provides individual solutions for every application

## Commercial data

Item number	1099548
Packing unit	40 pc
Minimum order quantity	40 pc
Product key	CL1324
GTIN	4055626949406
Weight per piece (including packing)	358.58 g
Weight per piece (excluding packing)	353 g
Country of origin	DE

# VAL-MS 1500DC-PV/2+V-FM/40 - Type 2 surge arrester



1099548

<https://www.phoenixcontact.com/us/products/1099548>

## Technical data

### Notes

#### General

Note	The device is intended for touch proof installation in a housing. Ensure that there is a gap of at least 8 mm between the active and grounded parts in the connection area.
------	---

### Product properties

Product type	PV arrester
Product family	VALVETRAB MS
IEC test classification	PV II PV T2
EN type	T2
IEC power supply system	DC
Type	DIN rail module, two-section, divisible
Distance between live and grounded parts	8 mm
Environment	Indoor
Installation location of the disconnect device	Internal
Accessibility	Accessible
Connection configuration	Y configuration
End-of-life mode	OCFM (Open-Circuit Failure Mode)
Surge protection fault message	Optical, remote indicator contact
Number of ports	One

#### Insulation characteristics

Overvoltage category	III
Pollution degree	2

### Electrical properties

#### Indicator/remote signaling

Connection name	Remote fault indicator contact
Switching function	Changeover contact
Operating voltage	30 V AC 30 V DC
Operating current	1 A AC 1 A DC

### Connection data

Connection method	Screw connection
Screw thread	M5
Tightening torque	3 Nm (1.5 mm <sup>2</sup> ... 16 mm <sup>2</sup> ) 4.5 Nm (25 mm <sup>2</sup> ... 35 mm <sup>2</sup> )
Stripping length	16 mm

# VAL-MS 1500DC-PV/2+V-FM/40 - Type 2 surge arrester



1099548

<https://www.phoenixcontact.com/us/products/1099548>

Conductor cross-section flexible	1.5 mm <sup>2</sup> ... 25 mm <sup>2</sup>
Conductor cross-section rigid	1.5 mm <sup>2</sup> ... 35 mm <sup>2</sup>
Conductor cross-section AWG	15 ... 2
Connection method	Fork-type cable lug
Conductor cross-section flexible	1.5 mm <sup>2</sup> ... 16 mm <sup>2</sup>

## Remote fault indicator contact

Connection method	Plug-in/screw connection via COMBICON
Screw thread	M2
Tightening torque	0.25 Nm
Stripping length	7 mm
Conductor cross-section flexible	0.14 mm <sup>2</sup> ... 1.5 mm <sup>2</sup>
Conductor cross-section rigid	0.14 mm <sup>2</sup> ... 1.5 mm <sup>2</sup>
Conductor cross-section AWG	28 ... 16

## Dimensions

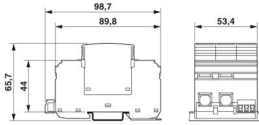
Dimensional drawing	
Width	53.4 mm
Height	98.7 mm
Depth	65.7 mm
Horizontal pitch	3 Div.

## Material specifications

Color	black (RAL 9005)
Flammability rating according to UL 94	V-0
CTI value of material	600
Insulating material	PA 6.6-FR PBT-FR
Material group	I
Housing material	PA 6.6-FR PBT-FR

## Mechanical properties

### Mechanical data

Open side panel	No
-----------------	----

## Protective circuit

Mode of protection	(L+) - (L-)
	(L+) - PE
	(L-) - PE

# VAL-MS 1500DC-PV/2+V-FM/40 - Type 2 surge arrester



1099548

<https://www.phoenixcontact.com/us/products/1099548>

Direction of action	(L+)-PE & (L-)-PE & (L+)-(L-)
Rated load current $I_L$	80 A
Protective conductor current $I_{PE}$	$\leq 350 \mu\text{A DC}$
	$\leq 600 \mu\text{A AC}$
Standby power consumption $P_C$	$\leq 250 \text{ mVA}$
Nominal discharge current $I_n (8/20) \mu\text{s}$	15 kA
Maximum discharge current $I_{\text{max}} (8/20) \mu\text{s}$	30 kA
Total discharge current $I_{\text{Total}} (8/20) \mu\text{s}$	30 kA
Voltage protection level $U_p$	$\leq 5 \text{ kV}$
Residual voltage $U_{\text{res}}$	$\leq 3.8 \text{ kV (at 3 kA)}$
	$\leq 4.1 \text{ kV (at 5 kA)}$
	$\leq 4.4 \text{ kV (at 10 kA)}$
	$\leq 5 \text{ kV (at 15 kA)}$
	$\leq 5.3 \text{ kV (at 20 kA)}$
	$\leq 5.7 \text{ kV (at 30 kA)}$
	$\leq 6 \text{ kV (at 40 kA)}$
Response time $t_A$	$\leq 25 \text{ ns}$

## PV protective circuit

Connection configuration	Y configuration
End-of-life mode	OCFM (Open-Circuit Failure Mode)

## Protective circuit DC voltage side (DC)

Maximum continuous operating voltage $U_{\text{CPV}}$	1500 V DC
Short-circuit current rating $I_{\text{SCPV}}$	2000 A
Open-circuit voltage $U_{\text{OCSTC}}$	$\leq 1250 \text{ V DC}$
Maximum discharge current $I_{\text{max}} (8/20) \mu\text{s}$	30 kA
Response time $t_A$	$\leq 25 \text{ ns}$
Total discharge current $I_{\text{Total}} (8/20) \mu\text{s}$	30 kA
Nominal discharge current $I_n (8/20) \mu\text{s}$	15 kA
Rated load current $I_L$	80 A
Continuous operating current $I_{\text{CPV}}$	$< 350 \mu\text{A}$
Maximum continuous operating voltage $U_{\text{CPV}}$	1500 V DC
Short-circuit current rating $I_{\text{SCPV}}$	2000 A
Residual voltage $U_{\text{res}}$	$\leq 3.8 \text{ kV (at 3 kA)}$
	$\leq 4.1 \text{ kV (at 5 kA)}$
	$\leq 4.4 \text{ kV (at 10 kA)}$
	$\leq 5 \text{ kV (at 15 kA)}$
	$\leq 5.3 \text{ kV (at 20 kA)}$
	$\leq 5.7 \text{ kV (at 30 kA)}$
	$\leq 6 \text{ kV (at 40 kA)}$
Protective conductor current $I_{PE}$	$\leq 350 \mu\text{A DC}$
	$\leq 600 \mu\text{A AC}$
Voltage protection level $U_p$	$\leq 5 \text{ kV}$
Standby power consumption $P_C$	$\leq 250 \text{ mVA}$

# VAL-MS 1500DC-PV/2+V-FM/40 - Type 2 surge arrester



1099548

<https://www.phoenixcontact.com/us/products/1099548>

## Additional technical data

Maximum discharge current $I_{max}$ (8/20) $\mu$ s	40 kA
Nominal discharge current $I_n$ (8/20) $\mu$ s	20 kA (4x (5x $I_n$   120 s)   30 min))

## Environmental and real-life conditions

### Ambient conditions

Degree of protection	IP20 (only when all terminal points are used)
Ambient temperature (operation)	-40 °C ... 85 °C
Ambient temperature (storage/transport)	-40 °C ... 85 °C
Altitude	≤ 3000 m (amsl)
Permissible humidity (operation)	5 % ... 95 %
Shock (operation)	30g (Half-sine / 11 ms / 3x $\pm$ X, $\pm$ Y, $\pm$ Z)
Vibration (operation)	5g (5-500 Hz/2.5 h/XYZ)

## Approvals

### UL specifications

Maximum continuous operating voltage MCOV	1500 V DC
Short-circuit current rating (SCCR)	50 kA
Voltage protection rating VPR	4 kV
Nominal discharge current $I_n$	10 kA
Mode of protection	(DC+) - (DC-) (DC+) - G (DC-) - G
Nominal voltage	1500 V DC
Power distribution system	DC PV
SPD Type	1CA

### UL indicator/remote signaling

Operating voltage	30 V AC
DC operating voltage	30 V DC
AC operating current	1 A AC
DC operating current	1 A DC

### UL connection data

Tightening torque	30 lb <sub>F</sub> -in.
Conductor cross-section AWG	14 ... 2

## Standards and regulations

Standards/specifications	EN 61643-31
Note	2019
Standards/specifications	IEC 61643-31
Note	2018

## Mounting

# VAL-MS 1500DC-PV/2+V-FM/40 - Type 2 surge arrester



1099548

<https://www.phoenixcontact.com/us/products/1099548>

Mounting type

DIN rail: 35 mm

# VAL-MS 1500DC-PV/2+V-FM/40 - Type 2 surge arrester

1099548

<https://www.phoenixcontact.com/us/products/1099548>

## Drawings

Dimensional drawing

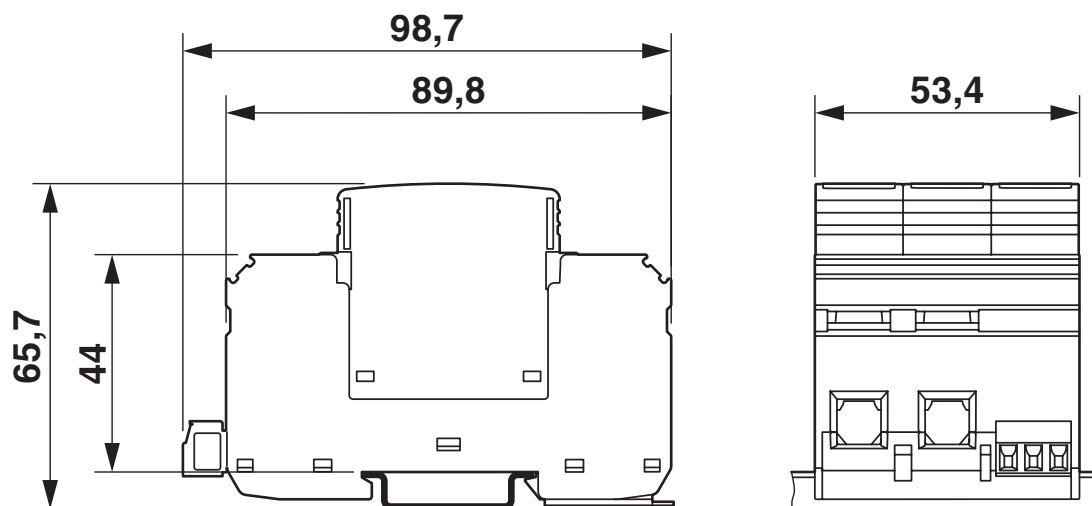

Circuit diagram

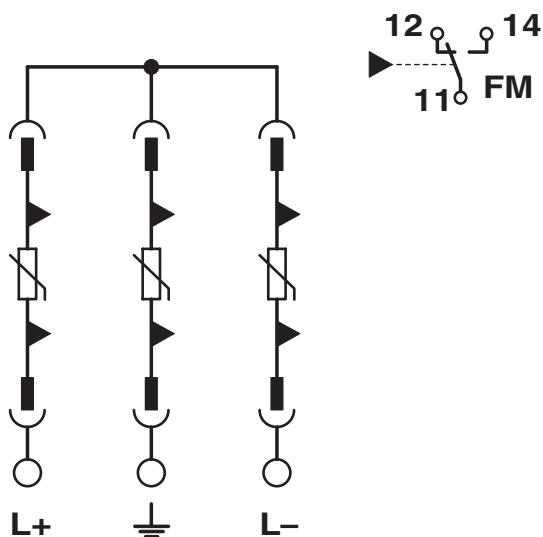

# VAL-MS 1500DC-PV/2+V-FM/40 - Type 2 surge arrester



1099548

<https://www.phoenixcontact.com/us/products/1099548>

## Approvals

To download certificates, visit the product detail page: <https://www.phoenixcontact.com/us/products/1099548>

### UAE-RoHS

Approval ID: 22-09-51250

# VAL-MS 1500DC-PV/2+V-FM/40 - Type 2 surge arrester



1099548

<https://www.phoenixcontact.com/us/products/1099548>

## Classifications

### ECLASS

ECLASS-13.0

27171402

### ETIM

ETIM 9.0

EC000941

### UNSPSC

UNSPSC 21.0

39121620

# VAL-MS 1500DC-PV/2+V-FM/40 - Type 2 surge arrester



1099548

<https://www.phoenixcontact.com/us/products/1099548>

## Environmental product compliance

### EU RoHS

Fulfills EU RoHS substance requirements	Yes, No exemptions
---	--------------------

### China RoHS

Environment friendly use period (EFUP)	EFUP-E
	No hazardous substances above the limits

### EU REACH SVHC

REACH candidate substance (CAS No.)	No substance above 0.1 wt%
-------------------------------------	----------------------------

Phoenix Contact 2026 © - all rights reserved  
<https://www.phoenixcontact.com>

Phoenix Contact USA  
586 Fulling Mill Road  
Middletown, PA 17057, United States  
(+717) 944-1300  
[info@phoenixcon.com](mailto:info@phoenixcon.com)