

# FL SWITCH 2416 PN - Industrial Ethernet Switch



1089150

<https://www.phoenixcontact.com/us/products/1089150>

Please be informed that the data shown in this PDF document is generated from our online catalog. Please find the complete data in the user documentation. Our general terms of use for downloads are valid.



Managed Switch 2000 series, 16 RJ45 ports 10/100 Mbps, degree of protection: IP20, Ambient temperature (operation): -40 °C ... 70 °C, Supply voltage range: 19 V DC ... 32 V DC, PROFINET Conformance Class B, Extended temperature range, PROFINET mode preset, PROFINET status LEDs, Development process certified in accordance with IEC 62443-4-1, Product certified in accordance with IEC 62443-4-2

## Your advantages

- MRP (client and manager)
- VLANs
- DHCP client, DHCP server (pool-based and port-based), DHCP option 82
- RSTP
- Ambient temperature -40 °C ... 70 °C
- Configuration memory
- Web-based management, SNMP
- PROFINET mode preset

## Commercial data

Item number	1089150
Packing unit	1 pc
Minimum order quantity	1 pc
Sales key	DN17
Product key	DNN122
GTIN	4055626893273
Weight per piece (including packing)	1,250 g
Weight per piece (excluding packing)	1,035 g
Customs tariff number	85176200
Country of origin	DE

# FL SWITCH 2416 PN - Industrial Ethernet Switch



1089150

<https://www.phoenixcontact.com/us/products/1089150>

## Technical data

### Dimensions

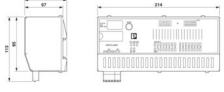
Dimensional drawing	
Width	214 mm
Height	113 mm
Depth	67 mm

### Notes

General	Support by phone or on-site (fee is charged)
Note on application	
Note on application	Only for industrial use

### Material specifications

Material base plate	Die-cast aluminum, corrosion-resistant
Housing material	Stainless steel 1.4301

### Mounting

Mounting type	DIN rail mounting
---------------	-------------------

### Interfaces

#### Ethernet (RJ45)

Connection method	RJ45
Note on the connection method	Auto negotiation and autocrossing
Transmission speed	10/100 Mbps
Transmission physics	Copper
Transmission length	100 m (per segment)
Signal LEDs	Data receive, link status
No. of channels	16 (RJ45 ports)

### Product properties

Product type	Switch
Product family	Managed Switch 2000
Type	Block design
MTTF	238.46 Years (SN 29500 standard, temperature 25°C, operating cycle 21%)
	137.07 Years (SN 29500 standard, temperature 40°C, operating cycle 34.25%)
	21.04 Years (SN 29500 standard, temperature 70°C, operating cycle 100%)
	Extended temperature range

# FL SWITCH 2416 PN - Industrial Ethernet Switch



1089150

<https://www.phoenixcontact.com/us/products/1089150>

Special properties	PROFINET mode preset, PROFINET status LEDs
	Development process certified in accordance with IEC 62443-4-1
	Product certified in accordance with IEC 62443-4-2
Signal delay	≥ 6.5 μs (Store and Forward mode, 10/100 Mbps, depending on the frame size)

## Insulation characteristics

Protection class	III (VDE 0106)
Degree of pollution	2

## Switch functions

Diagnostic functions	RMON History
	LLDP (Link Layer Discovery Protocol)
	SNMP-Traps
	N:1-Portmirroring
	ACD (Address Conflict Detection)
	SysLog
Basic functions	Store-and-forward switch, complies with IEEE 802.3
	Signal contact control voltage
PROFINET conformance class	Conformance Class B
PROFINET device function	PROFINET device
	Fast Startup
Filter functions	Quality of Service (8 priority classes)
	Class of Service
	DiffServ/DSCP
	Port-Priorisierung
	VLAN (up to 32 VLANs)
	IGMP Snooping/Querier (v1/v2)
	Auto-Query-Port
	Extended Multicast Filtering
IP parameterization	DHCP client
	DHCP Option 82 (Relay Agent)
	DHCP server (pool-based, port-based)
	BootP
	DCP (Discovery and Configuration Protocol)
MAC address table	8k
Management	Web-based management (HTTP/HTTPS)
	Role-based user management (LDAP, RADIUS)
	SNMPv1/v2/v3
	Command Line Interface (Telnet, SSH)
Redundancy	MRP (Media Redundancy Protocol)
	RSTP (Rapid Spanning Tree Protocol)
	FRD (Fast Ring Detection)
	Large Tree Support

# FL SWITCH 2416 PN - Industrial Ethernet Switch



1089150

<https://www.phoenixcontact.com/us/products/1089150>

	LACP (Link Aggregation Control Protocol)
	PROFINET S2 system redundancy
Status and diagnostic indicators	LEDs: US1, US2 (power supply), Fail (alarm contact), 2 LEDs per Ethernet port (link/activity and speed), PROFINET status LEDs (BF, SF)
Additional functions	Transmission of MMS and GOOSE (IEC 61850-8-1)
	Transmission of Modbus/TCP
Time synchronization	SNTP (Simple Network Time Protocol)
<b>Security functions</b>	
Port security	MAC-based, RADIUS (IEEE 802.1X), MAC Authentication Bypass
Basic functions	Store-and-forward switch, complies with IEEE 802.3

## Electrical properties

Local diagnostics	US1/2 Supply voltage US1, US2 Green LED
	FAIL Div. LED red
	LNK/ACT Link status Green LED
	SPD Data transmission speed Green LED
	BF Bus errors LED red
	SF Group error LED red
Maximum power dissipation for nominal condition	7.52 W ( $U_S = \max$ , $T_{amb} = \max$ )
Test section	24 V supply / functional ground 500 V DC 1 min
	Ethernet interface/all other potentials 2.25 kV DC 1 min
Transmission medium	Copper

## Supply

Supply voltage (DC)	24 V DC (redundant)
Supply voltage range	19.2 V DC ... 32 V DC
Power supply connection	Via COMBICON, max. conductor cross-section 2.5 mm <sup>2</sup>
Residual ripple	3.6 V <sub>PP</sub> (within the permitted voltage range)
Max. current consumption	390 mA ( $U_S = \min$ , $T_{amb} = \max$ )
Typical current consumption	280 mA (at $U_S = 24$ V DC and 25 °C ambient temperature)

## Function

Signal contact control voltage	typ. 24 V DC
--------------------------------	--------------

## Connection data

Connection method	Push-in spring connection
Note on the connection method	Use only copper connecting cables providing the permitted temperature range (-40 °C ... 75 °C)
pluggable	yes
Conductor cross-section, rigid	0.2 mm <sup>2</sup> ... 1.5 mm <sup>2</sup>
Conductor cross-section, flexible	0.2 mm <sup>2</sup> ... 2.5 mm <sup>2</sup>
Conductor cross-section AWG	24 ... 16
Stripping length	10 mm

1089150

<https://www.phoenixcontact.com/us/products/1089150>

## Environmental and real-life conditions

### Ambient conditions

Degree of protection	IP20
Ambient temperature (operation)	-40 °C ... 70 °C
Ambient temperature (storage/transport)	-40 °C ... 85 °C
Permissible humidity (operation)	10 % ... 95 % (non-condensing)
Permissible humidity (storage/transport)	10 % ... 95 % (non-condensing)
Shock (operation)	30g (EN 60068-2-27)
Vibration (operation)	in acc. with IEC 60068-2-6: 5g, 150 Hz
Air pressure (operation)	79 kPa ... 108 kPa up to 2000 m above mean sea level (Without derating)
Air pressure (storage/transport)	79 kPa ... 108 kPa up to 2000 m above mean sea level (Without derating)

## Standards and regulations

Free from substances that could impair the application of coating	Yes
---	-----

## Approvals

### UL, USA/Canada

Identification	cULus
----------------	-------

### Corrosive gas test

Identification	ISA S71.04.2013 G3 Harsh Group A
----------------	----------------------------------

### Shipbuilding data

Temperature	B
Humidity	B
Vibration	A
EMC	B
Enclosure	Required protection according to the Rules shall be provided upon installation on board

## EMC data

Electromagnetic compatibility	Conformance with EMC Directive 2014/30/EU
Conformance with EMC directives	EN 61000-6-2 EN 61000-4-2 (ESD) Criterion B
	EN 61000-6-2 EN 61000-4-3 (electromagnetic fields) Criterion A
	EN 61000-6-2 EN 61000-4-4 (EFT burst) Criterion A
	EN 61000-6-2 EN 61000-4-5 (surge) Criterion A
	EN 61000-6-2 EN 61000-4-6 (line noise immunity) Criterion A
	EN 61000-6-2 EN 61000-6-4 (interference) Class A
Noise immunity	EN 61000-6-2
	EN 61000-6-4

### Noise emission

Standards/regulations	EN 61000-6-4
-----------------------	--------------

# FL SWITCH 2416 PN - Industrial Ethernet Switch



1089150

<https://www.phoenixcontact.com/us/products/1089150>

## System properties

### Functionality

Basic functions

Store-and-forward switch, complies with IEEE 802.3

### Signaling

Status display

LEDs: US1, US2 (power supply), Fail (alarm contact), 2 LEDs per Ethernet port (link/activity and speed), PROFINET status LEDs (BF, SF)

# FL SWITCH 2416 PN - Industrial Ethernet Switch



1089150

<https://www.phoenixcontact.com/us/products/1089150>

## Drawings

Dimensional drawing

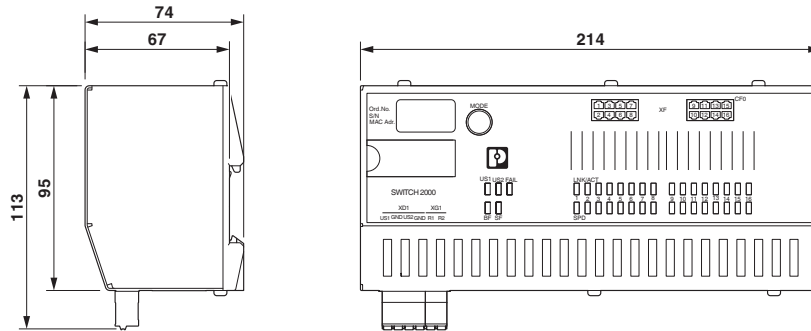

Connection diagram



# FL SWITCH 2416 PN - Industrial Ethernet Switch

1089150

<https://www.phoenixcontact.com/us/products/1089150>



Connection diagram

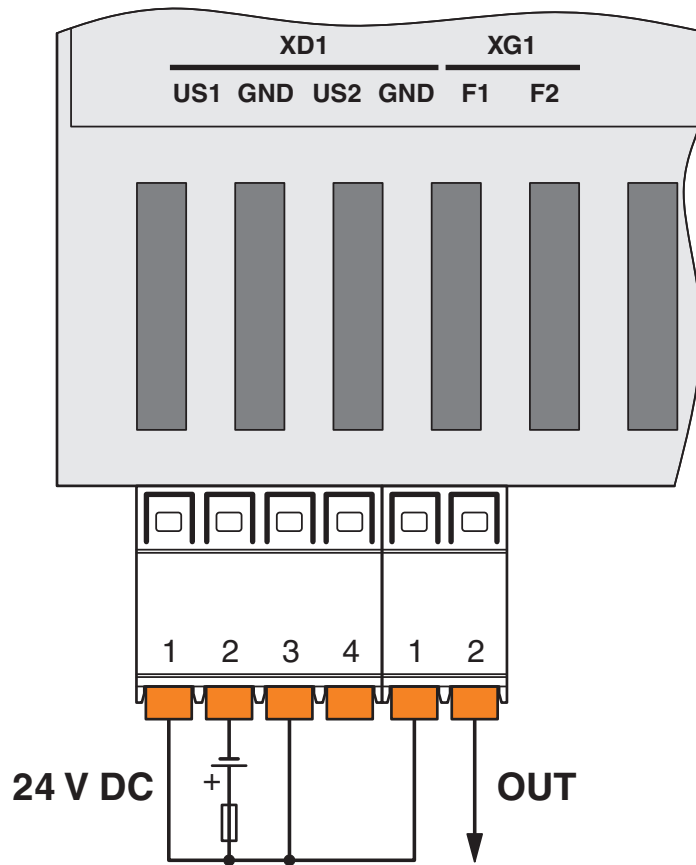

# FL SWITCH 2416 PN - Industrial Ethernet Switch



1089150

<https://www.phoenixcontact.com/us/products/1089150>

## Approvals

To download certificates, visit the product detail page: <https://www.phoenixcontact.com/us/products/1089150>



**DNV GL**

Approval ID: TAA00000YV



**LR**

Approval ID: LR22250919TA



**BV**

Approval ID: 48146\_B1 BV

**BSH**

Approval ID: 1045

**ABS**

Approval ID: 21\_2066186\_1\_PDA



**RINA**

Approval ID: ELE014724XG001



**cULus Listed**

Approval ID: E238705

**PROFINET**

Approval ID: Z12634

**PROFINET**

Approval ID: Z12624-Z12639

# FL SWITCH 2416 PN - Industrial Ethernet Switch



1089150

<https://www.phoenixcontact.com/us/products/1089150>

## Classifications

### ECLASS

ECLASS-13.0	19170401
ECLASS-15.0	19170401

### ETIM

ETIM 10.0	EC000734
-----------	----------

### UNSPSC

UNSPSC 21.0	43222600
-------------	----------

# FL SWITCH 2416 PN - Industrial Ethernet Switch



1089150

<https://www.phoenixcontact.com/us/products/1089150>

## Environmental product compliance

### EU RoHS

Fulfills EU RoHS substance requirements	Yes
Exemption	7(a), 7(c)-I

### China RoHS

Environment friendly use period (EFUP)	EFUP-50
	An article-related China RoHS declaration table can be found in the download area for the respective article under "Manufacturer declaration". For all articles with EFUP-E, no China RoHS declaration table issued and required.

### EU REACH SVHC

REACH candidate substance (CAS No.)	Lead(CAS: 7439-92-1)
-------------------------------------	----------------------

Phoenix Contact 2026 © - all rights reserved  
<https://www.phoenixcontact.com>

Phoenix Contact USA  
586 Fulling Mill Road  
Middletown, PA 17057, United States  
(+717) 944-1300  
[info@phoenixcon.com](mailto:info@phoenixcon.com)