

HC-COM-HHFS-1STM25-EL-AL - Housing



1078592

<https://www.phoenixcontact.com/us/products/1078592>

Please be informed that the data shown in this PDF document is generated from our online catalog. Please find the complete data in the user documentation. Our general terms of use for downloads are valid.



Sleeve housing COM, for single locking latch, material: Die-cast aluminum, salt water resistant, cable outlets: 1, lateral, 1x M25, height: 68 mm, cable gland: none, Standard

Your advantages

- Good shielding in the event of electromagnetic interference

Commercial data

Item number	1078592
Packing unit	1 pc
Minimum order quantity	1 pc
Sales key	BF59
Product key	AF7APP
GTIN	4055626794105
Weight per piece (including packing)	81.8 g
Weight per piece (excluding packing)	81 g
Customs tariff number	76169990
Country of origin	CN

HC-COM-HHFS-1STM25-EL-AL - Housing

1078592

<https://www.phoenixcontact.com/us/products/1078592>

Technical data

Product properties

Product type	Housing with locking latch
Housing type	Sleeve housing
Product family	HC-COM
Application	Standard
Type	COM
No. of cable outlets	1
Type of the screw connection	1x M25
Cable outlet	lateral
Pg screw connection	none

Dimensions

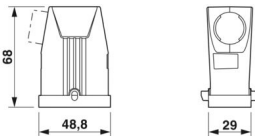
Dimensional drawing	
Width	39 mm
Height	68 mm
Length	48.8 mm

Material specifications

Housing material	Die-cast aluminum, salt water resistant
------------------	---

Mechanical properties

Mechanical data

Type of the screw connection	1x M25
Locking type	Pin

Environmental and real-life conditions

Ambient conditions

Degree of protection	IP66
Impact strength	IK06
Ambient temperature (operation)	-40 °C ... 125 °C

HC-COM-HHFS-1STM25-EL-AL - Housing

1078592

<https://www.phoenixcontact.com/us/products/1078592>



Drawings

Dimensional drawing

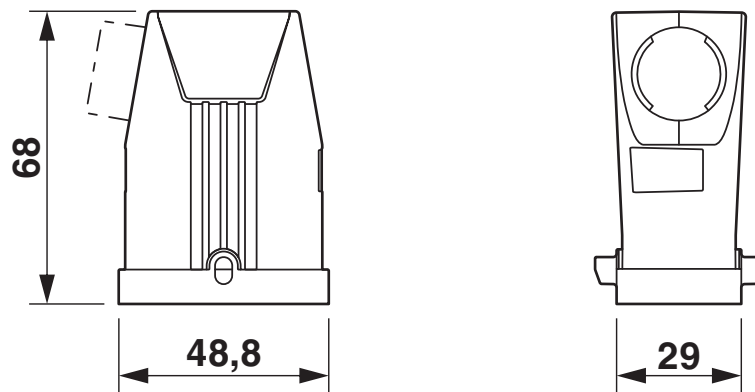

HC-COM-HHFS-1STM25-EL-AL - Housing



1078592

<https://www.phoenixcontact.com/us/products/1078592>

Approvals

To download certificates, visit the product detail page: <https://www.phoenixcontact.com/us/products/1078592>



cUL Recognized
Approval ID: E255026



UL Recognized
Approval ID: E255026

1078592

<https://www.phoenixcontact.com/us/products/1078592>

Classifications

ECLASS

ECLASS-13.0	27440202
ECLASS-15.0	27440202

ETIM

ETIM 10.0	EC000437
-----------	----------

UNSPSC

UNSPSC 21.0	31261500
-------------	----------

1078592

<https://www.phoenixcontact.com/us/products/1078592>

Environmental product compliance

EU RoHS

Fulfills EU RoHS substance requirements	Yes, No exemptions
---	--------------------

China RoHS

Environment friendly use period (EFUP)	EFUP-E
	No hazardous substances above the limits

EU REACH SVHC

REACH candidate substance (CAS No.)	No substance above 0.1 wt%
-------------------------------------	----------------------------

Phoenix Contact 2026 © - all rights reserved
<https://www.phoenixcontact.com>

Phoenix Contact USA
586 Fulling Mill Road
Middletown, PA 17057, United States
(+717) 944-1300
info@phoenixcon.com