

EV-T2HPCC-DC400A-5,0M50ECBK11S - DC charging cable



1052444

<https://www.phoenixcontact.com/us/products/1052444>

Please be informed that the data shown in this PDF document is generated from our online catalog. Please find the complete data in the user documentation. Our general terms of use for downloads are valid.



CHARX connect professional, CCS type 2, HPC DC charging cable, 400 A permanent, 1000 V DC, with cooled vehicle charging connector and cooled cable, cable: 5 m, black, straight, with replaceable mating face frame, with replaceable DC power contacts, with straight panel feed-through, with digital temperature sensors, Liquid cooling, PHOENIX CONTACT logo, IEC 62196-3-1, for charging electric vehicles (EV) with direct current (DC)

Product description

DC charging cable with vehicle charging connector and free cable end for fast charging of electric vehicles (EV) with direct current (DC) via CCS type 2 vehicle charging inlets, for installation at charging stations for e-mobility (EVSE)

Your advantages

- Complete product range
- The right charging cable for every application, from the carport to the charging park
- Ultra-fast HPC charging, with temporary power up to 500 kW
- Convenient handling due to the ergonomic design
- Available with your logo on request - for consistent branding of your charging station
- Developed and produced in accordance with the IATF 16949 automotive standard and ISO 9001
- Additional safety thanks to integrated leakage sensors and a wear indicator in the cable sheath
- Convenient communication interfaces via CAN bus and digital output
- Maintenance-friendly replacement of the mating face frame without draining the coolant
- Integrated strain relief of single-core wires directly in the panel feed-through
- Pre-assembled busbar screw connection for straightforward connection of the customer's busbars or cable lug solutions

Commercial data

Item number	1052444
Packing unit	1 pc
Minimum order quantity	1 pc
Sales key	EM01
Product key	XWBALD
GTIN	4055626675275
Weight per piece (including packing)	22.22 g
Weight per piece (excluding packing)	22.22 g
Customs tariff number	85444290
Country of origin	DE

EV-T2HPCC-DC400A-5,0M50ECBK11S - DC charging cable



1052444

<https://www.phoenixcontact.com/us/products/1052444>

Technical data

Product properties

Product type	DC charging cable
Product family	CHARX connect professional
Type	HPC DC charging cable with cooled vehicle charging connector and cooled cable
Design	with replaceable mating face frame with replaceable DC power contacts with straight panel feed-through with digital temperature sensors Liquid cooling
Charging standard	CCS type 2
Charging mode	Mode 4
Affixed logo	PHOENIX CONTACT logo
Label	8.9 mm x 28.9 mm (customer logo on request)

Electrical properties

Type of signal transmission	Pulse width modulation with modulated Powerline communication in accordance with ISO/IEC 15118 / DIN SPEC 70121
Note on the connection method	Crimp connection, cannot be disconnected
Coding	1500 Ω (between PE and PP)
Temperature monitoring	2x NTC (replaceable, front DC contacts) 2x NTC (DC power wires inside) Pt 1000

Charging power and current (DC charging)

Type of charging current	DC
Charging current	400 A DC
Charging power	400 kW
Rated voltage	1000 V

Pin assignment (Power contacts)

Number	3 (PE, DC+, DC-)
Rated voltage	1000 V DC
Rated current	400 A (up to 40 °C)

Pin assignment (Signal contacts)

Number	2 (CP, PP)
Rated voltage	30 V AC
Rated current	2 A

Temperature sensors (NTC)

Sensor type	NTC
Attachment point	2 sensors for the replaceable front DC contacts

EV-T2HPCC-DC400A-5,0M50ECBK11S - DC charging cable



1052444

<https://www.phoenixcontact.com/us/products/1052444>

	2 sensors for the internal DC power wires
Switch-off temperature	90 °C
Temperature sensors (Pt 1000)	
Sensor type	Pt 1000
Standards/regulations	DIN EN 60751
Attachment point	Sensor in the panel feed-through
Switch-off temperature	90 °C ± 1 K (equivalent to a Pt 1000 value of 1346.5 Ω)
Long-term stability	0.06 % (after 1000 hours at 130 °C)
Recommended measured current	1 mA (1 V at 0°C)
Coefficient	3850 ppm/K
Ambient temperature	-50 °C ... 130 °C (Operation)

Dimensions

Vehicle charging connector

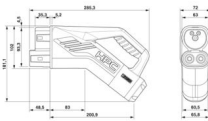
Dimensional drawing	 <p>Make sure that the vehicle charging connector is placed in an appropriate charging connector holder, which ensures a minimum protection rating of IP24 in accordance with IEC 61851-1, for the entire time between charging. To create this charging connector holder, use the dimensions of the vehicle charging connector. Detailed dimensions can also be found in the Download area.</p>
Width	72 mm
Height	181.1 mm
Depth	285.3 mm

Panel feed-through

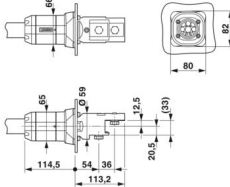
Dimensional drawing	
Width	80 mm
Height	82 mm
Depth	227.69 mm

Material specifications

Color (Housing)	black (9005)
Color (Handle area)	black (9005)
Color (Mating face)	black (9005)

EV-T2HPCC-DC400A-5,0M50ECBK11S - DC charging cable



1052444

<https://www.phoenixcontact.com/us/products/1052444>

Color (Cable)	black (9005)
Color (Panel feed-through)	black (9005)
Material (Vehicle charging connector)	Plastic
Material (Cable outer sheath)	EVM-1 in accordance with EN 50620
Material (Panel feed-through)	Plastic
Material (Contact surface)	Silver
Flammability rating according to UL 94	V0 (Mating face)

Cable/line

Cable length	5 m ±45 mm
Wiring standards/regulations	according to UL 62 (File E515623, Vol 1) according to IEC 62893
Cable weight	max. 1938.00 kg/km
Cable type	straight
Cable structure	5 x 25 mm ² + 7 x 0.75 mm ²
External cable diameter	35.70 mm ±0.4 mm
Outer sheath, material	TPE-U in accordance with IEC 62893-1
Cable resistance	≤ 0.00078 Ω/m (based on a power core, at an ambient temperature of 20°C)
Bending radius	min. 357 mm (10x Ø)

Mechanical properties

Mechanical data

Insertion/withdrawal cycles	> 10000
Insertion force	< 100 N
Withdrawal force	< 100 N

Environmental and real-life conditions

Ambient conditions

Degree of protection (Vehicle charging connector)	IP54 (plugged in; when plugged in and ready to operate, the degree of protection is only ensued if both plug-in components are original products from Phoenix Contact or suitable standard-compliant products)
Degree of protection (Panel feed-through)	IP54
Ambient temperature (operation)	-30 °C ... 40 °C max. 55 °C (Current reduction required, observe the DC contact temperature limit value of 90°C)
Ambient temperature (storage/transport)	-40 °C ... 80 °C
Altitude	5000 m (above sea level)

Standards and regulations

Standards

Standards/regulations	IEC 62196-3-1
-----------------------	---------------

Mounting

EV-T2HPCC-DC400A-5,0M50ECBK11S - DC charging cable



1052444

<https://www.phoenixcontact.com/us/products/1052444>

Mounting type	Panel feed-through	Rear panel mounting
Fixing screws		M5x16

EV-T2HPCC-DC400A-5,0M50ECBK11S - DC charging cable



1052444

<https://www.phoenixcontact.com/us/products/1052444>

Drawings

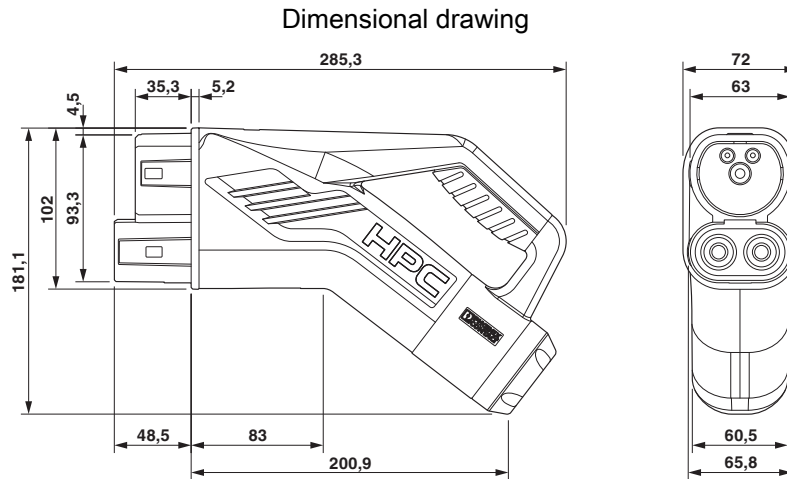

Make sure that the vehicle charging connector is placed in an appropriate charging connector holder, which ensures a minimum protection rating of IP24 in accordance with IEC 61851-1, for the entire time between charging. To create this charging connector holder, use the dimensions of the vehicle charging connector. Detailed dimensions can also be found in the Download area.

EV-T2HPCC-DC400A-5,0M50ECBK11S - DC charging cable



1052444

<https://www.phoenixcontact.com/us/products/1052444>

Dimensional drawing

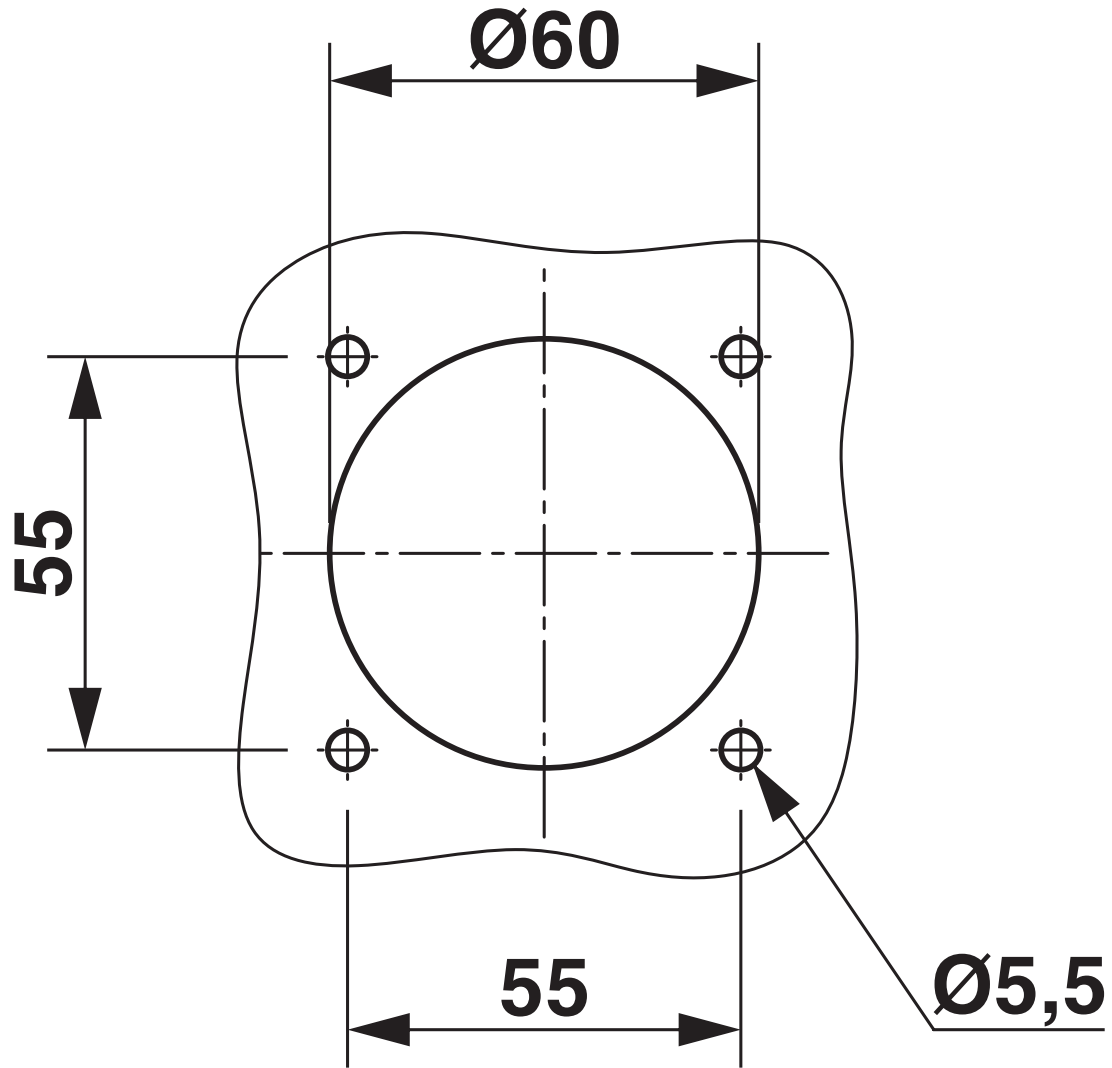

Drill hole spacing

EV-T2HPCC-DC400A-5,0M50ECBK11S - DC charging cable



1052444

<https://www.phoenixcontact.com/us/products/1052444>

Dimensional drawing

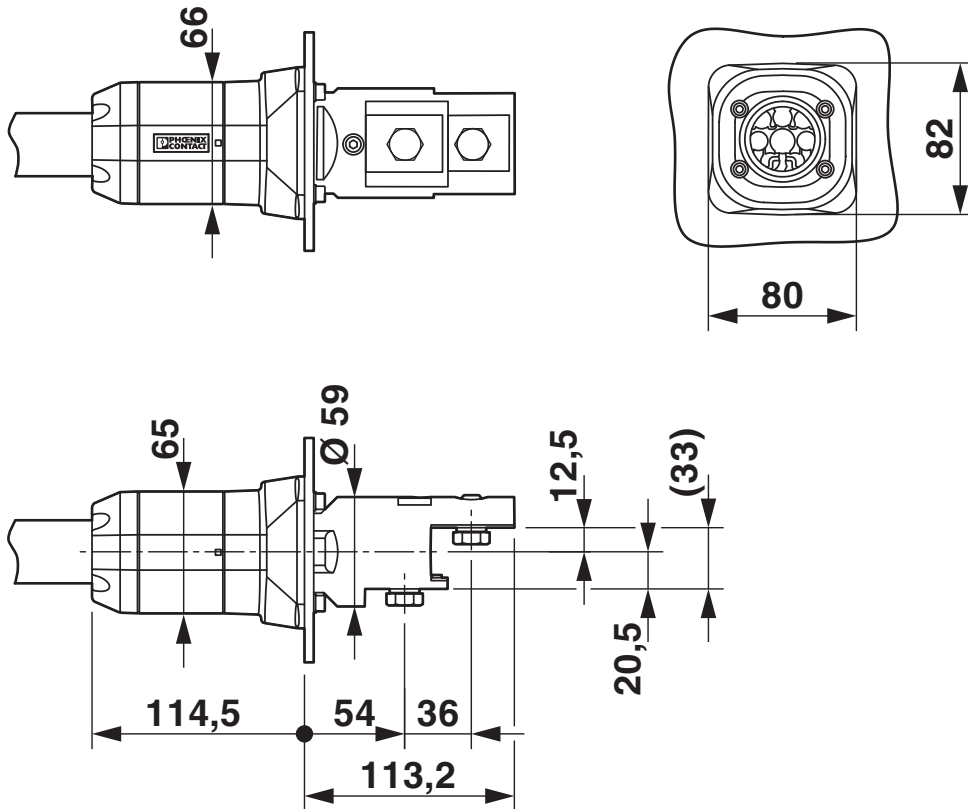

Straight panel feed-through

Schematic diagram

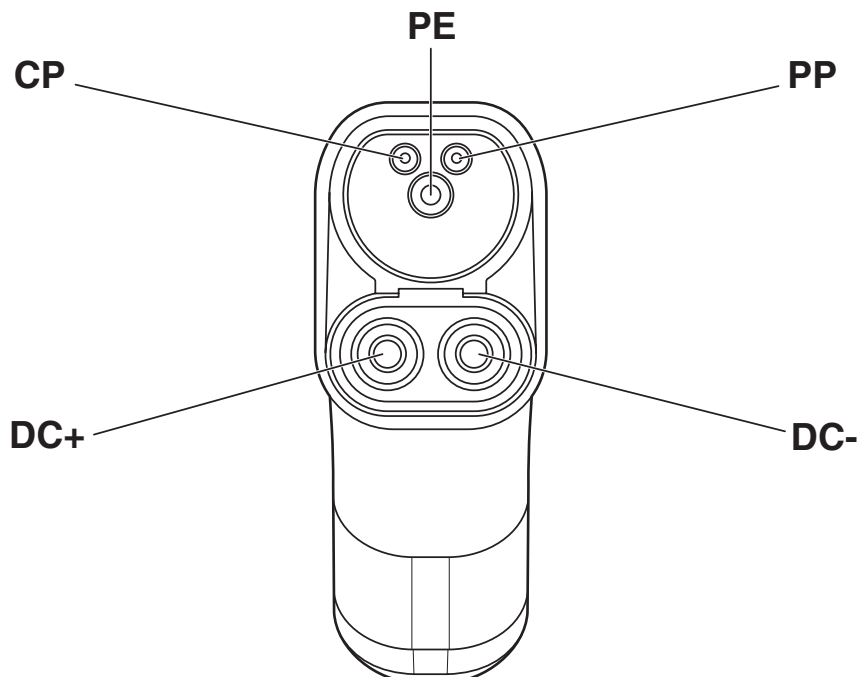

Pin assignment of the Vehicle Connector

EV-T2HPCC-DC400A-5,0M50ECBK11S - DC charging cable



1052444

<https://www.phoenixcontact.com/us/products/1052444>

Schematic diagram

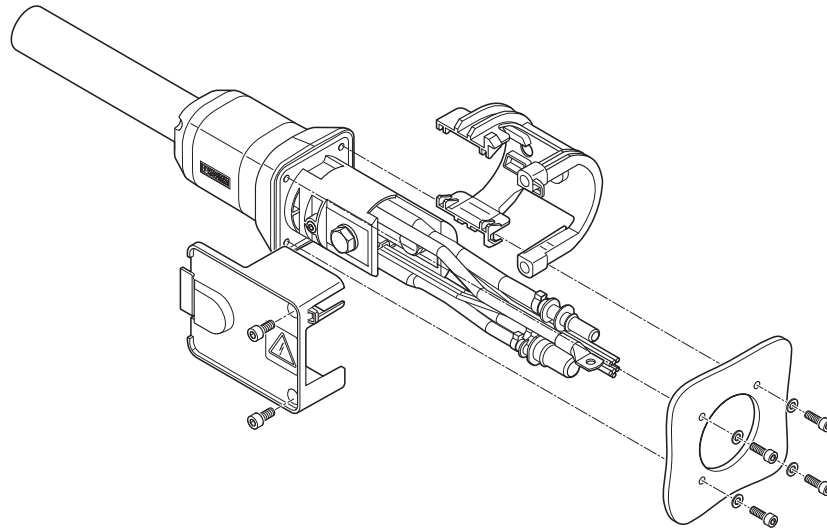

Assembly instructions for attaching the touch protection using straight panel feed-through as an example

Schematic diagram

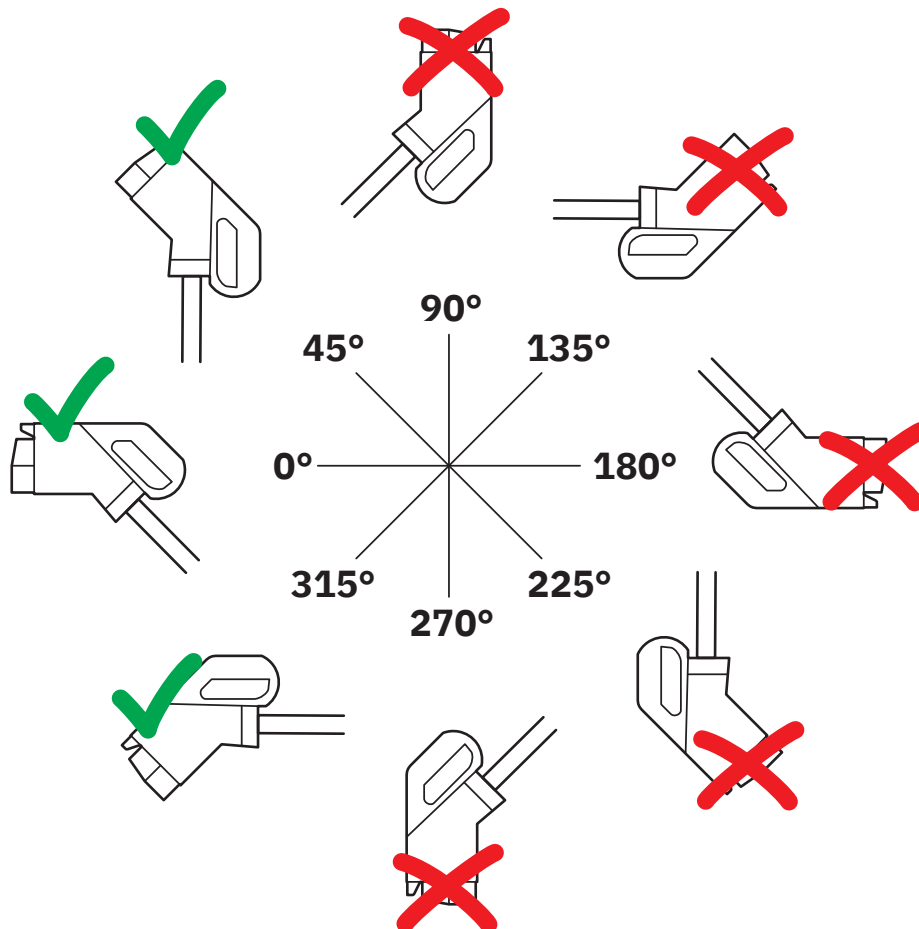

The resting position must be installed in the charging station such that the user cannot hang up the vehicle connector upside down (90° to 270°). However, positions rotated upward (45°) or downward (315°) are options for a resting position.

EV-T2HPCC-DC400A-5,0M50ECBK11S - DC charging cable



1052444

<https://www.phoenixcontact.com/us/products/1052444>

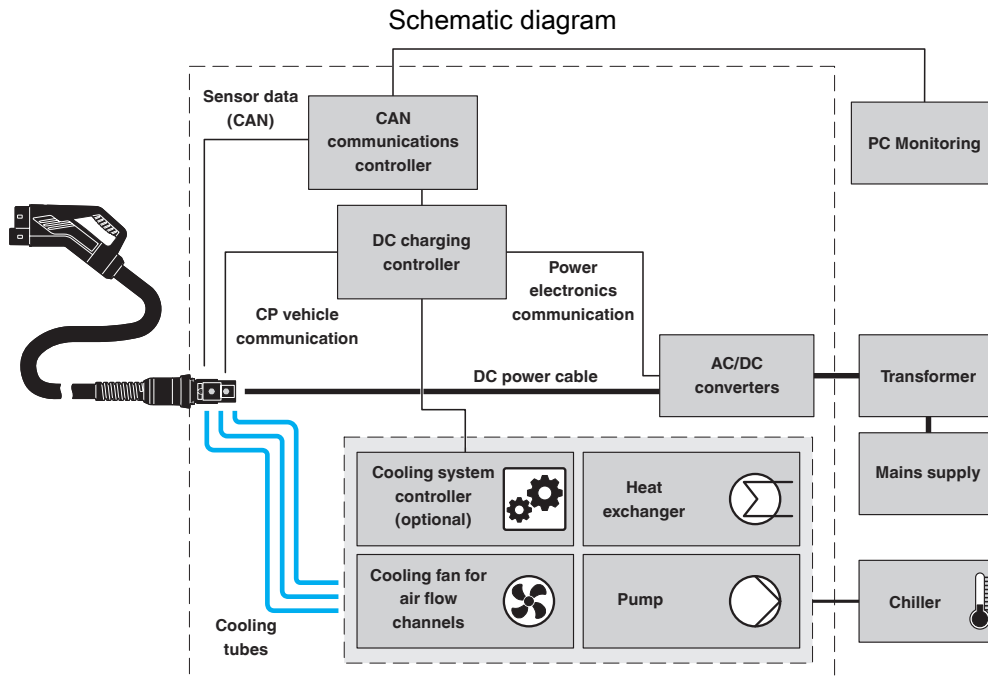

Central system: cooling unit and controller are positioned externally and supply multiple charging stations, each of which is equipped with a heat exchanger. The cooling is done actively using a chiller.

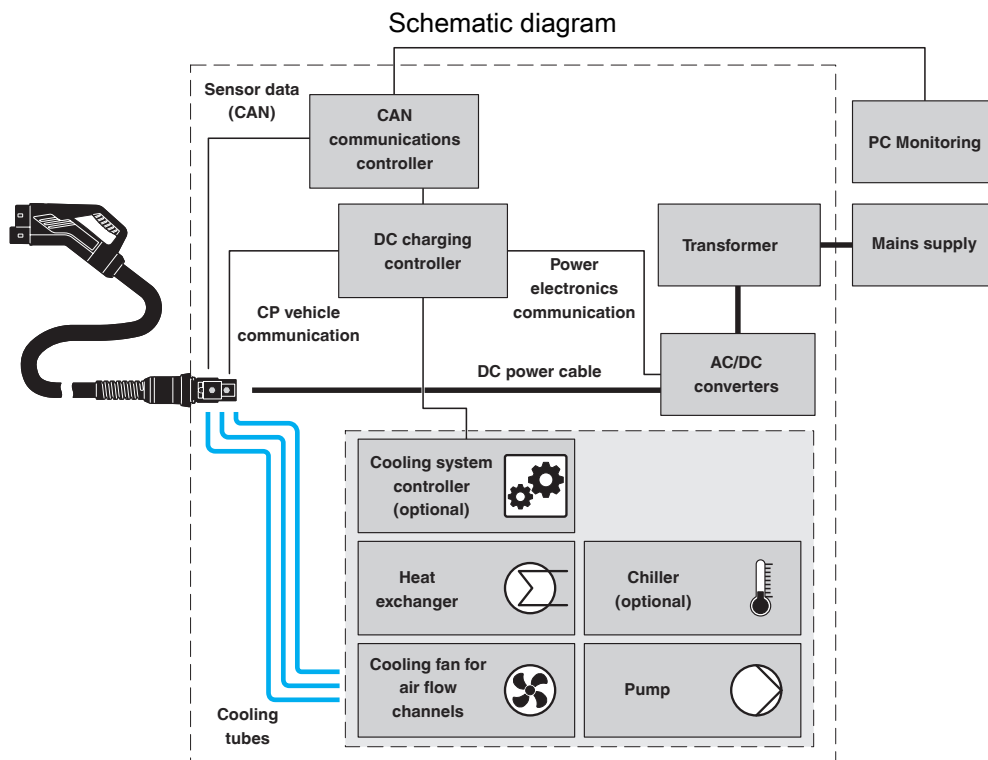

Standalone, decentralized system: cooling unit and controller are integrated into the charging station. The choice of cooling unit can be passive or active (i.e., with or without chiller).

EV-T2HPCC-DC400A-5,0M50ECBK11S - DC charging cable



1052444

<https://www.phoenixcontact.com/us/products/1052444>

Schematic diagram

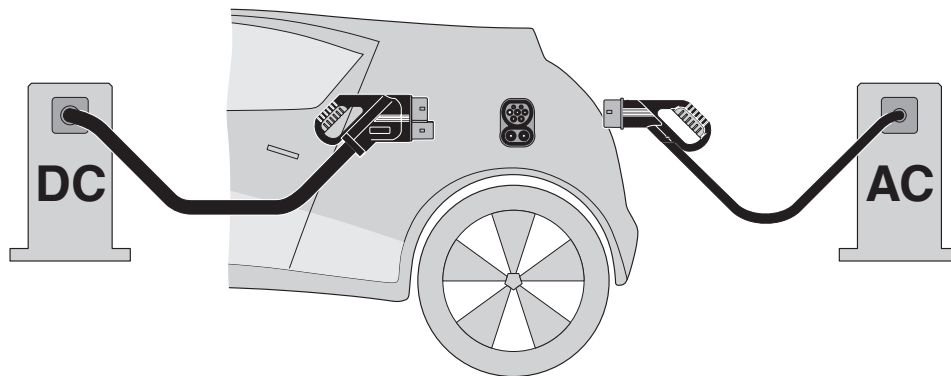

The Combined Charging System (CCS) principle - standard-compliant charging system for electric vehicles, which supports both conventional AC charging and fast DC charging. Both Vehicle Connectors fit into the CCS Vehicle Inlet.

Schematic diagram

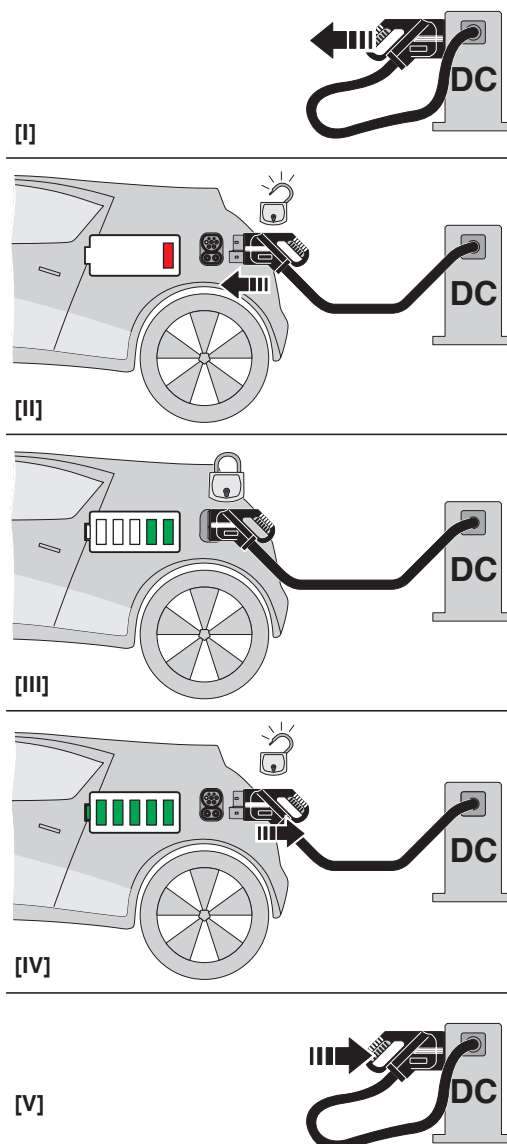

EV-T2HPCC-DC400A-5,0M50ECBK11S - DC charging cable



1052444

<https://www.phoenixcontact.com/us/products/1052444>

Classifications

ECLASS

ECLASS-13.0

27144705

ETIM

ETIM 9.0

EC002897

EV-T2HPCC-DC400A-5,0M50ECBK11S - DC charging cable



1052444

<https://www.phoenixcontact.com/us/products/1052444>

Environmental product compliance

China RoHS

Environment friendly use period (EFUP)	EFUP-10
	An article-related China RoHS declaration table can be found in the download area for the respective article under "Manufacturer declaration". For all articles with EFUP-E, no China RoHS declaration table issued and required.

EU REACH SVHC

REACH candidate substance (CAS No.)	No substance above 0.1 wt%
-------------------------------------	----------------------------

Phoenix Contact 2026 © - all rights reserved
<https://www.phoenixcontact.com>

Phoenix Contact USA
586 Fulling Mill Road
Middletown, PA 17057, United States
(+717) 944-1300
info@phoenixcon.com