

FL SWITCH 2508 - Industrial Ethernet Switch



1043484

<https://www.phoenixcontact.com/us/products/1043484>

Please be informed that the data shown in this PDF document is generated from our online catalog. Please find the complete data in the user documentation. Our general terms of use for downloads are valid.



Managed Switch 2000 series, 8 RJ45 ports 10/100/1000 Mbps, degree of protection: IP20, Ambient temperature (operation): -40 °C ... 70 °C, Supply voltage range: 19 V DC ... 32 V DC, PROFINET Conformance Class B, Extended temperature range, Development process certified in accordance with IEC 62443-4-1, Product certified in accordance with IEC 62443-4-2

Your advantages

- VLANs
- MRP (client and manager)
- Ambient temperature -40 °C ... 70 °C
- RSTP
- DHCP client, DHCP server (pool-based and port-based), DHCP option 82
- Configuration memory
- Web-based management, SNMP
- Easy and fast startup and commissioning with the FL NETWORK MANAGER software
- Suitable for PROFINET and EtherNet/IP™ networks

Commercial data

Item number	1043484
Packing unit	1 pc
Minimum order quantity	1 pc
Sales key	DN17
Product key	DNN122
GTIN	4055626611631
Weight per piece (including packing)	759 g
Weight per piece (excluding packing)	650 g
Customs tariff number	85176200
Country of origin	DE

FL SWITCH 2508 - Industrial Ethernet Switch



1043484

<https://www.phoenixcontact.com/us/products/1043484>

Technical data

Dimensions

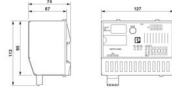
Dimensional drawing	
Width	128 mm
Height	113 mm
Depth	67 mm

Material specifications

Color (Housing)	Steel/stainless steel color
Material base plate	Die-cast aluminum, corrosion-resistant
Housing material	High-grade steel 1.4305

Mounting

Mounting type	DIN rail mounting
---------------	-------------------

Interfaces

Ethernet (RJ45)

Connection method	RJ45
Note on the connection method	Auto negotiation and autocrossing
Transmission speed	10/100/1000 Mbps
Transmission physics	Copper
Transmission length	100 m (per segment)
Signal LEDs	Data receive, link status
No. of channels	8 (RJ45 ports)

Product properties

Product type	Switch
Product family	Managed Switch 2000
Type	Block design
MTTF	357.82 Years (SN 29500 standard, temperature 25°C, operating cycle 21%)
	191.24 Years (SN 29500 standard, temperature 40°C, operating cycle 34.25%)
	25.65 Years (SN 29500 standard, temperature 70°C, operating cycle 100%)
Special properties	Extended temperature range
	Development process certified in accordance with IEC 62443-4-1
	Product certified in accordance with IEC 62443-4-2
Signal delay	≥ 1.9 μs (Store-and-Forward mode, 10/100/1000 Mbps, depending on the frame size)

FL SWITCH 2508 - Industrial Ethernet Switch



1043484

<https://www.phoenixcontact.com/us/products/1043484>

Insulation characteristics

Protection class	III (VDE 0106)
Degree of pollution	2

Switch functions

Diagnostic functions	RMON History
	LLDP (Link Layer Discovery Protocol)
	SNMP-Traps
	N:1-Portmirroring
	ACD (Address Conflict Detection)
	SysLog
	CRC-Surveillance
Basic functions	Store-and-forward switch, complies with IEEE 802.3
Signal contact control voltage	typ. 24 V DC
PROFINET conformance class	Conformance Class B
PROFINET device function	PROFINET device
	Fast Startup
Filter functions	Quality of Service (8 priority classes)
	Class of Service
	DiffServ/DSCP
	Port-Priorisierung
	VLAN (up to 32 VLANs)
	IGMP Snooping/Querier (v1/v2)
	Auto-Query-Port
	Extended Multicast Filtering
IP parameterization	DHCP client
	DHCP Option 82 (Relay Agent)
	DHCP server (pool-based, port-based)
	BootP
	DCP (Discovery and Configuration Protocol)
MAC address table	8k
Management	Web-based management (HTTP/HTTPS)
	Role-based user management (LDAP, RADIUS)
	SNMPv1/v2/v3
	Command Line Interface (Telnet, SSH)
Redundancy	MRP (Media Redundancy Protocol)
	RSTP (Rapid Spanning Tree Protocol)
	FRD (Fast Ring Detection)
	Large Tree Support
	LACP (Link Aggregation Control Protocol)
	PROFINET S2 system redundancy
Status and diagnostic indicators	LEDs: US1, US2 (power supply), Fail (alarm contact), 2 LEDs per Ethernet port (Link/Activity and Speed)
	Jumbo frames (max. 9,600 bytes)

FL SWITCH 2508 - Industrial Ethernet Switch



1043484

<https://www.phoenixcontact.com/us/products/1043484>

Additional functions	Transmission of MMS and GOOSE (IEC 61850-8-1)
	Transmission of Modbus/TCP
Time synchronization	SNTP (Simple Network Time Protocol)
Security functions	
Port security	MAC-based, RADIUS (IEEE 802.1X), MAC Authentication Bypass
Basic functions	Store-and-forward switch, complies with IEEE 802.3

Electrical properties

Local diagnostics	US1/2 Supply voltage US1, US2 Green LED
	FAIL Div. LED red
	LNK/ACT Link status Green LED
	SPD Data transmission speed Green/orange LED
Maximum power dissipation for nominal condition	6.08 W ($U_S = \max$, $T_{amb} = \max$)
Test section	24 V supply / functional ground 500 V DC 1 min
	Ethernet interface/all other potentials 2.25 kV DC 1 min
Transmission medium	Copper

Supply

Supply voltage (DC)	24 V DC (redundant)
Supply voltage range	19.2 V DC ... 32 V DC
Power supply connection	Via COMBICON, max. conductor cross-section 2.5 mm ²
Residual ripple	3.6 V _{PP} (within the permitted voltage range)
Max. current consumption	330 mA ($U_S = \min$, $T_{amb} = \max$)
Typical current consumption	230 mA (at $U_S = 24$ V DC and 25 °C ambient temperature)

Function

Signal contact control voltage	typ. 24 V DC
--------------------------------	--------------

Connection data

Connection method	Push-in spring connection
Note on the connection method	Use only copper connecting cables providing the permitted temperature range (-40 °C ... 75 °C)
pluggable	yes
Conductor cross-section, rigid	0.2 mm ² ... 1.5 mm ²
Conductor cross-section, flexible	0.2 mm ² ... 2.5 mm ²
Conductor cross-section AWG	24 ... 16
Stripping length	10 mm

Environmental and real-life conditions

Ambient conditions

Degree of protection	IP20
Ambient temperature (operation)	-40 °C ... 70 °C
Ambient temperature (storage/transport)	-40 °C ... 85 °C
Permissible humidity (operation)	10 % ... 95 % (non-condensing)

FL SWITCH 2508 - Industrial Ethernet Switch



1043484

<https://www.phoenixcontact.com/us/products/1043484>

Permissible humidity (storage/transport)	10 % ... 95 % (non-condensing)
Shock (operation)	30g (EN 60068-2-27)
Vibration (operation)	in acc. with IEC 60068-2-6: 5g, 150 Hz
Air pressure (operation)	79 kPa ... 108 kPa up to 2000 m above mean sea level (Without derating)
Air pressure (storage/transport)	79 kPa ... 108 kPa up to 2000 m above mean sea level (Without derating)

Standards and regulations

Free from substances that could impair the application of coating	Yes
---	-----

Approvals

UL, USA/Canada

Identification	cULus
----------------	-------

Corrosive gas test

Identification	ISA S71.04.2013 G3 Harsh Group A
----------------	----------------------------------

Shipbuilding data

Temperature	B
Humidity	B
Vibration	A
EMC	B
Enclosure	Required protection according to the Rules shall be provided upon installation on board

EMC data

Electromagnetic compatibility	Conformance with EMC Directive 2014/30/EU
Conformance with EMC directives	EN 61000-6-2 EN 61000-4-2 (ESD) Criterion B
	EN 61000-6-2 EN 61000-4-3 (electromagnetic fields) Criterion A
	EN 61000-6-2 EN 61000-4-4 (EFT burst) Criterion A
	EN 61000-6-2 EN 61000-4-5 (surge) Criterion A
	EN 61000-6-2 EN 61000-4-6 (line noise immunity) Criterion A
	EN 61000-6-2 EN 61000-6-4 (interference) Class A
Noise immunity	EN 61000-6-2 EN 61000-6-4 (conducted interference) Class A
	EN 61000-6-2

Noise emission

Standards/regulations	EN 61000-6-4
-----------------------	--------------

System properties

Functionality

Basic functions	Store-and-forward switch, complies with IEEE 802.3
-----------------	--

Signaling

Status display	LEDs: US1, US2 (power supply), Fail (alarm contact), 2 LEDs per
----------------	---

FL SWITCH 2508 - Industrial Ethernet Switch



1043484

<https://www.phoenixcontact.com/us/products/1043484>

	Ethernet port (Link/Activity and Speed)
--	---

FL SWITCH 2508 - Industrial Ethernet Switch



1043484

<https://www.phoenixcontact.com/us/products/1043484>

Drawings

Dimensional drawing

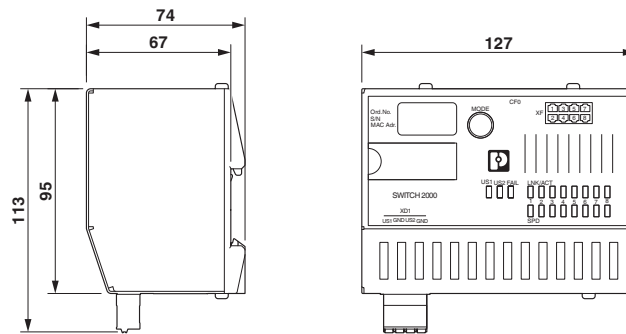

Connection diagram

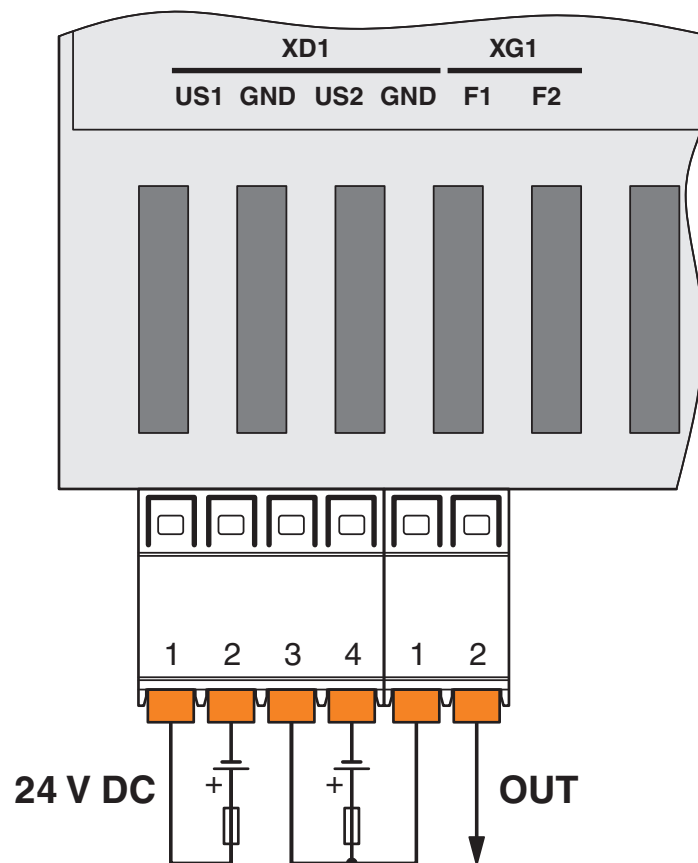

FL SWITCH 2508 - Industrial Ethernet Switch

1043484

<https://www.phoenixcontact.com/us/products/1043484>



Connection diagram



FL SWITCH 2508 - Industrial Ethernet Switch



1043484

<https://www.phoenixcontact.com/us/products/1043484>

Approvals

To download certificates, visit the product detail page: <https://www.phoenixcontact.com/us/products/1043484>



DNV GL

Approval ID: TAA00000YV



LR

Approval ID: LR22250919TA



BV

Approval ID: 48146_B1 BV

BSH

Approval ID: 1045

ABS

Approval ID: 21_2066186_1_PDA



RINA

Approval ID: ELE014724XG001



cULus Listed

Approval ID: E238705

Cybersecurity Certificate

Approval ID: 968 CSP 1043.00 25

FL SWITCH 2508 - Industrial Ethernet Switch



1043484

<https://www.phoenixcontact.com/us/products/1043484>

Classifications

ECLASS

ECLASS-13.0	19170401
ECLASS-15.0	19170401

ETIM

ETIM 10.0	EC000734
-----------	----------

UNSPSC

UNSPSC 21.0	43222600
-------------	----------

FL SWITCH 2508 - Industrial Ethernet Switch



1043484

<https://www.phoenixcontact.com/us/products/1043484>

Environmental product compliance

EU RoHS

Fulfills EU RoHS substance requirements	Yes
Exemption	7(a), 7(c)-I

China RoHS

Environment friendly use period (EFUP)	EFUP-50
	An article-related China RoHS declaration table can be found in the download area for the respective article under "Manufacturer declaration". For all articles with EFUP-E, no China RoHS declaration table issued and required.

EU REACH SVHC

REACH candidate substance (CAS No.)	Lead(CAS: 7439-92-1)
SCIP	49202abb-28d3-47e7-a665-2768038e0eb6

Phoenix Contact 2026 © - all rights reserved

<https://www.phoenixcontact.com>

Phoenix Contact USA
586 Fulling Mill Road
Middletown, PA 17057, United States
(+717) 944-1300
info@phoenixcon.com