

# VAL-MS 1500DC-PV-ST - Type 2 surge protection plug



1033727

<https://www.phoenixcontact.com/us/products/1033727>

Please be informed that the data shown in this PDF document is generated from our online catalog. Please find the complete data in the user documentation. Our general terms of use for downloads are valid.



Pack of three replacement plugs for PV arrester combinations from the VAL-MS 1500DC-PV-... product range

## Your advantages

- Increased safety, thanks to compliance with standard EN 50539-11
- Reliable contact, thanks to integrated rotating latch
- Easy replacement, thanks to plug-in arresters
- Optimum inverter protection, thanks to low protection level
- Efficient replacement of defective plugs, thanks to visual status indicator
- Protection against mismatching, thanks to keyed plugs and base elements

## Commercial data

Item number	1033727
Packing unit	1 pc
Minimum order quantity	1 pc
Sales key	CL01
Product key	CL1324
GTIN	4055626540504
Weight per piece (including packing)	84.5 g
Weight per piece (excluding packing)	84.5 g
Customs tariff number	85354000
Country of origin	DE

1033727

<https://www.phoenixcontact.com/us/products/1033727>

## Technical data

### Notes

#### General

Note	The device is intended for touch proof installation in a housing. Ensure that there is a gap of at least 8 mm between the active and grounded parts in the connection area.
------	---

### Product properties

Product type	Replacement plug
Product family	VALVETRAB MS
IEC test classification	PV II PV T2
EN type	T2
IEC power supply system	DC
Type	Male
Distance between live and grounded parts	8 mm
Environment	Indoor
Installation location of the disconnect device	Internal
Accessibility	Accessible
End-of-life mode	OCFM (Open-Circuit Failure Mode)
Surge protection fault message	optical

#### Insulation characteristics

Overvoltage category	III
Pollution degree	2

### Connection data

Connection method	pluggable
-------------------	-----------

### Dimensions

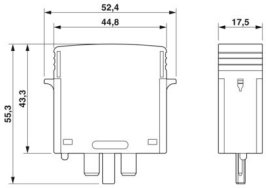
Dimensional drawing	
Width	17.5 mm
Height	52.4 mm
Depth	55.3 mm
Horizontal pitch	1 Div.

### Material specifications

Color	black (RAL 9005)
-------	------------------

1033727

<https://www.phoenixcontact.com/us/products/1033727>

Flammability rating according to UL 94	V-0
CTI value of material	600
Insulating material	PA 6.6-FR
	PBT-FR
Material group	I
Housing material	PA 6.6-FR
	PBT-FR

## Protective circuit

Direction of action	(L+)-PE & (L-)-PE & (L+)-(L-)
Standby power consumption $P_C$	$\leq 250$ mVA
Nominal discharge current $I_n$ (8/20) $\mu\text{s}$	15 kA
Maximum discharge current $I_{\text{max}}$ (8/20) $\mu\text{s}$	30 kA
Voltage protection level $U_p$	$\leq 2.5$ kV
Residual voltage $U_{\text{res}}$	$\leq 1.9$ kV (at 3 kA)
	$\leq 2.1$ kV (at 5 kA)
	$\leq 2.2$ kV (at 10 kA)
	$\leq 2.5$ kV (at 15 kA)
	$\leq 2.7$ kV (at 20 kA)
	$\leq 2.9$ kV (at 30 kA)
	$\leq 3$ kV (at 40 kA)
Response time $t_A$	$\leq 25$ ns

## Protective circuit DC voltage side (DC)

Maximum continuous operating voltage $U_{\text{CPV}}$	750 V DC
Short-circuit current rating $I_{\text{SCPV}}$	2000 A
Open-circuit voltage $U_{\text{OCSTC}}$	$\leq 625$ V DC
Maximum discharge current $I_{\text{max}}$ (8/20) $\mu\text{s}$	30 kA
Response time $t_A$	$\leq 25$ ns
Nominal discharge current $I_n$ (8/20) $\mu\text{s}$	15 kA
Continuous operating current $I_{\text{CPV}}$	$< 350$ $\mu\text{A}$
Maximum continuous operating voltage $U_{\text{CPV}}$	750 V DC
Short-circuit current rating $I_{\text{SCPV}}$	2000 A
Residual voltage $U_{\text{res}}$	$\leq 1.9$ kV (at 3 kA)
	$\leq 2.1$ kV (at 5 kA)
	$\leq 2.2$ kV (at 10 kA)
	$\leq 2.5$ kV (at 15 kA)
	$\leq 2.7$ kV (at 20 kA)
	$\leq 2.9$ kV (at 30 kA)
	$\leq 3$ kV (at 40 kA)
Voltage protection level $U_p$	$\leq 2.5$ kV
Standby power consumption $P_C$	$\leq 250$ mVA

## Additional technical data

Maximum discharge current $I_{\text{max}}$ (8/20) $\mu\text{s}$	40 kA
---	-------

# VAL-MS 1500DC-PV-ST - Type 2 surge protection plug



1033727

<https://www.phoenixcontact.com/us/products/1033727>

Nominal discharge current $I_n$ (8/20) $\mu$ s	20 kA (4x (5x $I_n$   120 s)   30 min))
--	---

## Environmental and real-life conditions

### Ambient conditions

Degree of protection	IP20
Ambient temperature (operation)	-40 °C ... 85 °C
Ambient temperature (storage/transport)	-40 °C ... 85 °C
Altitude	≤ 3000 m (amsl)
Permissible humidity (operation)	5 % ... 95 %
Shock (operation)	30g (Half-sine / 11 ms / 3x $\pm$ X, $\pm$ Y, $\pm$ Z)
Vibration (operation)	5g (5-500 Hz/2.5 h/XYZ)

## Approvals

### UL specifications

Maximum continuous operating voltage MCOV	1500 V DC
Short-circuit current rating (SCCR)	50 kA
Voltage protection rating VPR	4 kV
Nominal discharge current $I_n$	10 kA
Mode of protection	(DC+) - (DC-) (DC+) - G (DC-) - G
Nominal voltage	1500 V DC
Power distribution system	DC PV
SPD Type	1CA

## Standards and regulations

Standards/specifications	EN 61643-31
Note	2019
Standards/specifications	IEC 61643-31
Note	2018

## Mounting

Mounting type	on base element
---------------	-----------------

# VAL-MS 1500DC-PV-ST - Type 2 surge protection plug



1033727

<https://www.phoenixcontact.com/us/products/1033727>

## Drawings

Dimensional drawing



Circuit diagram



# VAL-MS 1500DC-PV-ST - Type 2 surge protection plug



1033727

<https://www.phoenixcontact.com/us/products/1033727>

## Approvals

To download certificates, visit the product detail page: <https://www.phoenixcontact.com/us/products/1033727>



**cUL Recognized**

Approval ID: FILE E 330181



**UL Recognized**

Approval ID: FILE E 330181

**CCA**

Approval ID: NTR-NL 7937



**KEMA-KEUR**

Approval ID: 71-123544 REV.3



**IECEE CB Scheme**

Approval ID: NL-81006/A1

**UAE-RoHS**

Approval ID: 22-09-51250

# VAL-MS 1500DC-PV-ST - Type 2 surge protection plug



1033727

<https://www.phoenixcontact.com/us/products/1033727>

## Classifications

### ECLASS

ECLASS-13.0	27171492
ECLASS-15.0	27171492

### ETIM

ETIM 10.0	EC002496
-----------	----------

### UNSPSC

UNSPSC 21.0	39121620
-------------	----------

1033727

<https://www.phoenixcontact.com/us/products/1033727>

## Environmental product compliance

### EU RoHS

Fulfills EU RoHS substance requirements	Yes, No exemptions
---	--------------------

### China RoHS

Environment friendly use period (EFUP)	EFUP-E
	No hazardous substances above the limits

### EU REACH SVHC

REACH candidate substance (CAS No.)	No substance above 0.1 wt%
-------------------------------------	----------------------------

### EF3.1 Climate Change

CO2e kg	2.535 kg CO2e
---------	---------------

Phoenix Contact 2026 © - all rights reserved  
<https://www.phoenixcontact.com>

Phoenix Contact USA  
586 Fulling Mill Road  
Middletown, PA 17057, United States  
(+717) 944-1300  
[info@phoenixcon.com](mailto:info@phoenixcon.com)