

# FL SWITCH 2316 PN - Industrial Ethernet Switch



1031673

<https://www.phoenixcontact.com/us/products/1031673>

Please be informed that the data shown in this PDF document is generated from our online catalog. Please find the complete data in the user documentation. Our general terms of use for downloads are valid.



The figure shows a version of the product

Managed Switch 2000 series, 16 RJ45 ports 10/100/1000 Mbps, degree of protection: IP20, Ambient temperature (operation): -40 °C ... 70 °C, Supply voltage range: 12 V DC ... 57 V DC, PROFINET Conformance Class B, Extended temperature range, PROFINET mode preset, PROFINET status LEDs, Development process certified in accordance with IEC 62443-4-1, Product certified in accordance with IEC 62443-4-2

## Your advantages

- RSTP
- Ambient temperature -40 °C ... 70 °C
- MRP (client and manager)
- VLANs
- DHCP client, DHCP server (pool-based and port-based), DHCP option 82
- Web-based management, SNMP
- Configuration memory
- Easy and fast startup and commissioning with the FL NETWORK MANAGER software
- PROFINET mode preset



## Commercial data

Item number	1031673
Packing unit	1 pc
Minimum order quantity	1 pc
Sales key	DN17
Product key	DNN121
GTIN	4055626535265
Weight per piece (including packing)	636.5 g

# FL SWITCH 2316 PN - Industrial Ethernet Switch



1031673

<https://www.phoenixcontact.com/us/products/1031673>

Weight per piece (excluding packing)	445 g
Customs tariff number	85176200
Country of origin	DE

# FL SWITCH 2316 PN - Industrial Ethernet Switch



1031673

<https://www.phoenixcontact.com/us/products/1031673>

## Technical data

### Dimensions

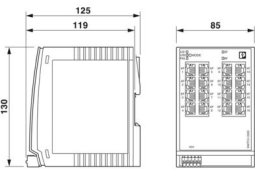
Dimensional drawing	
Width	85 mm
Height	130 mm
Depth	119 mm

### Notes

#### Utilization restriction

EMC note	EMC: class A product, see manufacturer's declaration in the download area
----------	---

### Material specifications

Color (Housing)	gray (RAL 7042)
Color (Cover)	light gray (RAL 7035)
Housing material	Polycarbonate fiber reinforced

### Mounting

Mounting type	DIN rail mounting
---------------	-------------------

### Interfaces

#### Ethernet (RJ45)

Connection method	RJ45
Note on the connection method	Auto negotiation and autocrossing
Transmission speed	10/100/1000 Mbps
Transmission physics	Copper
Transmission length	100 m (per segment)
Signal LEDs	Data receive, link status
No. of channels	16 (RJ45 ports)

### Output data

#### Digital:

Output name	Alarm output
-------------	--------------

### Product properties

Product type	Switch
Product family	Managed Switch 2000

# FL SWITCH 2316 PN - Industrial Ethernet Switch



1031673

<https://www.phoenixcontact.com/us/products/1031673>

Type	Book type
MTTF	379.84 Years (SN 29500 standard, temperature 25°C, operating cycle 21%)
	199.41 Years (SN 29500 standard, temperature 40°C, operating cycle 34.25%)
	27.52 Years (SN 29500 standard, temperature 55°C, operating cycle 100%)
Special properties	Extended temperature range
	PROFINET mode preset, PROFINET status LEDs
	Development process certified in accordance with IEC 62443-4-1
	Product certified in accordance with IEC 62443-4-2
Signal delay	≥ 1.9 μs (Store-and-Forward mode, 10/100/1000 Mbps, depending on the frame size)

## Insulation characteristics

Protection class	III (VDE 0106)
Degree of pollution	2

## Switch functions

Diagnostic functions	RMON History
	LLDP (Link Layer Discovery Protocol)
	SNMP-Traps
	N:1-Portmirroring
	ACD (Address Conflict Detection)
	SysLog
	CRC-Surveillance
Basic functions	Store-and-forward switch, complies with IEEE 802.3
Signal contact control voltage	typ. 24 V DC
PROFINET conformance class	Conformance Class B
PROFINET device function	PROFINET device
	Fast Startup
Filter functions	Quality of Service (8 priority classes)
	Class of Service
	DiffServ/DSCP
	Port-Priorisierung
	VLAN (up to 32 VLANs)
	IGMP Snooping/Querier (v1/v2)
	Auto-Query-Port
	Extended Multicast Filtering
IP parameterization	DHCP client
	DHCP Option 82 (Relay Agent)
	DHCP server (pool-based, port-based)
	BootP
	DCP (Discovery and Configuration Protocol)
MAC address table	8k
	Web-based management (HTTP/HTTPS)

# FL SWITCH 2316 PN - Industrial Ethernet Switch



1031673

<https://www.phoenixcontact.com/us/products/1031673>

Management	Role-based user management (LDAP, RADIUS)
	SNMPv1/v2/v3
	Command Line Interface (Telnet, SSH)
Redundancy	MRP (Media Redundancy Protocol)
	RSTP (Rapid Spanning Tree Protocol)
	FRD (Fast Ring Detection)
	Large Tree Support
	LACP (Link Aggregation Control Protocol)
	PROFINET S2 system redundancy
Status and diagnostic indicators	LEDs: US1, US2 (power supply), Fail (alarm contact), 2 LEDs per Ethernet port (link/activity and speed), PROFINET status LEDs (BF, SF)
Additional functions	Jumbo frames (max. 9,600 bytes)
	Transmission of MMS and GOOSE (IEC 61850-8-1)
	Transmission of Modbus/TCP
Time synchronization	SNTP (Simple Network Time Protocol)
Security functions	
Port security	MAC-based, RADIUS (IEEE 802.1X), MAC Authentication Bypass
Basic functions	Store-and-forward switch, complies with IEEE 802.3

## Electrical properties

Current consumption	455 mA
Local diagnostics	US1/2 Supply voltage US1, US2 Green LED
	FAIL Div. LED red
	LINK Link status Green LED
	BF Bus errors LED red
	SF Group error LED red
Maximum power dissipation for nominal condition	13.2 W ( $U_S = \text{Min}$ , $T_{\text{amb}} = \text{Max}$ , $DO_I = \text{Max}$ )
Test section	24 V supply / functional ground 500 V DC 1 min
	Ethernet interface/all other potentials 2.25 kV DC 1 min
Transmission medium	Copper

## Supply

Supply voltage (DC)	24 V DC (redundant)
Supply voltage range	12 V DC ... 57 V DC
Power supply connection	via COMBICON, max. conductor cross-section 1.5 mm <sup>2</sup>
Residual ripple	3.6 V <sub>PP</sub> (within the permitted voltage range)
Max. current consumption	1.8 A ( $U_S = \text{Min}$ , $T_{\text{amb}} = \text{Max}$ , $DO_I = \text{Max}$ )
Typical current consumption	455 mA (at $U_S = 24$ V DC and 25 °C ambient temperature)
Current consumption	455 mA

## Function

Signal contact control voltage	typ. 24 V DC
--------------------------------	--------------

1031673

<https://www.phoenixcontact.com/us/products/1031673>

## Connection data

Connection method	Push-in spring connection
Note on the connection method	Use only copper connecting cables providing the permitted temperature range (-40 °C ... 75 °C)
pluggable	yes
Conductor cross-section, rigid	0.25 mm <sup>2</sup> ... 1.5 mm <sup>2</sup>
Conductor cross-section, flexible	0.25 mm <sup>2</sup> ... 1.5 mm <sup>2</sup>
Conductor cross-section AWG	24 ... 16
Stripping length	9 mm

## Environmental and real-life conditions

### Ambient conditions

Degree of protection	IP20
Ambient temperature (operation)	-40 °C ... 70 °C
Ambient temperature (storage/transport)	-40 °C ... 85 °C
Permissible humidity (operation)	10 % ... 95 % (non-condensing)
Permissible humidity (storage/transport)	10 % ... 95 % (non-condensing)
Shock (operation)	30g (EN 60068-2-27)
Vibration (operation)	in acc. with IEC 60068-2-6: 5g, 150 Hz
Air pressure (operation)	80 kPa ... 110 kPa up to 2000 m above mean sea level (Without derating)
Air pressure (storage/transport)	79 kPa ... 108 kPa up to 2000 m above mean sea level (Without derating)

## Standards and regulations

Free from substances that could impair the application of coating	Yes
---	-----

## Approvals

Shipbuilding approval	Tested in accordance with IEC 60945 and IACS E10
-----------------------	--

### ATEX

Identification	⊕ II 3 G Ex ec IIC T4 Gc
Certificate	DEMKO 16 ATEX 1709X

### IECEX

Identification	Ex ec IIC T4 Gc
Certificate	IECEX ULD 16.0018 X

### UL, USA/Canada

Identification	cULus
----------------	-------

### UL Ex, USA / Canada

Identification	Class I, Division 2, Groups A, B, C, and D, T4
	Class I, Zone 2, AEx ec IIC T4
	Ex ec IIC T4 Gc X
Certificate	E366272

# FL SWITCH 2316 PN - Industrial Ethernet Switch



1031673

<https://www.phoenixcontact.com/us/products/1031673>

Note	UL 60079-0 Ed. 6 / UL 60079-7 Ed. 5, CSA 22.2 No. 60079-0 Ed. 3 / CSA C22.2 No. 60079-7 Ed. 2
------	---

## EAC Ex

Identification	2Ex e IIC T4 Gc X
Certificate	RU C-DE.HB49.B.00118/21

The following continue to apply for EAC Ex:

Identification	Install the device in a suitable, approved housing with at least IP66 protection.
	The housing/control cabinet must be equipped with a warning sign prohibiting opening in the potentially explosive area.
	The operation of devices is permitted if all optical ports are connected or sealed with the supplied filler plugs.

## CCC / China-Ex

Identification	Ex ec IIC T4 Gc
Certificate	2022122310115629

## Corrosive gas test

Identification	ISA S71.04.2013 G3 Harsh Group A
----------------	----------------------------------

## UKCA Ex (UKEX)

Identification	Ⓢ II 3 G Ex ec IIC T4 Gc
Certificate	PxCIMA22UKEX2702910X

## Shipbuilding data

Temperature	B
Humidity	B
Vibration	A
EMC	B
Enclosure	Required protection according to the Rules shall be provided upon installation on board

## EMC data

Electromagnetic compatibility	Conformance with EMC Directive 2014/30/EU
Conformance with EMC directives	EN 61000-6-2 EN 61000-4-2 (ESD) Criterion B
	EN 61000-6-2 EN 61000-4-3 (electromagnetic fields) Criterion A
	EN 61000-6-2 EN 61000-4-4 (EFT burst) Criterion A
	EN 61000-6-2 EN 61000-4-5 (surge) Criterion A
	EN 61000-6-2 EN 61000-4-6 (line noise immunity) Criterion A
	EN 61000-6-2 EN 61000-6-3 (noise emission) Class B
Noise immunity	EN 61000-6-2 EN 61000-6-3 (conducted emissions) Class B
	EN 61000-6-2

## Noise emission

Standards/regulations	EN 61000-6-4
-----------------------	--------------

## System properties

# FL SWITCH 2316 PN - Industrial Ethernet Switch



1031673

<https://www.phoenixcontact.com/us/products/1031673>

## Functionality

Basic functions

Store-and-forward switch, complies with IEEE 802.3

## Signaling

Status display

LEDs: US1, US2 (power supply), Fail (alarm contact), 2 LEDs per Ethernet port (link/activity and speed), PROFINET status LEDs (BF, SF)

# FL SWITCH 2316 PN - Industrial Ethernet Switch



1031673

<https://www.phoenixcontact.com/us/products/1031673>

## Drawings

Dimensional drawing

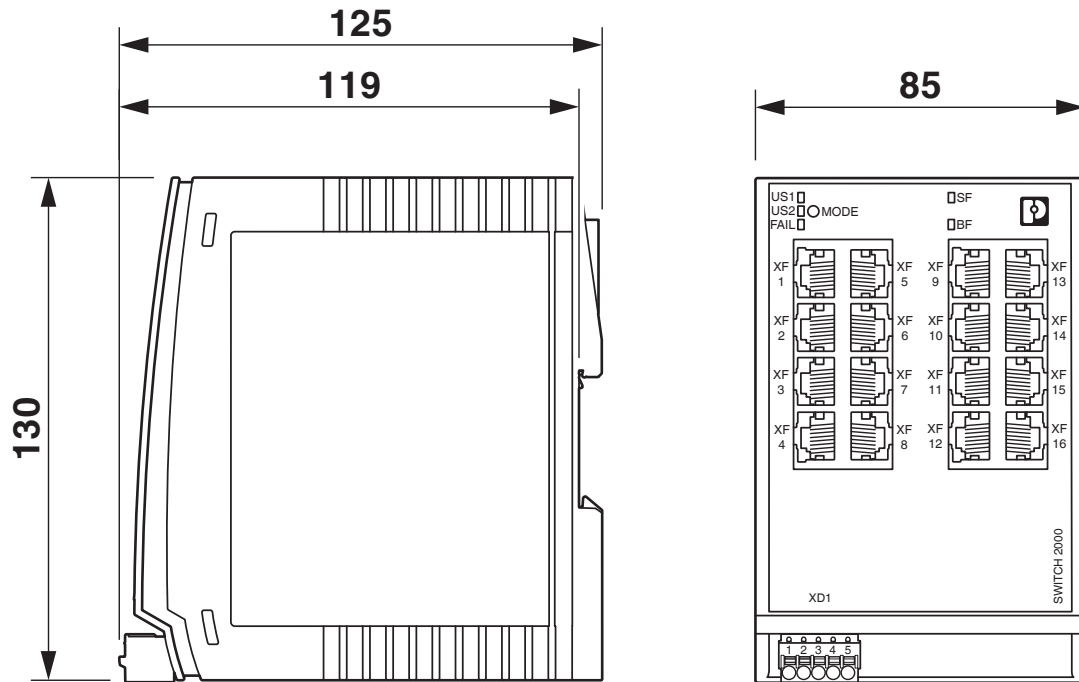

# FL SWITCH 2316 PN - Industrial Ethernet Switch



1031673

<https://www.phoenixcontact.com/us/products/1031673>

## Approvals

To download certificates, visit the product detail page: <https://www.phoenixcontact.com/us/products/1031673>



**DNV GL**

Approval ID: TAA00000YV



**LR**

Approval ID: LR22250919TA



**NK**

Approval ID: TA24215M



**BV**

Approval ID: 48146\_B1 BV

**BSH**

Approval ID: 1045



**RINA**

Approval ID: ELE014724XG001

**ABS**

Approval ID: 21\_2066186\_1\_PDA



**cULus Listed**

Approval ID: E238705

**PROFINET**

Approval ID: Z12628

**Cybersecurity Certificate**

Approval ID: 968 CSP 1043.00 25

**PROFINET**

Approval ID: Z12624-Z12639

# FL SWITCH 2316 PN - Industrial Ethernet Switch



1031673

<https://www.phoenixcontact.com/us/products/1031673>

## ABS

Approval ID: 21\_2066186\_1\_PDA

## BSH

Approval ID: 1045



## BV

Approval ID: 48146\_B1 BV



## DNV GL

Approval ID: TAA00000YV



## NK

Approval ID: TA24215M



## RINA

Approval ID: ELE014724XG001



## LR

Approval ID: LR22250919TA



## cULus Listed

Approval ID: E238705

## PROFINET

Approval ID: Z12624-Z12639

## Cybersecurity Certificate

Approval ID: 968 CSP 1043.00 25



## IECEX

Approval ID: IECEX ULD 16.0018X



## ATEX

Approval ID: DEMKO 16 ATEX 1709X

# FL SWITCH 2316 PN - Industrial Ethernet Switch



1031673

<https://www.phoenixcontact.com/us/products/1031673>



**CCC**

Approval ID: 2022122310115629



**cULus Listed**

Approval ID: E366272



**cULus Listed**

Approval ID: E366272



**CCC**

Approval ID: 2022122310115629



**IECEx**

Approval ID: IECEx ULD 16.0018X



**ATEX**

Approval ID: DEMKO 16 ATEX 1709X

# FL SWITCH 2316 PN - Industrial Ethernet Switch



1031673

<https://www.phoenixcontact.com/us/products/1031673>

## Classifications

### ECLASS

ECLASS-13.0	19170401
ECLASS-15.0	19170401

### ETIM

ETIM 10.0	EC000734
-----------	----------

### UNSPSC

UNSPSC 21.0	43222600
-------------	----------

# FL SWITCH 2316 PN - Industrial Ethernet Switch



1031673

<https://www.phoenixcontact.com/us/products/1031673>

## Environmental product compliance

### EU RoHS

Fulfills EU RoHS substance requirements	Yes
Exemption	7(a), 7(c)-I

### China RoHS

Environment friendly use period (EFUP)	EFUP-50
	An article-related China RoHS declaration table can be found in the download area for the respective article under "Manufacturer declaration". For all articles with EFUP-E, no China RoHS declaration table issued and required.

### EU REACH SVHC

REACH candidate substance (CAS No.)	Lead(CAS: 7439-92-1)
SCIP	cdeba26b-132a-4c2c-b065-bb5357b5903a

Phoenix Contact 2026 © - all rights reserved

<https://www.phoenixcontact.com>

Phoenix Contact USA  
586 Fulling Mill Road  
Middletown, PA 17057, United States  
(+717) 944-1300  
[info@phoenixcon.com](mailto:info@phoenixcon.com)