

EV-CC-AC1-M3-CBC-RCM-ETH-3G - AC charging controller



1018702

<https://www.phoenixcontact.com/us/products/1018702>

Please be informed that the data shown in this PDF document is generated from our online catalog. Please find the complete data in the user documentation. Our general terms of use for downloads are valid.

AC charging controller in accordance with IEC 61851-1, server for load distribution to up to 5 clients, OCPP 1.6J via 3G modem, Modbus/TCP via Ethernet, connection of RFID reader and energy meter via RS-485, DC residual current monitoring, connector release in the event of power failure



Product description

Mode 3 controller for charging electric vehicles in accordance with IEC 61851-1 for charging case B and C with integrated DC residual current monitoring, Ethernet communication interface and 3G mobile network modem.

Commercial data

Item number	1018702
Packing unit	1 pc
Minimum order quantity	1 pc
Product key	XWBRCA
GTIN	4055626503974
Weight per piece (including packing)	611.3 g
Weight per piece (excluding packing)	480 g
Country of origin	DE

EV-CC-AC1-M3-CBC-RCM-ETH-3G - AC charging controller



1018702

<https://www.phoenixcontact.com/us/products/1018702>

Technical data

Product properties

Product type	AC charging controller
Product family	CHARX control advanced plus
Charging mode	Mode 3, Case B + C
Operating mode	Stand-Alone
	Client
	Server
Modem for communication present	yes
Number of charging points	1

Electrical properties

Type of charging current	AC
--------------------------	----

Measuring range: Residual current

Rated frequency f_n	≤ 2000 Hz
Nominal differential current	± 300 mA
Residual current $I_{\Delta n}$	30 mA (AC)
	6 mA (DC)
Rated current I_n	32 A (Three-phase, 4x6 mm ²)
	48 A (Single-phase)
Tripping time for $I_{\Delta n}$	< 180 ms
Response time for $2 \times I_{\Delta n}$	< 70 ms
Tripping time for $5 \times I_{\Delta n}$	< 20 ms

Input data

Digital

Number of digital inputs	5
Description of the input	Digital input
Nominal current I_N	≤ 4 mA
Nominal input voltage U_N	12 V
Input voltage range	0 V ... 3 V (Off)
Input voltage range U_2	9 V ... 15 V (On)

Output data

Digital

Output name	4 digital outputs
Connection technology	Screw connection
Maximum output voltage	30 V
Maximum output current	0.2 A (Total current for all outputs; internally supplied)
Maximum output current per channel	0.6 A (Per output; externally supplied)

EV-CC-AC1-M3-CBC-RCM-ETH-3G - AC charging controller



1018702

<https://www.phoenixcontact.com/us/products/1018702>

Switching

Output name	Relay output C _{1,2}
Minimum switching power	4000 VA
Maximum switching voltage	250 V AC (External supply)
Max. switching current	16 A

Switching

Output name	Motor switching output
Maximum switching voltage	12 V (Internal supply)
Max. switching current	1 A (maximum)

Connection data

Conductor cross-section rigid	0.2 mm ² ... 4 mm ²
Conductor cross-section flexible	0.2 mm ² ... 2.5 mm ²
Conductor cross-section AWG	24 ... 12
Conductor cross-section rigid	0.14 mm ² ... 1.5 mm ²
Conductor cross-section flexible	0.2 mm ² ... 1 mm ²
Conductor cross-section AWG	26 ... 16

Interfaces

Interface	Ethernet (1x) Cellular communication (3G/2G)
-----------	---

Wireless

Interface description	HSPA/GSM/GPRS/EDGE cellular interface for communicating with higher-level management systems using the OCPP 1.6J communication protocol
Frequency	900 MHz (HSPA) 2100 MHz (HSPA) 850 MHz (GSM/GPRS/EDGE) 900 MHz (GSM/GPRS/EDGE) 1800 MHz (GSM/GPRS/EDGE) 1900 MHz (GSM/GPRS/EDGE)
Transmission power	2 W (GSM 850 (Class 4)) 2 W (GSM 950 (Class 4)) 1 W (GSM 1800 (Class 1)) 1 W (GSM 1900 (Class 1)) + 24 dBm (UMTS/HSPA (Class 3))
Number	1
Connection method	SMA (male)
Impedance	50 Ω
SIM Interface	Micro SIM (3FF)
Protocols supported	OCPP 1.6J

RS-485

Interface	RS-485 2-wire
-----------	---------------

EV-CC-AC1-M3-CBC-RCM-ETH-3G - AC charging controller



1018702

<https://www.phoenixcontact.com/us/products/1018702>

Bus system	RS-485
Connection method	Screw connection
Number of interfaces	1 (for energy measurement device and RFID reader)
Number of supported devices	2
Transmission speed range	4.8 kbps ... 115.2 kbps (adjustable)
Protocols supported	Modbus/RTU (Master)

Ethernet

Interface	Ethernet
Connection method	RJ45 jack
Number of interfaces	1
Serial transmission speed	10/100 Mbps
Transmission length	100 m
Protocols supported	Modbus/TCP

Environmental and real-life conditions

Ambient conditions

Ambient temperature (operation)	-25 °C ... 60 °C
Ambient temperature (storage/transport)	-40 °C ... 85 °C
Altitude	< 2000 m
Permissible humidity (operation)	30 % ... 95 % (non-condensing)

EMC data

Electromagnetic compatibility	Conformance with EMC Directive 2014/30/EU
Low Voltage Directive	Conformance with Low Voltage Directive 2014/35/EC
Noise immunity	EN 61000-6-2
Immunity to the discharge of static electricity	EN 61000-4-2: 8 kV air, 4 kV contact discharge
Immunity to electromagnetic fields	EN 61 000-4-3, 80---1000 MHz, 10 V/m
Immunity to conducted high frequency	EN 61 000-4-6, 0.15...80 MHz, 10 V
Immunity to fast transients (Burst)	EN 61 000-4-4, 2 kV pos. and neg., 5 kHz
Housing	DIN 43880

Noise emission

Standards/regulations	EN 61000-6-3
-----------------------	--------------

Standards and regulations

Standards

Standards/regulations	IEC 61851-1
-----------------------	-------------

Mounting

Mounting type	DIN rail mounting
Assembly note	DIN rail mounting
Mounting position	any

EV-CC-AC1-M3-CBC-RCM-ETH-3G - AC charging controller



1018702

<https://www.phoenixcontact.com/us/products/1018702>

Drawings

Dimensional drawing

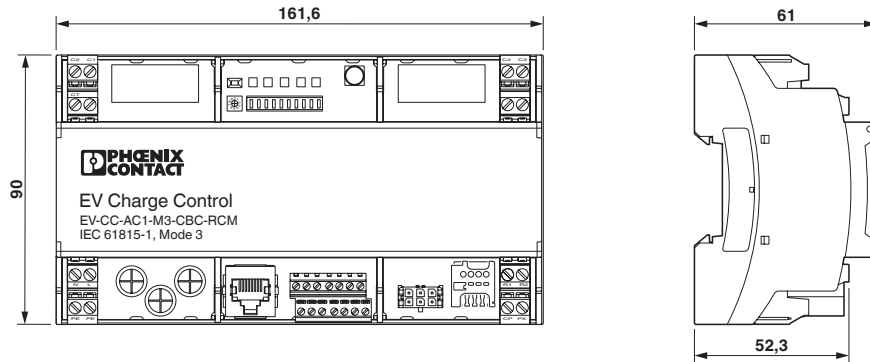

Dimensional drawing

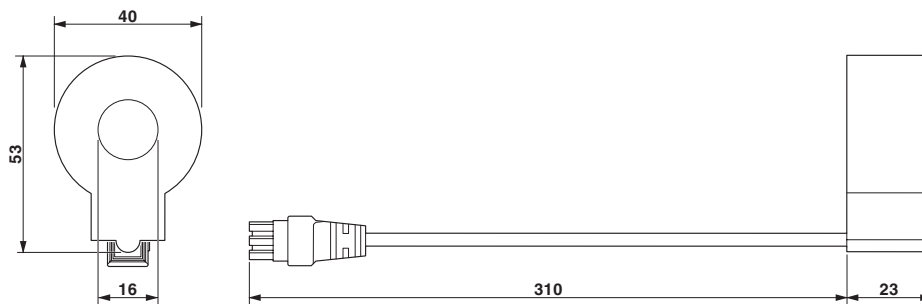

Connection diagram

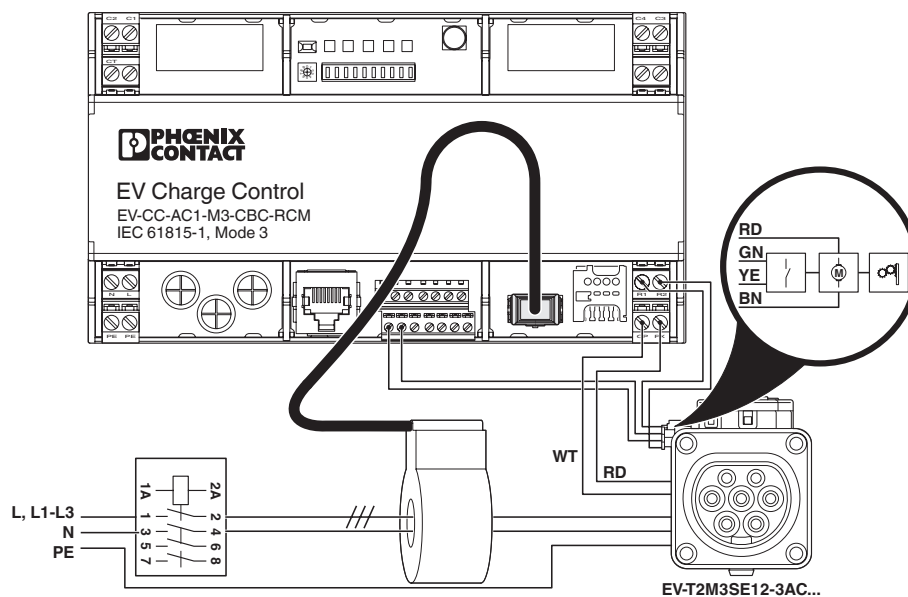

EV-CC-AC1-M3-CBC-RCM-ETH-3G - AC charging controller



1018702

<https://www.phoenixcontact.com/us/products/1018702>

Connection diagram

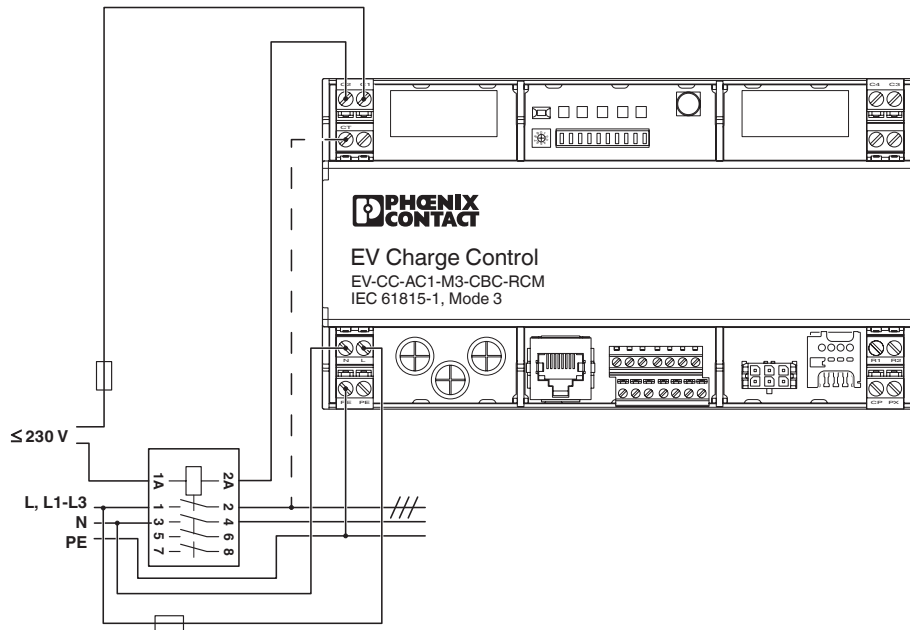

Connection diagram

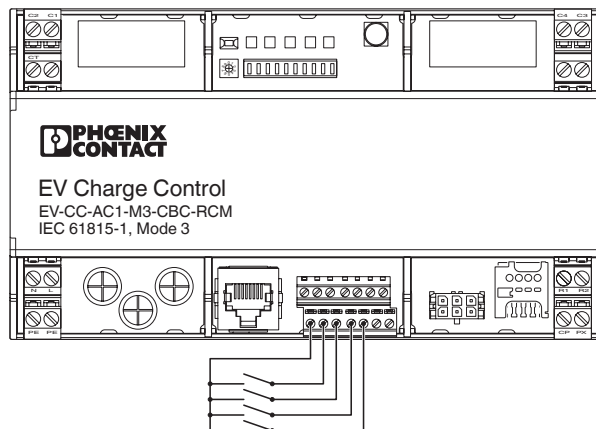

Connection diagram

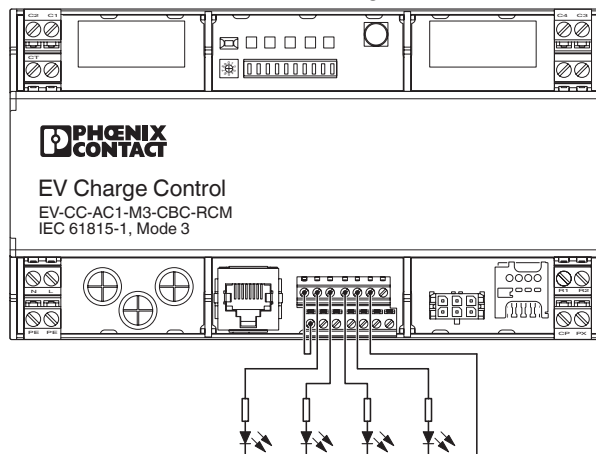

EV-CC-AC1-M3-CBC-RCM-ETH-3G - AC charging controller



1018702

<https://www.phoenixcontact.com/us/products/1018702>

Connection diagram

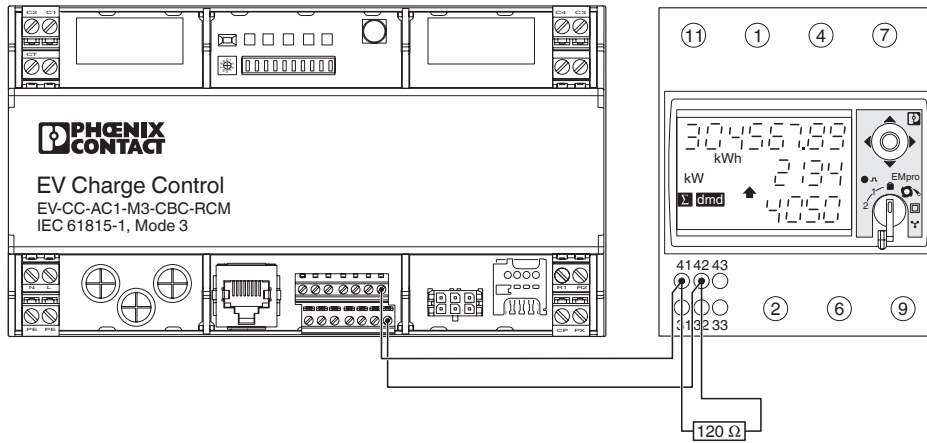

Connection diagram

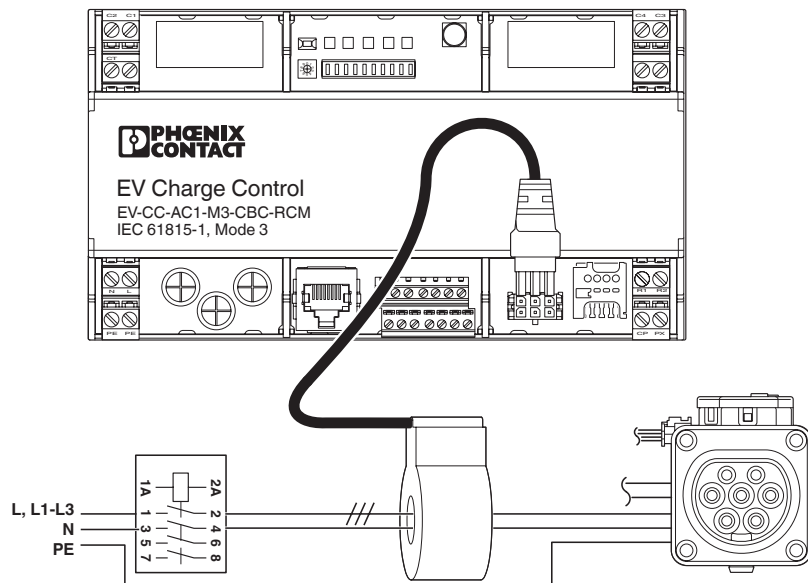

EV-CC-AC1-M3-CBC-RCM-ETH-3G - AC charging controller



1018702

<https://www.phoenixcontact.com/us/products/1018702>

Connection diagram

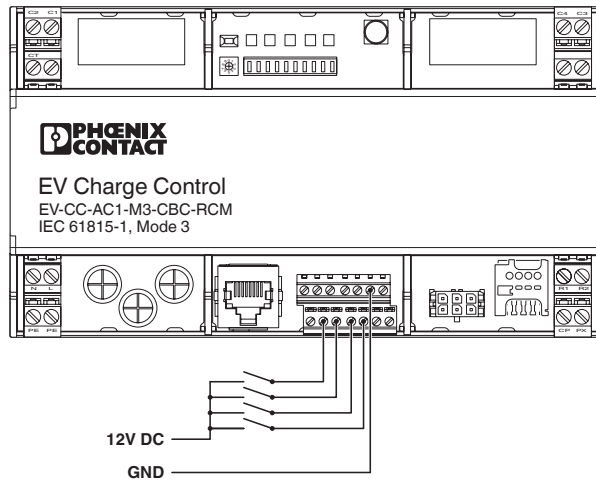

Connection diagram

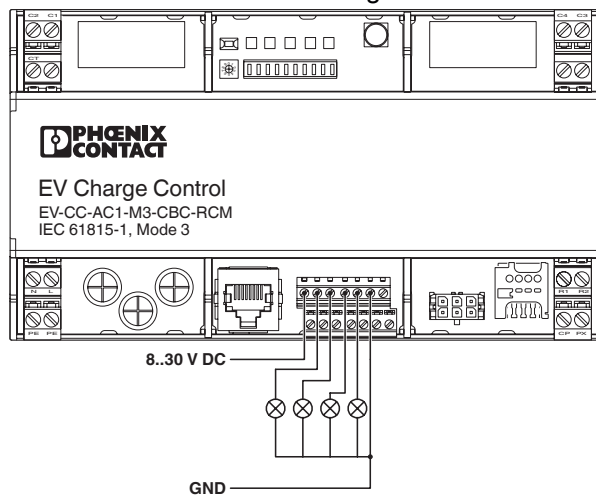

Connection diagram

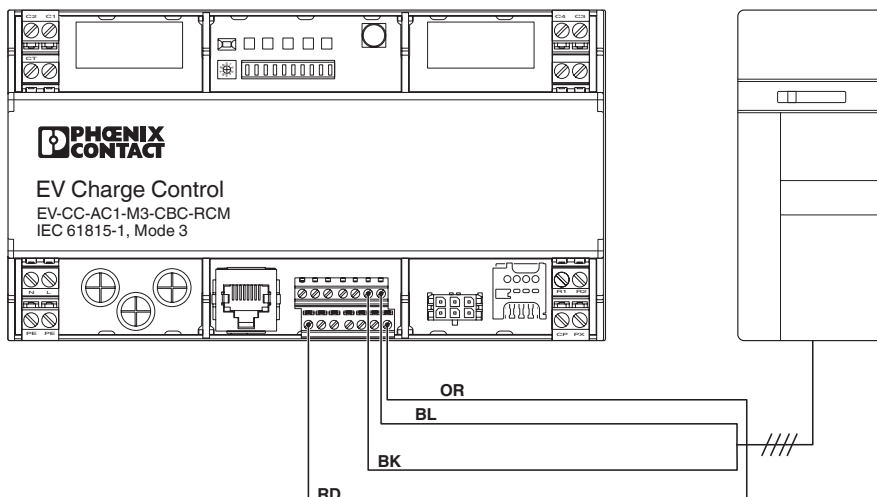

EV-CC-AC1-M3-CBC-RCM-ETH-3G - AC charging controller



1018702

<https://www.phoenixcontact.com/us/products/1018702>

Schematic diagram

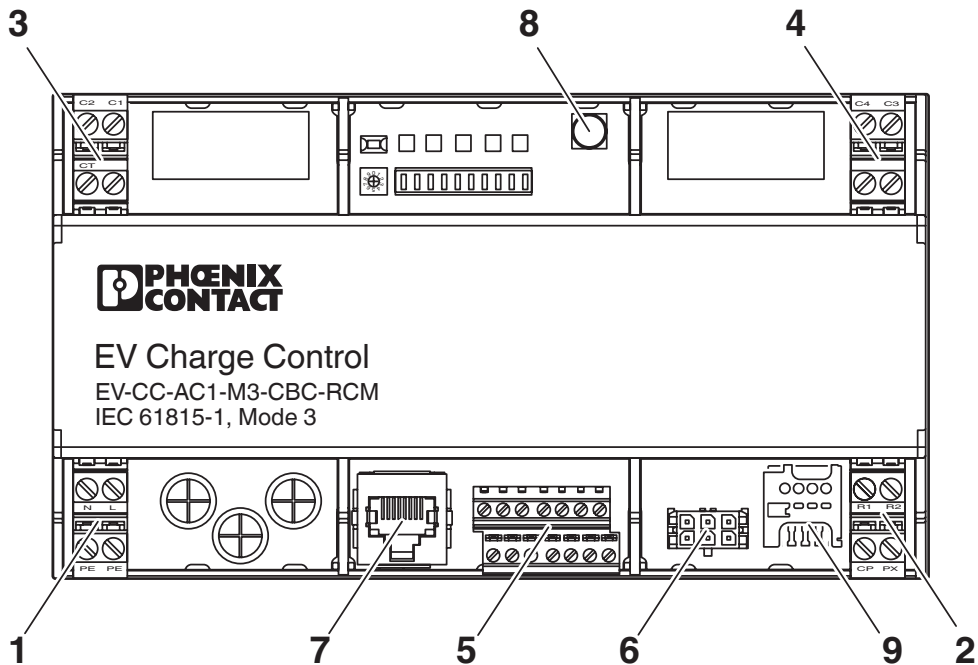

Schematic diagram

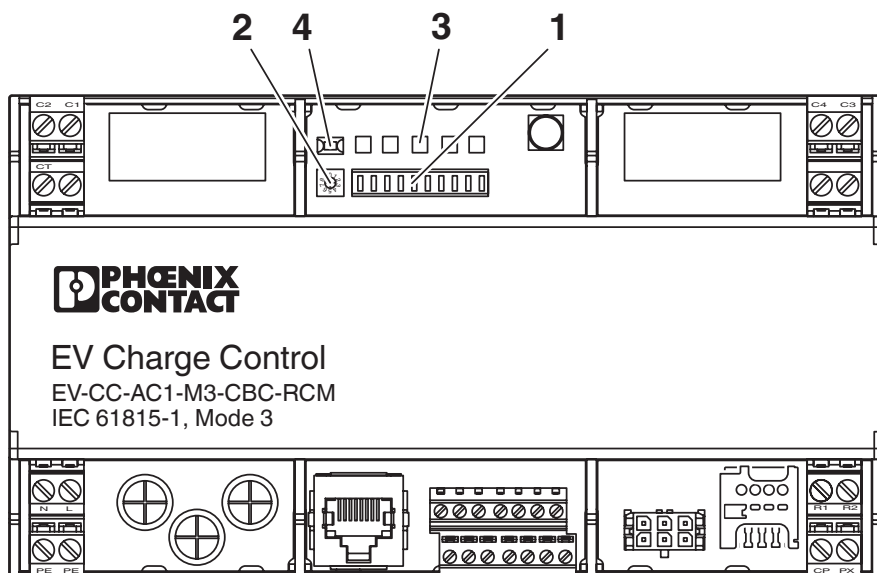

EV-CC-AC1-M3-CBC-RCM-ETH-3G - AC charging controller



1018702

<https://www.phoenixcontact.com/us/products/1018702>

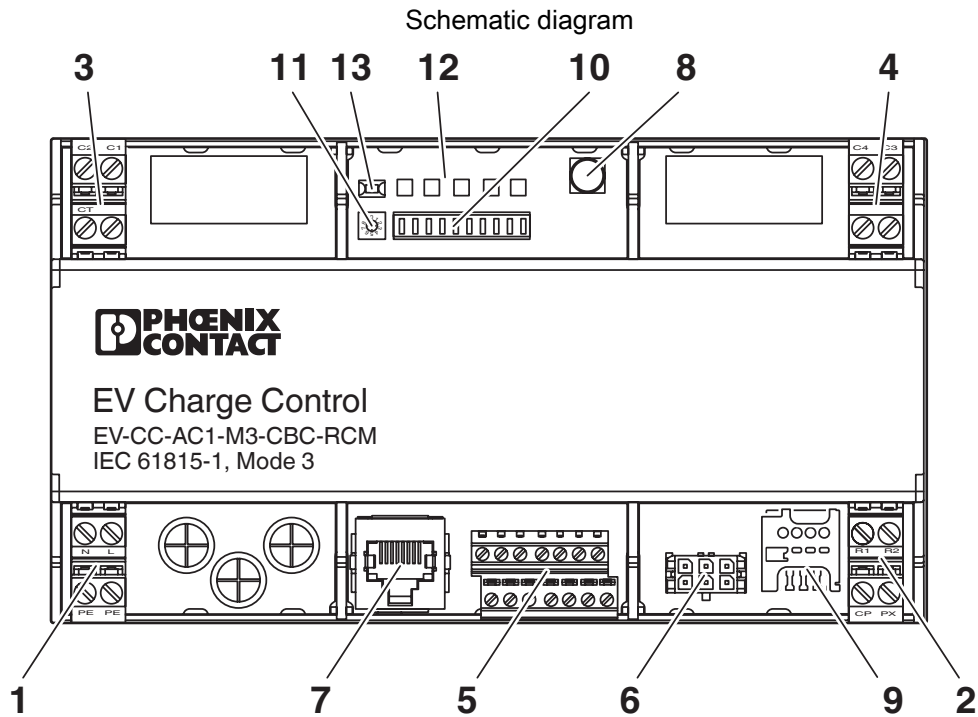

Schematic diagram

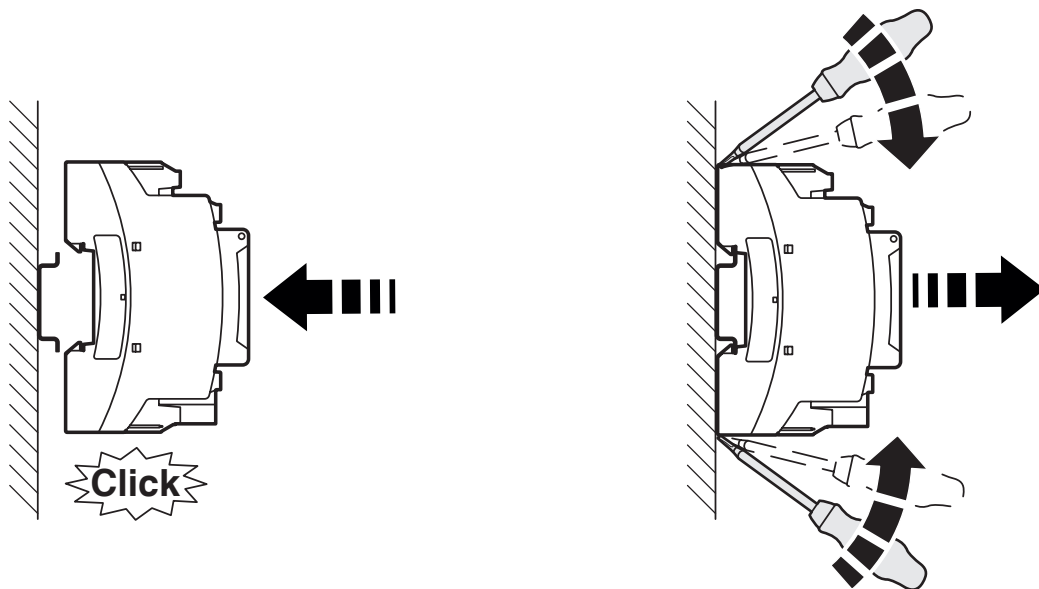

EV-CC-AC1-M3-CBC-RCM-ETH-3G - AC charging controller



1018702

<https://www.phoenixcontact.com/us/products/1018702>

Schematic diagram

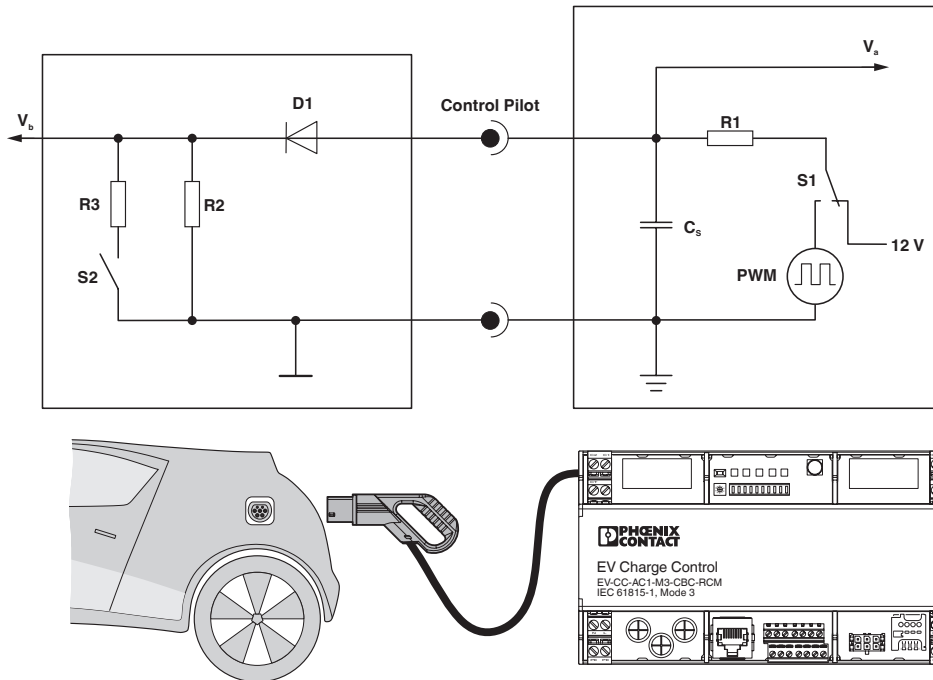

Schematic diagram

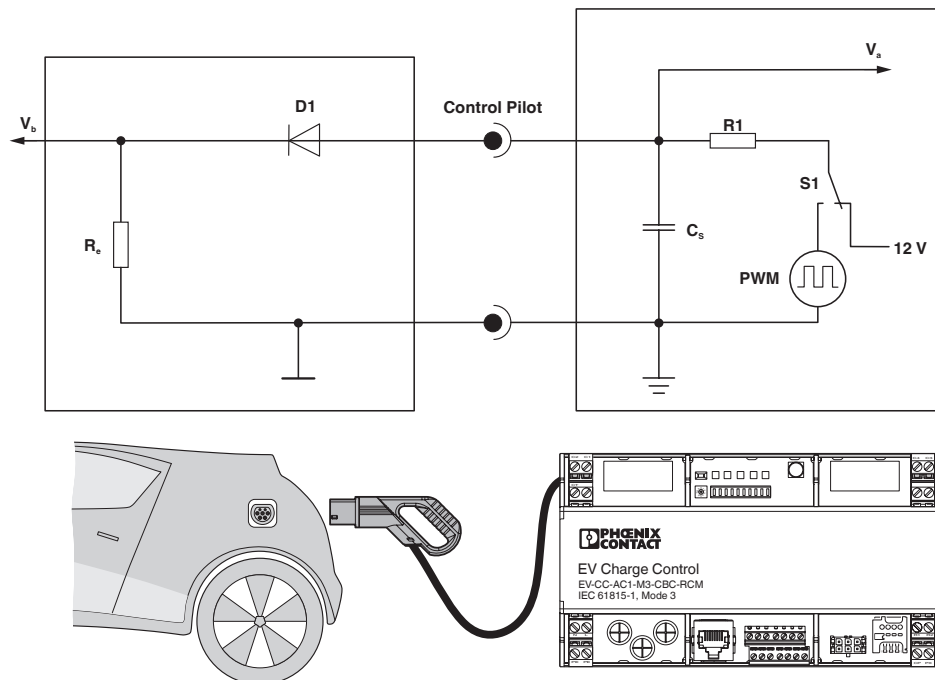

EV-CC-AC1-M3-CBC-RCM-ETH-3G - AC charging controller



1018702

<https://www.phoenixcontact.com/us/products/1018702>

Classifications

ECLASS

ECLASS-15.0	27144703
ECLASS-13.0	27144703

ETIM

ETIM 10.0	EC002889
-----------	----------

UNSPSC

UNSPSC 21.0	39121800
-------------	----------

EV-CC-AC1-M3-CBC-RCM-ETH-3G - AC charging controller



1018702

<https://www.phoenixcontact.com/us/products/1018702>

Environmental product compliance

EU RoHS

Fulfills EU RoHS substance requirements	Yes, No exemptions
---	--------------------

China RoHS

Environment friendly use period (EFUP)	EFUP-E
	No hazardous substances above the limits

EU REACH SVHC

REACH candidate substance (CAS No.)	No substance above 0.1 wt%
-------------------------------------	----------------------------

Phoenix Contact 2026 © - all rights reserved
<https://www.phoenixcontact.com>

Phoenix Contact USA
586 Fulling Mill Road
Middletown, PA 17057, United States
(+717) 944-1300
info@phoenixcon.com