

HC-COM-BWS-PL-BK - Panel mounting base



1012538

<https://www.phoenixcontact.com/us/products/1012538>

Please be informed that the data shown in this PDF document is generated from our online catalog. Please find the complete data in the user documentation. Our general terms of use for downloads are valid.



Panel mounting base COM, with single locking latch, material: PC, height: 20 mm, cable gland: none, Standard

Your advantages

- Lower costs than metal version
- Low weight
- Lower risk of condensation

Commercial data

Item number	1012538
Packing unit	1 pc
Minimum order quantity	1 pc
Sales key	BF59
Product key	AF7APO
GTIN	4055626489193
Weight per piece (including packing)	21.9 g
Weight per piece (excluding packing)	17.9 g
Customs tariff number	85389099
Country of origin	DE

HC-COM-BWS-PL-BK - Panel mounting base



1012538

<https://www.phoenixcontact.com/us/products/1012538>

Technical data

Product properties

Product type	Housing with locking latch
Housing type	Panel mounting base
Product family	HC-COM
Application	Standard
Type	COM
Pg screw connection	none

Dimensions

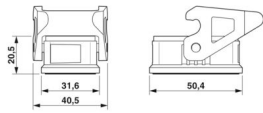
Dimensional drawing	
Width	40.5 mm
Height	20 mm
Length	50.5 mm
Hole diameter	3.5 mm

Installation dimensions

Width of the assembly cutout	22.7 mm
Length of the assembly cutout	26.5 mm

Material specifications

Flammability rating according to UL 94	V0 (Housing)
	V0 (Interlock)
Seal material	NBR
Housing material	PC
Locking latch material	PA

Mechanical properties

Mechanical data

Locking type	Latch
--------------	-------

Connection data

Tightening torque	0.5 Nm ... 0.8 Nm (For M3 mounting screws on the panel-mount base)
-------------------	--

Environmental and real-life conditions

Ambient conditions

Degree of protection	IP66
Impact strength	IK06

HC-COM-BWS-PL-BK - Panel mounting base



1012538

<https://www.phoenixcontact.com/us/products/1012538>

Ambient temperature (operation)

-40 °C ... 125 °C

HC-COM-BWS-PL-BK - Panel mounting base



1012538

<https://www.phoenixcontact.com/us/products/1012538>

Drawings

Dimensional drawing

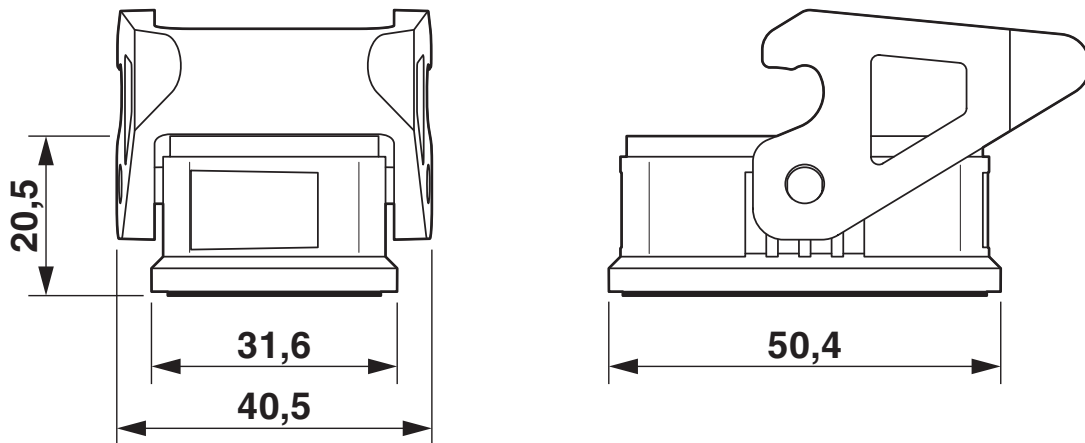

Dimensional drawing

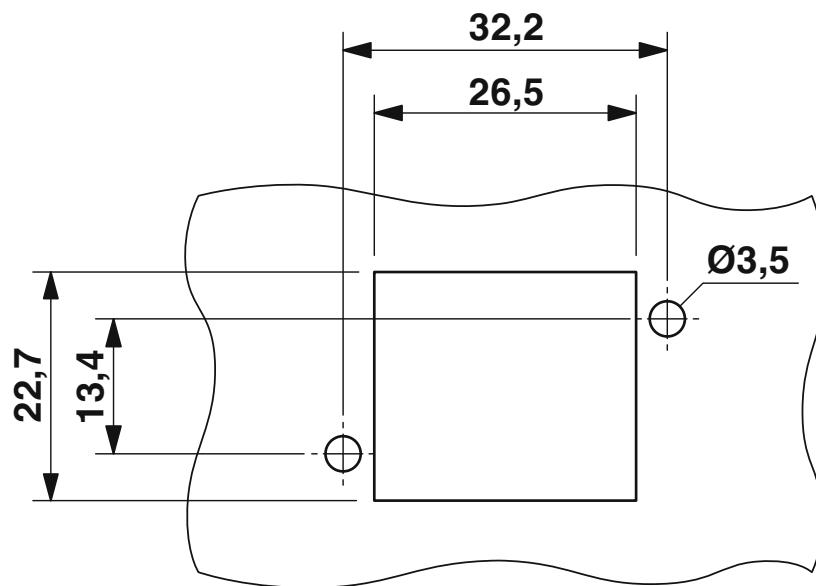

Mounting cutout

HC-COM-BWS-PL-BK - Panel mounting base



1012538

<https://www.phoenixcontact.com/us/products/1012538>

Approvals

To download certificates, visit the product detail page: <https://www.phoenixcontact.com/us/products/1012538>



cUL Recognized
Approval ID: E255026



UL Recognized
Approval ID: E255026



UL Recognized
Approval ID: E468743

HC-COM-BWS-PL-BK - Panel mounting base



1012538

<https://www.phoenixcontact.com/us/products/1012538>

Classifications

ECLASS

ECLASS-13.0	27440202
ECLASS-15.0	27440202

ETIM

ETIM 10.0	EC000437
-----------	----------

UNSPSC

UNSPSC 21.0	31261500
-------------	----------

HC-COM-BWS-PL-BK - Panel mounting base



1012538

<https://www.phoenixcontact.com/us/products/1012538>

Environmental product compliance

EU RoHS

Fulfills EU RoHS substance requirements	Yes, No exemptions
---	--------------------

China RoHS

Environment friendly use period (EFUP)	EFUP-E
	No hazardous substances above the limits

EU REACH SVHC

REACH candidate substance (CAS No.)	2-(2H-benzotriazol-2-yl)-4-(1,1,3,3-tetramethylbutyl)phenol (UV-329)(CAS: 3147-75-9)
SCIP	286f4baa-66d2-4883-b01e-5c14135e300b

EF3.1 Climate Change

CO2e kg	0.271 kg CO2e
---------	---------------

Phoenix Contact 2026 © - all rights reserved
<https://www.phoenixcontact.com>

Phoenix Contact USA
586 Fulling Mill Road
Middletown, PA 17057, United States
(+717) 944-1300
info@phoenixcon.com