

FL SWITCH 2314-2SFP - Industrial Ethernet Switch



1006191

<https://www.phoenixcontact.com/us/products/1006191>

Please be informed that the data shown in this PDF document is generated from our online catalog. Please find the complete data in the user documentation. Our general terms of use for downloads are valid.



The figure shows a version of the product

Managed Switch 2000 series, 14 RJ45 ports 10/100/1000 Mbps, 2 SFP ports 100/1000 Mbps, degree of protection: IP20, Ambient temperature (operation): -40 °C ... 70 °C, Supply voltage range: 12 V DC ... 57 V DC, PROFINET Conformance Class B, Extended temperature range, Development process certified in accordance with IEC 62443-4-1, Product certified in accordance with IEC 62443-4-2

Your advantages

- Ambient temperature -40 °C ... 70 °C
- MRP (client and manager)
- VLANs
- DHCP client, DHCP server (pool-based and port-based), DHCP option 82
- RSTP
- Web-based management, SNMP
- Configuration memory
- Easy and fast startup and commissioning with the FL NETWORK MANAGER software
- Suitable for PROFINET and EtherNet/IP™ networks



Commercial data

| | |
|--------------------------------------|---------------|
| Item number | 1006191 |
| Packing unit | 1 pc |
| Minimum order quantity | 1 pc |
| Sales key | DN17 |
| Product key | DNN121 |
| GTIN | 4055626477503 |
| Weight per piece (including packing) | 588 g |

FL SWITCH 2314-2SFP - Industrial Ethernet Switch



1006191

<https://www.phoenixcontact.com/us/products/1006191>

| | |
|--------------------------------------|----------|
| Weight per piece (excluding packing) | 470 g |
| Customs tariff number | 85176200 |
| Country of origin | DE |

1006191

<https://www.phoenixcontact.com/us/products/1006191>

Technical data

Dimensions

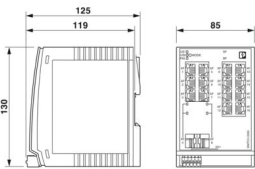
| | |
|---------------------|--|
| Dimensional drawing |  |
| Width | 85 mm |
| Height | 130 mm |
| Depth | 119 mm |

Notes

Utilization restriction

| | |
|----------|---|
| EMC note | EMC: class A product, see manufacturer's declaration in the download area |
|----------|---|

Material specifications

| | |
|------------------|--------------------------------|
| Color (Housing) | gray (RAL 7042) |
| Color (Cover) | light gray (RAL 7035) |
| Housing material | Polycarbonate fiber reinforced |

Mounting

| | |
|---------------|-------------------|
| Mounting type | DIN rail mounting |
|---------------|-------------------|

Interfaces

Ethernet (RJ45)

| | |
|-------------------------------|-----------------------------------|
| Connection method | RJ45 |
| Note on the connection method | Auto negotiation and autocrossing |
| Transmission speed | 10/100/1000 Mbps |
| Transmission physics | Copper |
| Transmission length | 100 m (per segment) |
| Signal LEDs | Data receive, link status |
| No. of channels | 14 (RJ45 ports) |

Ethernet (SFP)

| | |
|----------------------|--|
| Number of interfaces | 2 |
| Connection method | SFP |
| Transmission speed | 100/1000 Mbps (full duplex) |
| Transmission physics | Depending on the SFP module |
| Transmission length | up to 80 km (Depending on the fiber/SFP module used) |
| Signal LEDs | Data receive, link status |

FL SWITCH 2314-2SFP - Industrial Ethernet Switch



1006191

<https://www.phoenixcontact.com/us/products/1006191>

| | |
|-----------------|---------------|
| No. of channels | 2 (SFP ports) |
|-----------------|---------------|

Output data

Digital:

| | |
|-------------|--------------|
| Output name | Alarm output |
|-------------|--------------|

Product properties

| | |
|--------------------|--|
| Product type | Switch |
| Product family | Managed Switch 2000 |
| Type | Book type |
| MTTF | 379.84 Years (SN 29500 standard, temperature 25°C, operating cycle 21%) |
| | 199.41 Years (SN 29500 standard, temperature 40°C, operating cycle 34.25%) |
| | 27.52 Years (SN 29500 standard, temperature 55°C, operating cycle 100%) |
| Special properties | Extended temperature range |
| | Development process certified in accordance with IEC 62443-4-1 |
| | Product certified in accordance with IEC 62443-4-2 |
| Signal delay | ≥ 1.9 μs (Store-and-Forward mode, 10/100/1000 Mbps, depending on the frame size) |

Insulation characteristics

| | |
|---------------------|----------------|
| Protection class | III (VDE 0106) |
| Degree of pollution | 2 |

Switch functions

| | |
|--------------------------------|--|
| Diagnostic functions | RMON History |
| | LLDP (Link Layer Discovery Protocol) |
| | SNMP-Traps |
| | N:1-Portmirroring |
| | ACD (Address Conflict Detection) |
| | SysLog |
| | CRC-Surveillance |
| Basic functions | Store-and-forward switch, complies with IEEE 802.3 |
| Signal contact control voltage | typ. 24 V DC |
| PROFINET conformance class | Conformance Class B |
| PROFINET device function | PROFINET device |
| | Fast Startup |
| Filter functions | Quality of Service (8 priority classes) |
| | Class of Service |
| | DiffServ/DSCP |
| | Port-Priorisierung |
| | VLAN (up to 32 VLANs) |
| | IGMP Snooping/Querier (v1/v2) |
| | Auto-Query-Port |

1006191

<https://www.phoenixcontact.com/us/products/1006191>

| | |
|----------------------------------|---|
| IP parameterization | Extended Multicast Filtering |
| | DHCP client |
| | DHCP Option 82 (Relay Agent) |
| | DHCP server (pool-based, port-based) |
| | BootP |
| | DCP (Discovery and Configuration Protocol) |
| MAC address table | 8k |
| Management | Web-based management (HTTP/HTTPS) |
| | Role-based user management (LDAP, RADIUS) |
| | SNMPv1/v2/v3 |
| | Command Line Interface (Telnet, SSH) |
| Redundancy | MRP (Media Redundancy Protocol) |
| | RSTP (Rapid Spanning Tree Protocol) |
| | FRD (Fast Ring Detection) |
| | Large Tree Support |
| | LACP (Link Aggregation Control Protocol) |
| | PROFINET S2 system redundancy |
| Status and diagnostic indicators | LEDs: US1, US2 (power supply), Fail (alarm contact), 2 LEDs per Ethernet port (Link/Activity and Speed) |
| Additional functions | Jumbo frames (max. 9,600 bytes) |
| | Transmission of MMS and GOOSE (IEC 61850-8-1) |
| | Transmission of Modbus/TCP |
| Time synchronization | SNTP (Simple Network Time Protocol) |
| Security functions | |
| Port security | MAC-based, RADIUS (IEEE 802.1X), MAC Authentication Bypass |
| Basic functions | Store-and-forward switch, complies with IEEE 802.3 |

Electrical properties

| | |
|---|---|
| Current consumption | 325 mA |
| Local diagnostics | US1/2 Supply voltage US1, US2 Green LED |
| | FAIL Div. LED red |
| | LINK Link status Green LED |
| Maximum power dissipation for nominal condition | 15.6 W ($U_S = \text{Min}$, $T_{\text{amb}} = \text{Max}$, $DO_1 = \text{Max}$) |
| Test section | 24 V supply / functional ground 500 V DC 1 min |
| | Ethernet interface/all other potentials 2.25 kV DC 1 min |
| Transmission medium | Copper |
| | FO |

Supply

| | |
|-------------------------|--|
| Supply voltage (DC) | 24 V DC (redundant) |
| Supply voltage range | 12 V DC ... 57 V DC |
| Power supply connection | via COMBICON, max. conductor cross-section 1.5 mm ² |
| Residual ripple | 3.6 V _{PP} (within the permitted voltage range) |

FL SWITCH 2314-2SFP - Industrial Ethernet Switch



1006191

<https://www.phoenixcontact.com/us/products/1006191>

| | |
|-----------------------------|--|
| Max. current consumption | 2 A ($U_S = \text{Min}$, $T_{\text{amb}} = \text{Max}$, $DO_1 = \text{Max}$) |
| Typical current consumption | 460 mA (at $U_S = 24 \text{ V DC}$ and 25 °C ambient temperature) |
| Current consumption | 325 mA |

Function

| | |
|--------------------------------|--------------|
| Signal contact control voltage | typ. 24 V DC |
|--------------------------------|--------------|

Connection data

| | |
|-----------------------------------|--|
| Connection method | Push-in spring connection |
| Note on the connection method | Use only copper connecting cables providing the permitted temperature range ($-40 \text{ °C} \dots 75 \text{ °C}$) |
| pluggable | yes |
| Conductor cross-section, rigid | $0.25 \text{ mm}^2 \dots 1.5 \text{ mm}^2$ |
| Conductor cross-section, flexible | $0.25 \text{ mm}^2 \dots 1.5 \text{ mm}^2$ |
| Conductor cross-section AWG | 24 ... 16 |
| Stripping length | 9 mm |

Environmental and real-life conditions

Ambient conditions

| | |
|--|---|
| Degree of protection | IP20 |
| Ambient temperature (operation) | $-40 \text{ °C} \dots 70 \text{ °C}$ |
| Ambient temperature (storage/transport) | $-40 \text{ °C} \dots 85 \text{ °C}$ |
| Permissible humidity (operation) | 10 % ... 95 % (non-condensing) |
| Permissible humidity (storage/transport) | 10 % ... 95 % (non-condensing) |
| Shock (operation) | 30g (EN 60068-2-27) |
| Vibration (operation) | in acc. with IEC 60068-2-6: 5g, 150 Hz |
| Air pressure (operation) | 80 kPa ... 110 kPa up to 2000 m above mean sea level (Without derating) |
| Air pressure (storage/transport) | 79 kPa ... 108 kPa up to 2000 m above mean sea level (Without derating) |

Standards and regulations

| | |
|---|-----|
| Free from substances that could impair the application of coating | Yes |
|---|-----|

Approvals

| | |
|-----------------------|--|
| Shipbuilding approval | Tested in accordance with IEC 60945 and IACS E10 |
|-----------------------|--|

ATEX

| | |
|----------------|--------------------------|
| Identification | Ⓜ II 3 G Ex ec IIC T4 Gc |
| Certificate | DEMKO 16 ATEX 1709X |

IECEX

| | |
|----------------|---------------------|
| Identification | Ex ec IIC T4 Gc |
| Certificate | IECEX ULD 16.0018 X |

UL, USA/Canada

| | |
|----------------|-------|
| Identification | cULus |
|----------------|-------|

FL SWITCH 2314-2SFP - Industrial Ethernet Switch



1006191

<https://www.phoenixcontact.com/us/products/1006191>

UL Ex, USA / Canada

| | |
|----------------|---|
| Identification | Class I, Division 2, Groups A, B, C, and D, T4 |
| | Class I, Zone 2, AEx ec IIC T4 |
| | Ex ec IIC T4 Gc X |
| Certificate | E366272 |
| Note | UL 60079-0 Ed. 6 / UL 60079-7 Ed. 5, CSA 22.2 No. 60079-0 Ed. 3 / CSA C22.2 No. 60079-7 Ed. 2 |

EAC Ex

| | |
|----------------|-------------------------|
| Identification | 2Ex e IIC T4 Gc X |
| Certificate | RU C-DE.HB49.B.00118/21 |

The following continue to apply for EAC Ex:

| | |
|----------------|---|
| Identification | Install the device in a suitable, approved housing with at least IP66 protection. |
| | The housing/control cabinet must be equipped with a warning sign prohibiting opening in the potentially explosive area. |
| | The operation of devices is permitted if all optical ports are connected or sealed with the supplied filler plugs. |

CCC / China-Ex

| | |
|----------------|------------------|
| Identification | Ex ec IIC T4 Gc |
| Certificate | 2022122310115629 |

Corrosive gas test

| | |
|----------------|----------------------------------|
| Identification | ISA S71.04.2013 G3 Harsh Group A |
|----------------|----------------------------------|

UKCA Ex (UKEX)

| | |
|----------------|--------------------------|
| Identification | ⊕ II 3 G Ex ec IIC T4 Gc |
| Certificate | PxCIMA22UKEX2702910X |

Shipbuilding data

| | |
|-------------|---|
| Temperature | B |
| Humidity | B |
| Vibration | A |
| EMC | B |
| Enclosure | Required protection according to the Rules shall be provided upon installation on board |

EMC data

| | |
|---------------------------------|--|
| Electromagnetic compatibility | Conformance with EMC Directive 2014/30/EU |
| Conformance with EMC directives | EN 61000-6-2 EN 61000-4-2 (ESD) Criterion B |
| | EN 61000-6-2 EN 61000-4-3 (electromagnetic fields) Criterion A |
| | EN 61000-6-2 EN 61000-4-4 (EFT burst) Criterion A |
| | EN 61000-6-2 EN 61000-4-5 (surge) Criterion A |
| | EN 61000-6-2 EN 61000-4-6 (line noise immunity) Criterion A |
| | EN 61000-6-2 EN 61000-6-3 (noise emission) Class B |
| | EN 61000-6-2 EN 61000-6-3 (conducted emissions) Class B |

FL SWITCH 2314-2SFP - Industrial Ethernet Switch



1006191

<https://www.phoenixcontact.com/us/products/1006191>

| | |
|----------------|--------------|
| Noise immunity | EN 61000-6-2 |
|----------------|--------------|

Noise emission

| | |
|-----------------------|--------------|
| Standards/regulations | EN 61000-6-4 |
|-----------------------|--------------|

System properties

Functionality

| | |
|-----------------|--|
| Basic functions | Store-and-forward switch, complies with IEEE 802.3 |
|-----------------|--|

Signaling

| | |
|----------------|---|
| Status display | LEDs: US1, US2 (power supply), Fail (alarm contact), 2 LEDs per Ethernet port (Link/Activity and Speed) |
|----------------|---|

FL SWITCH 2314-2SFP - Industrial Ethernet Switch



1006191

<https://www.phoenixcontact.com/us/products/1006191>

Drawings

Dimensional drawing

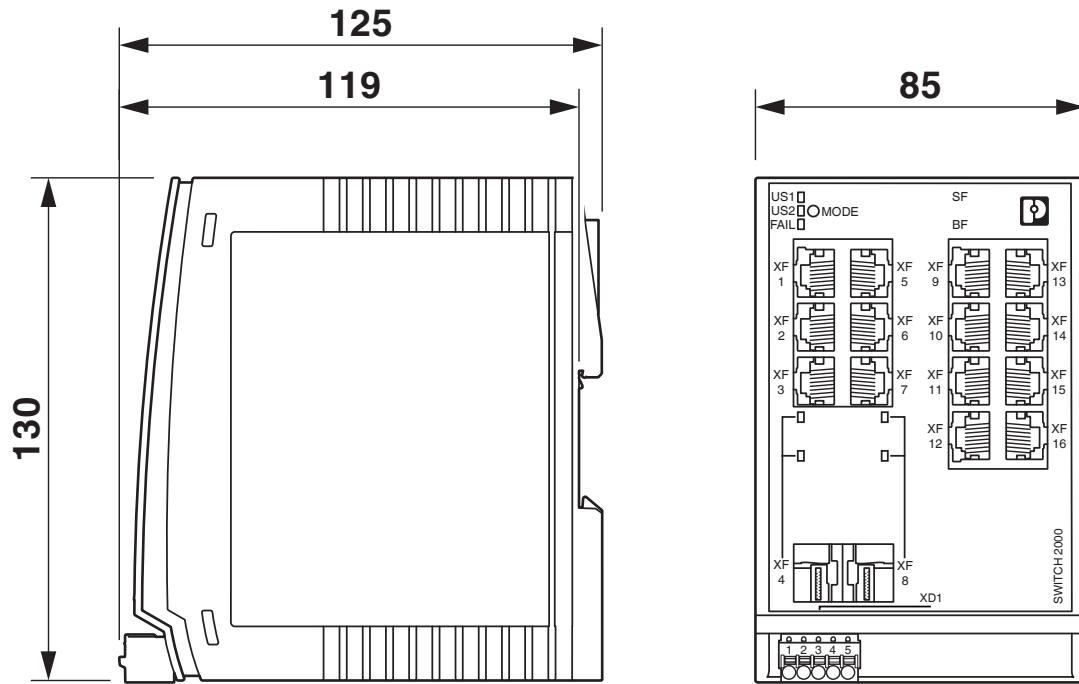

FL SWITCH 2314-2SFP - Industrial Ethernet Switch



1006191

<https://www.phoenixcontact.com/us/products/1006191>

Approvals

🔗 To download certificates, visit the product detail page: <https://www.phoenixcontact.com/us/products/1006191>



DNV GL

Approval ID: TAA00000YV



LR

Approval ID: LR22250919TA



NK

Approval ID: TA24215M



BV

Approval ID: 48146_B1 BV

BSH

Approval ID: 1045



RINA

Approval ID: ELE014724XG001

ABS

Approval ID: 21_2066186_1_PDA



cULus Listed

Approval ID: E238705



CC-Link IE Field

Approval ID: Ref. No. 184

Cybersecurity Certificate

Approval ID: 968 CSP 1043.00 25

ABS

Approval ID: 21_2066186_1_PDA

FL SWITCH 2314-2SFP - Industrial Ethernet Switch



1006191

<https://www.phoenixcontact.com/us/products/1006191>

BSH

Approval ID: 1045



BV

Approval ID: 48146_B1 BV



DNV GL

Approval ID: TAA00000YV



NK

Approval ID: TA24215M



RINA

Approval ID: ELE014724XG001



LR

Approval ID: LR22250919TA



cULus Listed

Approval ID: E238705



CC-Link IE Field

Approval ID: Ref. No. 184

Cybersecurity Certificate

Approval ID: 968 CSP 1043.00 25



IECEX

Approval ID: IECEX ULD 16.0018X



ATEX

Approval ID: DEMKO 16 ATEX 1709X



CCC

Approval ID: 2022122310115629

FL SWITCH 2314-2SFP - Industrial Ethernet Switch



1006191

<https://www.phoenixcontact.com/us/products/1006191>



CCC

Approval ID: 2022122310115629



IECEX

Approval ID: IECEX ULD 16.0018X



ATEX

Approval ID: DEMKO 16 ATEX 1709X



cULus Listed

Approval ID: E366272



cULus Listed

Approval ID: E366272

FL SWITCH 2314-2SFP - Industrial Ethernet Switch



1006191

<https://www.phoenixcontact.com/us/products/1006191>

Classifications

ECLASS

| | |
|-------------|----------|
| ECLASS-13.0 | 19170401 |
| ECLASS-15.0 | 19170401 |

ETIM

| | |
|-----------|----------|
| ETIM 10.0 | EC000734 |
|-----------|----------|

UNSPSC

| | |
|-------------|----------|
| UNSPSC 21.0 | 43222600 |
|-------------|----------|

1006191

<https://www.phoenixcontact.com/us/products/1006191>

Environmental product compliance

EU RoHS

| | |
|---|--------------|
| Fulfills EU RoHS substance requirements | Yes |
| Exemption | 7(a), 7(c)-I |

China RoHS

| | |
|--|---|
| Environment friendly use period (EFUP) | EFUP-50 |
| | An article-related China RoHS declaration table can be found in the download area for the respective article under "Manufacturer declaration". For all articles with EFUP-E, no China RoHS declaration table issued and required. |

EU REACH SVHC

| | |
|-------------------------------------|--------------------------------------|
| REACH candidate substance (CAS No.) | Lead(CAS: 7439-92-1) |
| SCIP | 3ce1cfd5-ee09-4440-a9ff-ff1ed6832044 |

Phoenix Contact 2026 © - all rights reserved

<https://www.phoenixcontact.com>

Phoenix Contact USA
586 Fulling Mill Road
Middletown, PA 17057, United States
(+717) 944-1300
info@phoenixcon.com