

NS 35/15 WH PERF(5,2X25)2000MM-VPE 10 - DIN rail perforated



0843114

<https://www.phoenixcontact.com/us/products/0843114>

Please be informed that the data shown in this PDF document is generated from our online catalog. Please find the complete data in the user documentation. Our general terms of use for downloads are valid.



DIN rail perforated, Pack of 10 (20 m), similar to EN 60715, material: Steel, galvanized, white passivated, Standard profile, color: silver-colored

Commercial data

Item number	0843114
Packing unit	10 m
Minimum order quantity	20 m
Sales key	BE72
Product key	BE7238
GTIN	4046356949156
Weight per piece (including packing)	1,305 g
Weight per piece (excluding packing)	1,305 g
Customs tariff number	72166190
Country of origin	DE

NS 35/15 WH PERF(5,2X25)2000MM-VPE 10 - DIN rail perforated



0843114

<https://www.phoenixcontact.com/us/products/0843114>

Technical data

Product properties

Product type	DIN rail
--------------	----------

Dimensions

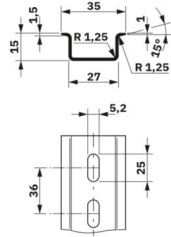
Dimensional drawing	
Width	35 mm
Hole width	25 mm
Hole height	5.2 mm
Depth	15 mm
Length	2000 mm
Drill hole spacing	36 mm

Material specifications

Color	silver-colored
Material	Steel
Coating	galvanized, white passivated

Standards and regulations

Connection in acc. with standard	IEC / EN
Tests	similar to EN 60715

Electrical tests

Short-time withstand current

Equivalent E-Cu cross-section	25 mm ²
Short-time current resistance 1s	3 kA

NS 35/15 WH PERF(5,2X25)2000MM-VPE 10 - DIN rail perforated



0843114

<https://www.phoenixcontact.com/us/products/0843114>

Drawings

Dimensional drawing

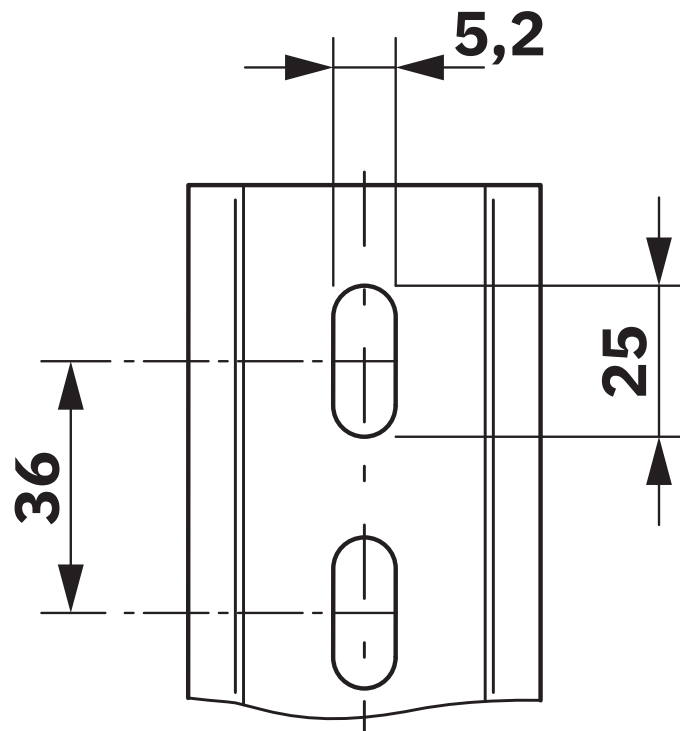
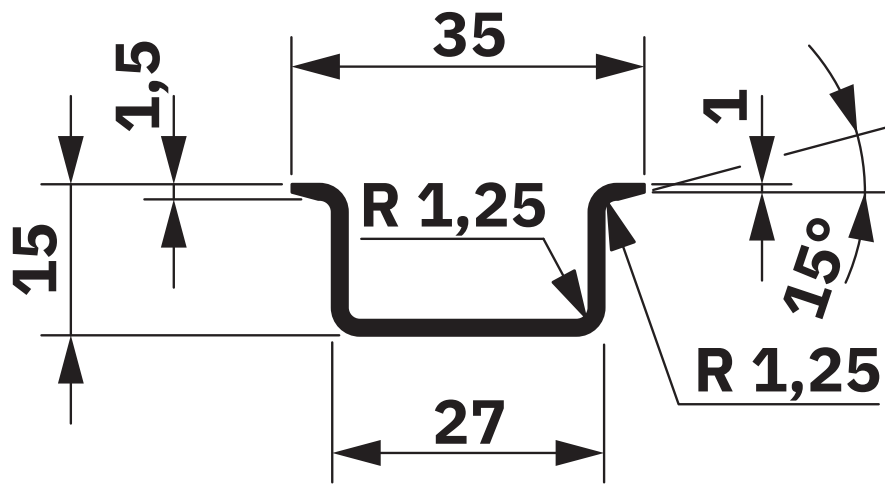

NS 35/15 WH PERF(5,2X25)2000MM-VPE 10 - DIN rail perforated



0843114

<https://www.phoenixcontact.com/us/products/0843114>

Classifications

ECLASS

ECLASS-15.0	27400602
ECLASS-13.0	27400602

ETIM

ETIM 10.0	EC001285
-----------	----------

UNSPSC

UNSPSC 21.0	39121700
-------------	----------

NS 35/15 WH PERF(5,2X25)2000MM-VPE 10 - DIN rail perforated



0843114

<https://www.phoenixcontact.com/us/products/0843114>

Environmental product compliance

EU RoHS

Fulfills EU RoHS substance requirements	Yes, No exemptions
-----------------------------------------	--------------------

China RoHS

Environment friendly use period (EFUP)	EFUP-E
	No hazardous substances above the limits

EU REACH SVHC

REACH candidate substance (CAS No.)	No substance above 0.1 wt%
-------------------------------------	----------------------------

EF3.1 Climate Change

CO2e kg	2.718 kg CO2e
---------	---------------

Phoenix Contact 2026 © - all rights reserved
<https://www.phoenixcontact.com>

Phoenix Contact USA
586 Fulling Mill Road
Middletown, PA 17057, United States
(+717) 944-1300
info@phoenixcon.com