

# NS 35/15 WH PERF 2000MM VPE 10 - DIN rail perforated



0843108

<https://www.phoenixcontact.com/us/products/0843108>

Please be informed that the data shown in this PDF document is generated from our online catalog. Please find the complete data in the user documentation. Our general terms of use for downloads are valid.



DIN rail perforated, Pack of 10 (20 m), similar to EN 60715, material: Steel, galvanized, white passivated, Standard profile, color: white

## Commercial data

Item number	0843108
Packing unit	10 m
Minimum order quantity	20 m
Sales key	BE72
Product key	BE7238
GTIN	4046356949095
Weight per piece (including packing)	1,265 g
Weight per piece (excluding packing)	1,265 g
Customs tariff number	72166190
Country of origin	DE

# NS 35/15 WH PERF 2000MM VPE 10 - DIN rail perforated



0843108

<https://www.phoenixcontact.com/us/products/0843108>

## Technical data

### Product properties

Product type	DIN rail
--------------	----------

### Dimensions

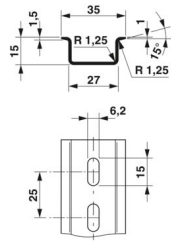
Dimensional drawing	
Width	35 mm
Hole width	15 mm
Hole height	6.2 mm
Depth	15 mm
Length	2000 mm
Drill hole spacing	25 mm

### Material specifications

Color	white (RAL 9010)
Material	Steel
Coating	galvanized, white passivated

### Standards and regulations

Connection in acc. with standard	IEC / EN
Tests	similar to EN 60715

### Electrical tests

Short-time withstand current	
Equivalent E-Cu cross-section	25 mm <sup>2</sup>
Short-time current resistance 1s	3 kA

# NS 35/15 WH PERF 2000MM VPE 10 - DIN rail perforated



0843108

<https://www.phoenixcontact.com/us/products/0843108>

## Drawings

Dimensional drawing



# NS 35/15 WH PERF 2000MM VPE 10 - DIN rail perforated



0843108

<https://www.phoenixcontact.com/us/products/0843108>

## Classifications

### ECLASS

ECLASS-13.0	27400602
ECLASS-15.0	27400602

### ETIM

ETIM 10.0	EC001285
-----------	----------

### UNSPSC

UNSPSC 21.0	39121700
-------------	----------

# NS 35/15 WH PERF 2000MM VPE 10 - DIN rail perforated



0843108

<https://www.phoenixcontact.com/us/products/0843108>

## Environmental product compliance

### EU RoHS

Fulfills EU RoHS substance requirements	Yes, No exemptions
---	--------------------

### China RoHS

Environment friendly use period (EFUP)	EFUP-E
	No hazardous substances above the limits

### EU REACH SVHC

REACH candidate substance (CAS No.)	No substance above 0.1 wt%
-------------------------------------	----------------------------

### EF3.1 Climate Change

CO2e kg	2.763 kg CO2e
---------	---------------

Phoenix Contact 2026 © - all rights reserved  
<https://www.phoenixcontact.com>

Phoenix Contact USA  
586 Fulling Mill Road  
Middletown, PA 17057, United States  
(+717) 944-1300  
[info@phoenixcon.com](mailto:info@phoenixcon.com)