

LS-EMSP-V4A (75,6X54) - Device marker



0831656

<https://www.phoenixcontact.com/us/products/0831656>

Please be informed that the data shown in this PDF document is generated from our online catalog. Please find the complete data in the user documentation. Our general terms of use for downloads are valid.

Device marker, Stainless steel label, unmarked, can be labeled with: TOPMARK NEO, TOPMARK LASER, mounting type: screw, rivet, Number of individual labels: 6, text field height: 54 mm, text field width: 75.6 mm



Your advantages

- Stainless steel device marking for screwing or riveting
- Easy-to-clean and permanent identification that also meets stringent hygiene requirements
- High resistance to corrosion, acids, and temperatures

Commercial data

Item number	0831656
Packing unit	5 pc
Minimum order quantity	5 pc
Sales key	BG19
Product key	BG241D
GTIN	4046356925952
Weight per piece (including packing)	156.1 g
Weight per piece (excluding packing)	148.97 g
Customs tariff number	73269098
Country of origin	CN

Technical data

Product properties

Product type	Device marker
--------------	---------------

Marking

Number of individual labels	6
Identification technology	Direct laser marking

Dimensions

Width	85.00 mm
Height	53.70 mm
Depth	0.50 mm

Text field

Text field width	75.6 mm
Text field height	54 mm

Material specifications

RoHS compliant	yes
Color	silver-colored
Material	V4A (1.4404; AISI 316L)
Base element material	V4A (1.4404; AISI 316L)
Components	free from silicone, halogen, and cadmium

Environmental and real-life conditions

Ambient conditions

Ambient temperature (operation)	-80 °C ... 350 °C
Recommended ambient temperature (storage/transport)	23 °C
Recommended humidity (storage/transport)	50 %

Test for substances that would hinder coating with paint or varnish

Testing for paint wetting impairment substances (LABS-conformity)	VDMA 24364-A1-L:2018-05
Result	Test passed

Scratch resistance

Specification	EN ISO 1518-1:2023 (following)
---------------	--------------------------------

Tesafilm test

Specification	DIN EN ISO 2409:2020-12 (following)
Result	Test passed

UV resistance

Specification	DIN EN ISO 4892-2:2021-11 (following)
Result	Test passed

LS-EMSP-V4A (75,6X54) - Device marker



0831656

<https://www.phoenixcontact.com/us/products/0831656>

Test duration	96 h
Procedure	Artificial irradiation.

Temperature storage

Specification	IEC 60068-2-2:2007-07
Result	Test passed
Procedure	Test Bb
Duration	240 h
Temperature for testing	350 °C

Temperature resistance

Specification	ANSI/UL 969-2018:03 (following)
Test duration	240 h
Rating 225 °C (250 °C)	Test passed

Wipe resistance of inscriptions

Specification	DIN EN 61010-1 (VDE 0411-1):2011-07 DIN EN 62208 (VDE 0660-511):2012-06 (in parts)
Isopropanol (99%) [67-63-0]	Test passed
n-Hexane [CAS No. 110-54-3]	Test passed
Water + Petroleum ether [CAS No. 64742-82-1]	Test passed
Sodium hydroxide 0.1 mol/l [CAS No. 1310-73-2]	Test passed
Ethanol (99 %) [CAS No. 64-17-5]	Test passed
Acetone (99 %) [CAS No. 67-64-1]	Test passed

Immersion in chemicals, oil & fuel

Specification	ISO 175:2010 (following)
Test duration	168 h
Saltwater (saturated 350 g/l) [CAS No. -]	Test passed
Ethanol (99 %) [CAS No. 64-17-5]	Test passed
Acetone (99 %) [CAS No. 67-64-1]	Test passed
Methylethylketone (MEK) [CAS No. 78-93-3]	Test passed
IRM 901	Test passed
IRM 902	Test passed
IRM 903	Test passed

Testing in a condensation changing climate in the presence of sulfur dioxide

Specification	DIN EN ISO 22479:2022-08
Result	Test passed
Procedure	Method B

LS-EMSP-V4A (75,6X54) - Device marker



0831656

<https://www.phoenixcontact.com/us/products/0831656>

Cycles	2
--------	---

Salt spray test

Specification	DIN EN IEC 60068-2-11 (VDE 0468-2-11):2022-10
Result	Test passed
Test duration	96 h

Salt spray test

Specification	ISO 9227:2017-03
Result	Test passed
Test duration	336 h

Standards and regulations

Wipe resistance	DIN EN 61010-1 (VDE 0411-1)
-----------------	-----------------------------

Mounting

Mounting type	screw, rivet
---------------	--------------

LS-EMSP-V4A (75,6X54) - Device marker



0831656

<https://www.phoenixcontact.com/us/products/0831656>

Drawings

Dimensional drawing

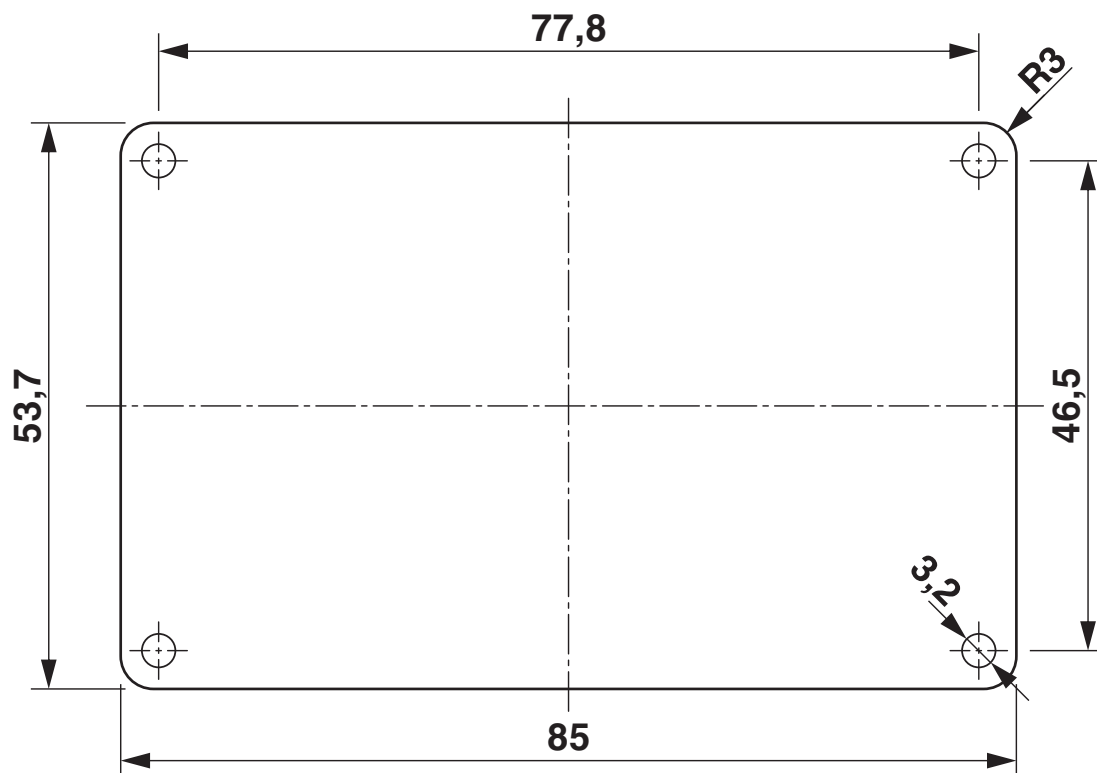

LS-EMSP-V4A (75,6X54) - Device marker



0831656

<https://www.phoenixcontact.com/us/products/0831656>

Classifications

ECLASS

ECLASS-13.0	27281103
ECLASS-15.0	27281103

ETIM

ETIM 10.0	EC001288
-----------	----------

UNSPSC

UNSPSC 21.0	39131500
-------------	----------

LS-EMSP-V4A (75,6X54) - Device marker



0831656

<https://www.phoenixcontact.com/us/products/0831656>

Environmental product compliance

EU RoHS

Fulfills EU RoHS substance requirements	Yes, No exemptions
---	--------------------

EU REACH SVHC

REACH candidate substance (CAS No.)	No substance above 0.1 wt%
-------------------------------------	----------------------------

Phoenix Contact 2026 © - all rights reserved

<https://www.phoenixcontact.com>

Phoenix Contact USA
586 Fulling Mill Road
Middletown, PA 17057, United States
(+717) 944-1300
info@phoenixcon.com