

E/NS 35 N - End bracket

0800886

<https://www.phoenixcontact.com/us/products/0800886>

Please be informed that the data shown in this PDF document is generated from our online catalog. Please find the complete data in the user documentation. Our general terms of use for downloads are valid.

End clamp, width: 9.5 mm, color: gray

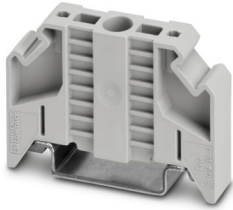

Your advantages

- Large-surface marking

Commercial data

Item number	0800886
Packing unit	50 pc
Minimum order quantity	50 pc
Sales key	BE07
Product key	BE7111
GTIN	4017918129309
Weight per piece (including packing)	14.16 g
Weight per piece (excluding packing)	14.08 g
Customs tariff number	39269097
Country of origin	DE

Technical data

Product properties

Product type	End bracket
--------------	-------------

Connection data

Screw thread	M3
Tightening torque	0.6 ... 0.8 Nm

Dimensions

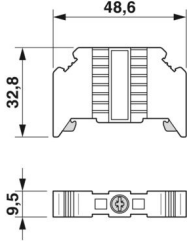
Dimensional drawing	
Width	9.5 mm
Height	48.6 mm
Depth	32.8 mm
Depth on NS 35/7,5	34.3 mm
Length	48.6 mm

Material specifications

Color	gray (RAL 7042)
Material	PA
Flammability rating according to UL 94	V0
Static insulating material application in cold	-60 °C
Temperature index of insulation material (DIN EN 60216-1 (VDE 0304-21))	125 °C
Relative insulation material temperature index (Elec., UL 746 B)	130 °C

Environmental and real-life conditions

Ambient conditions

Ambient temperature (operation)	-60 °C ... 105 °C (max. short-term operating temperature RTI Elec.)
Ambient temperature (storage/transport)	-25 °C ... 60 °C (for a short time, not exceeding 24 h, -60 °C to +70 °C)
Ambient temperature (assembly)	-5 °C ... 70 °C
Ambient temperature (actuation)	-5 °C ... 70 °C
Permissible humidity (storage/transport)	30 % ... 70 %

Mounting

E/NS 35 N - End bracket

0800886

<https://www.phoenixcontact.com/us/products/0800886>



Mounting type	NS 35/7,5
	NS 35/15

E/NS 35 N - End bracket

0800886

<https://www.phoenixcontact.com/us/products/0800886>



Drawings

Dimensional drawing

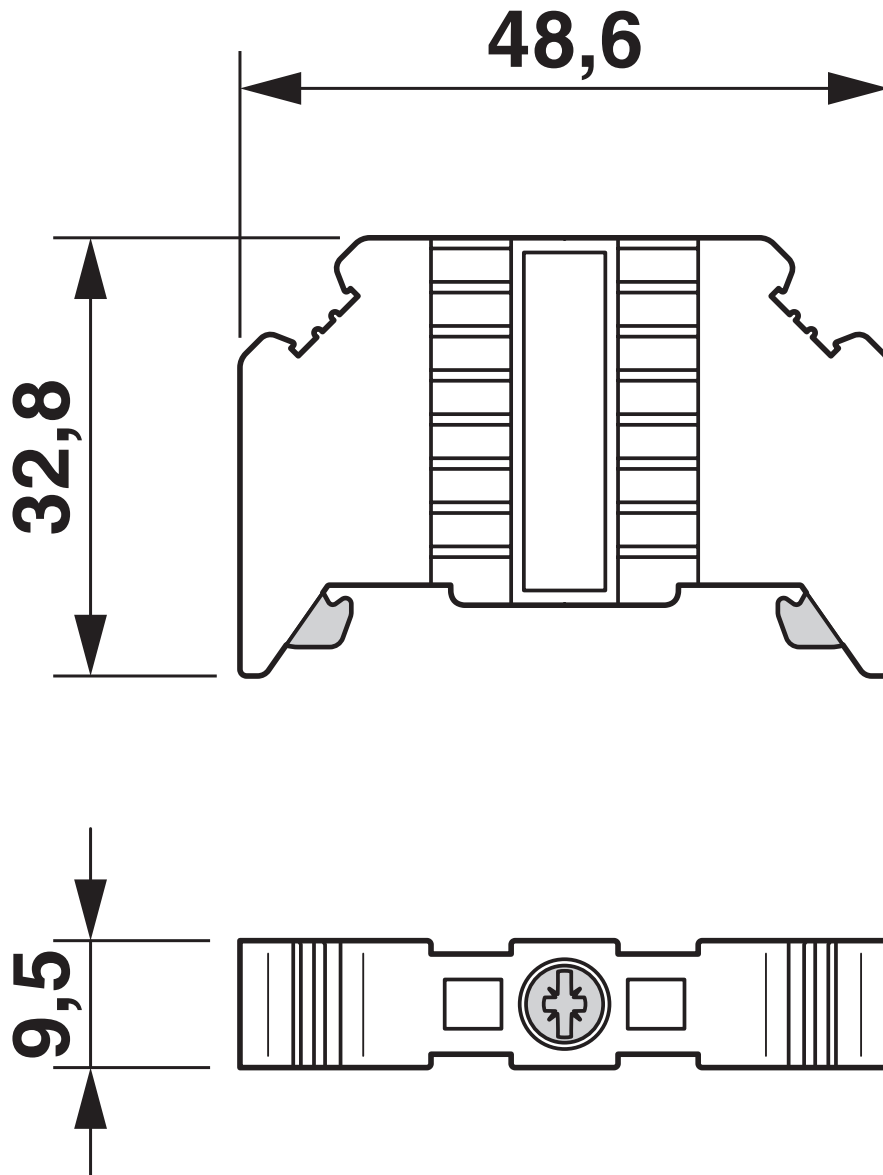

E/NS 35 N - End bracket



0800886

<https://www.phoenixcontact.com/us/products/0800886>

Classifications

ECLASS

ECLASS-13.0	27250302
ECLASS-15.0	27250302

ETIM

ETIM 10.0	EC001041
-----------	----------

UNSPSC

UNSPSC 21.0	39121400
-------------	----------

E/NS 35 N - End bracket



0800886

<https://www.phoenixcontact.com/us/products/0800886>

Environmental product compliance

EU RoHS

Fulfills EU RoHS substance requirements	Yes, No exemptions
-----------------------------------------	--------------------

China RoHS

Environment friendly use period (EFUP)	EFUP-E
	No hazardous substances above the limits

EU REACH SVHC

REACH candidate substance (CAS No.)	No substance above 0.1 wt%
-------------------------------------	----------------------------

EF3.1 Climate Change

CO2e kg	0.031 kg CO2e
---------	---------------

Phoenix Contact 2026 © - all rights reserved
<https://www.phoenixcontact.com>

Phoenix Contact USA
586 Fulling Mill Road
Middletown, PA 17057, United States
(+717) 944-1300
info@phoenixcon.com