

DFK/DP-2,8-FRONT 2,5 - Panel feed-through terminal block



0706524

<https://www.phoenixcontact.com/us/products/0706524>

Please be informed that the data shown in this PDF document is generated from our online catalog. Please find the complete data in the user documentation. Our general terms of use for downloads are valid.



The figure shows version DFK-2,8 FRONT 2,5

Panel feed-through terminal block, connection method: Screw connection with tension sleeve, Solder/Slip-on connection, number of positions: 1, load current: 18 A, cross section: 0.2 mm² - 4 mm², connection direction of the conductor to plug-in direction: 0 °, width: 6.15 mm, color: gray

Your advantages

- Well-known connection principle allows worldwide use
- Low temperature rise, thanks to maximum contact force
- Allows connection of two conductors
- Tool-free snap-in principle enables easy mounting on the device panel

Commercial data

Item number	0706524
Packing unit	50 pc
Minimum order quantity	50 pc
Sales key	AA28
Product key	AA1ABB
GTIN	4017918003739
Weight per piece (including packing)	7.794 g
Weight per piece (excluding packing)	7.794 g
Customs tariff number	85369010
Country of origin	BG

DFK/DP-2,8-FRONT 2,5 - Panel feed-through terminal block



0706524

<https://www.phoenixcontact.com/us/products/0706524>

Technical data

Product properties

Product type	Panel feed-through terminal block
Product family	DFK-2,8-FRONT
Number of positions	1
Pitch	6 mm
Number of connections	2
Number of rows	1
Number of potentials	1

Insulation characteristics

Overvoltage category	III
Degree of pollution	3

Electrical properties

Properties

Nominal current I_N	17.5 A
Nominal voltage U_N	400 V
Rated voltage (III/3)	400 V
Rated surge voltage (III/3)	4 kV

Connection data

Connection technology

Nominal cross section	2.5 mm ²
-----------------------	---------------------

Conductor connection exterior

Connection method	Screw connection with tension sleeve
Connection direction of the conductor to plug-in direction	0 °
Conductor cross-section rigid	0.2 mm ² ... 4 mm ²
Conductor cross-section flexible	0.2 mm ² ... 2.5 mm ²
Conductor cross-section, flexible, with ferrule, without plastic sleeve	0.25 mm ² ... 2.5 mm ²
Conductor cross-section, flexible, with ferrule, with plastic sleeve	0.25 mm ² ... 2.5 mm ²
2 conductors with same cross section, rigid	0.2 mm ² ... 1 mm ²
2 conductors with same cross section, flexible	0.2 mm ² ... 1.5 mm ²
2 conductors with same cross section, flexible, with ferrule without plastic sleeve	0.5 mm ² ... 0.75 mm ²
Internal cylindrical gage	A3
Stripping length	14 mm
Tightening torque	0.8 Nm ... 1 Nm

Conductor connection interior

Connection method	Solder/Slip-on connection
-------------------	---------------------------

DFK/DP-2,8-FRONT 2,5 - Panel feed-through terminal block



0706524

<https://www.phoenixcontact.com/us/products/0706524>

Connection direction of the conductor to plug-in direction	0 °
Conductor cross-section rigid	0.2 mm ² ... 1.5 mm ²
Conductor cross-section flexible	0.2 mm ² ... 1.5 mm ²
Internal cylindrical gage	A3

Material specifications

Material data - contact

Note	WEEE/RoHS-compliant, free of whiskers according to IEC 60068-2-82/JEDEC JESD 201
Contact material	Cu alloy
Surface characteristics	tin-plated

Material data - housing

Color (Housing)	gray (7042)
Insulating material	PA
Insulating material group	I
CTI according to IEC 60112	600
Flammability rating according to UL 94	V2

Notes

Safety note

Safety note	<ul style="list-style-type: none">• Only electrically qualified personnel may install and operate the product. To recognize and prevent danger, the qualified personnel must be familiar with the basics of electrical engineering.• Observe the technical data provided here and refer to the documents listed under "Downloads". The download area contains important information, such as installation notes, technical drawings, and 3D data.• The cable entry funnel is not safe to touch. Never connect or disconnect the terminal when it is energized. Take appropriate steps to ensure touch protection.
-------------	---

Dimensions

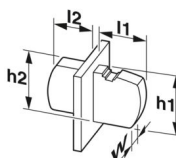
Dimensional drawing	
Pitch	6 mm
Width [w]	6.15 mm
Height [h]	26.6 mm
Length [l]	41.4 mm

Mechanical tests

DFK/DP-2,8-FRONT 2,5 - Panel feed-through terminal block



0706524

<https://www.phoenixcontact.com/us/products/0706524>

Test for conductor damage and slackening

Specification	IEC 60947-7-1:2009-04
Result	Test passed

Pull-out test

Specification	IEC 60947-7-1:2009-04
Conductor cross-section/conductor type/tractive force setpoint/actual value	0.2 mm ² / solid / > 10 N
	0.2 mm ² / flexible / > 10 N
	4 mm ² / solid / > 60 N
	2.5 mm ² / flexible / > 50 N

Electrical tests

Temperature-rise test

Specification	IEC 60947-7-1:2009-04
Requirement temperature-rise test	Increase in temperature ≤ 45 K

Short-time withstand current

Specification	IEC 60947-7-1:2009-04
---------------	-----------------------

Air clearances and creepage distances | 1. Insulation coordination

Specification	IEC 60947-7-1:2009-04
Insulating material group	I
Comparative tracking index (IEC 60112)	CTI 600
Rated insulation voltage (III/3)	400 V
Rated surge voltage (III/3)	4 kV
minimum clearance value - non-homogenous field (III/3)	3 mm
minimum creepage distance (III/3)	5 mm

Environmental and real-life conditions

Vibration test

Specification	IEC 60068-2-6:2007-12
Frequency	10 - 150 - 10 Hz
Sweep speed	1 octave/min
Amplitude	0.35 mm (10 Hz ... 60.1 Hz)
Acceleration	5g (60.1 Hz ... 150 Hz)
Test duration per axis	2.5 h
Test directions	X-, Y- and Z-axis

Glow-wire test

Specification	IEC 60695-2-11:2014-02
Temperature	960 °C
Time of exposure	30 s

Ambient conditions

Ambient temperature (storage/transport)	-40 °C ... 70 °C
---	------------------

DFK/DP-2,8-FRONT 2,5 - Panel feed-through terminal block



0706524

<https://www.phoenixcontact.com/us/products/0706524>

Relative humidity (storage/transport)	30 % ... 70 %
Ambient temperature (assembly)	-5 °C ... 100 °C
Ambient temperature (operation)	-40 °C ... 100 °C (Depending on the current carrying capacity/derating curve)

Ambient conditions

Ambient temperature (operation)	-40 °C ... 100 °C (Depending on the current carrying capacity/derating curve)
Ambient temperature (storage/transport)	-40 °C ... 70 °C
Relative humidity (storage/transport)	30 % ... 70 %
Ambient temperature (assembly)	-5 °C ... 100 °C

Packaging specifications

Type of packaging	packed in cardboard
-------------------	---------------------

DFK/DP-2,8-FRONT 2,5 - Panel feed-through terminal block

0706524

<https://www.phoenixcontact.com/us/products/0706524>

Drawings

Dimensional drawing

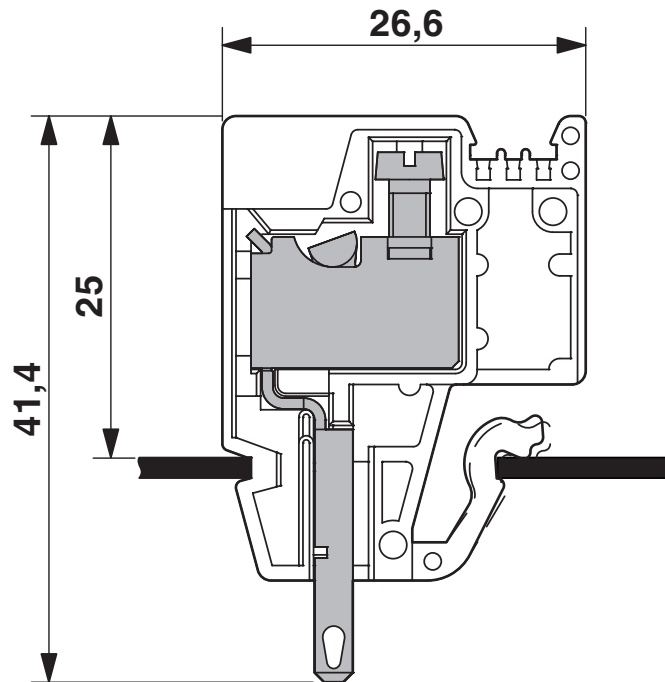

Diagram

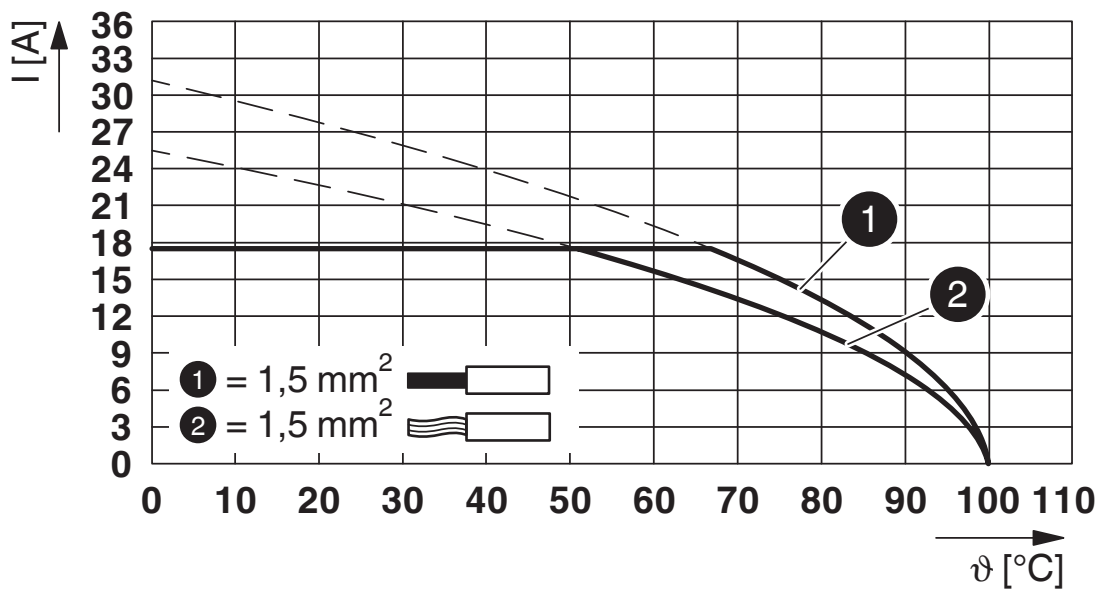

Type: DFK-2,8-FRONT 2,5

DFK/DP-2,8-FRONT 2,5 - Panel feed-through terminal block





0706524

<https://www.phoenixcontact.com/us/products/0706524>

Approvals

To download certificates, visit the product detail page: <https://www.phoenixcontact.com/us/products/0706524>

 CSA Approval ID: 13631				
	Nominal voltage U_N	Nominal current I_N	Cross section AWG	Cross section mm^2
keine				
	300 V	15 A	22 - 12	-

 cULus Recognized Approval ID: E60425-19900730				
	Nominal voltage U_N	Nominal current I_N	Cross section AWG	Cross section mm^2
keine				
	300 V	15 A	28 - 12	-

DFK/DP-2,8-FRONT 2,5 - Panel feed-through terminal block



0706524

<https://www.phoenixcontact.com/us/products/0706524>

Classifications

ECLASS

ECLASS-13.0	27141134
ECLASS-15.0	27141134

ETIM

ETIM 10.0	EC001283
-----------	----------

UNSPSC

UNSPSC 21.0	39121400
-------------	----------

DFK/DP-2,8-FRONT 2,5 - Panel feed-through terminal block



0706524

<https://www.phoenixcontact.com/us/products/0706524>

Environmental product compliance

EU RoHS

Fulfills EU RoHS substance requirements	Yes, No exemptions
---	--------------------

China RoHS

Environment friendly use period (EFUP)	EFUP-E
	No hazardous substances above the limits

EU REACH SVHC

REACH candidate substance (CAS No.)	No substance above 0.1 wt%
-------------------------------------	----------------------------

EF3.1 Climate Change

CO2e kg	0.13 kg CO2e
---------	--------------

Phoenix Contact 2026 © - all rights reserved
<https://www.phoenixcontact.com>

Phoenix Contact USA
586 Fulling Mill Road
Middletown, PA 17057, United States
(+717) 944-1300
info@phoenixcon.com