

UKH 240-3L/N/FE - High-current terminal block



3076471

<https://www.phoenixcontact.com/us/products/3076471>

Please be informed that the data shown in this PDF document is generated from our online catalog. Please find the complete data in the user documentation. Our general terms of use for downloads are valid.



High-current terminal block, nom. voltage: 1000 V, nominal current: 415 A, number of connections: 10, number of positions: 5, connection method: Screw connection, Rated cross section: 240 mm², cross section: 70 mm² - 240 mm², mounting type: NS 35/15, NS 32, color: gray/blue/black-yellow

Commercial data

Item number	3076471
Packing unit	1 pc
Note	Made to order (non-returnable)
Sales key	BE13
Product key	BE1311
GTIN	4046356654050
Weight per piece (including packing)	2,440.01 g
Weight per piece (excluding packing)	2,367.78 g
Customs tariff number	85369010
Country of origin	PL

UKH 240-3L/N/FE - High-current terminal block



3076471

<https://www.phoenixcontact.com/us/products/3076471>

Technical data

Product properties

Product type	High current terminal block
Number of positions	5
Number of connections	10
Number of rows	1
Potentials	5

Insulation characteristics

Overvoltage category	III
Degree of pollution	3

Electrical properties

Rated surge voltage	8 kV
---------------------	------

Connection data

Number of connections per level	10
Nominal cross section	240 mm ²

Level 1 above 1 below 1

Connection method	Screw connection
Screw thread	M10
Note	Screws with hexagonal socket
Tightening torque	25 ... 30 Nm
Stripping length	40 mm
Internal cylindrical gage	B15
Connection in acc. with standard	IEC 60947-7-1
Conductor cross-section rigid	70 mm ² ... 240 mm ²
Cross section AWG	2/0 ... 500 kcmil (converted acc. to IEC)
Conductor cross-section flexible	70 mm ² ... 240 mm ²
Conductor cross-section, flexible [AWG]	2/0 ... 500 kcmil (converted acc. to IEC)
Conductor cross-section flexible (ferrule without plastic sleeve)	70 mm ² ... 185 mm ²
Flexible conductor cross-section (ferrule with plastic sleeve)	70 mm ² ... 185 mm ²
Cross-section with insertion bridge, rigid	240 mm ²
Cross-section with insertion bridge, flexible	185 mm ²
2 conductors with same cross section, rigid	35 mm ² ... 95 mm ²
2 conductors with same cross section, flexible	50 mm ² ... 95 mm ²
2 conductors with same cross section, flexible, with ferrule without plastic sleeve	35 mm ² ... 50 mm ²
Nominal cross section	240 mm ²
Nominal current	415 A
Maximum load current	415 A (with 240 mm ² conductor cross-section)
Nominal voltage	1000 V
Note	Note: Product releases, connection cross sections and notes on

UKH 240-3L/N/FE - High-current terminal block



3076471

<https://www.phoenixcontact.com/us/products/3076471>

connecting aluminum cables can be found in the download area.

Dimensions

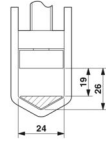
Dimensional drawing	
Width	180 mm
Height	123.6 mm

Material specifications

Color	gray/blue/black-yellow
Flammability rating according to UL 94	V0
Insulating material group	I
Insulating material	PA
Static insulating material application in cold	-60 °C
Temperature index of insulation material (DIN EN 60216-1 (VDE 0304-21))	130 °C
Relative insulation material temperature index (Elec., UL 746 B)	130 °C
Fire protection for rail vehicles (DIN EN 45545-2) R22	HL 1 - HL 3
Fire protection for rail vehicles (DIN EN 45545-2) R23	HL 1 - HL 3
Fire protection for rail vehicles (DIN EN 45545-2) R24	HL 1 - HL 3
Fire protection for rail vehicles (DIN EN 45545-2) R26	HL 1 - HL 3
Calorimetric heat release NFPA 130 (ASTM E 1354)	28 MJ/kg
Surface flammability NFPA 130 (ASTM E 162)	passed
Specific optical density of smoke NFPA 130 (ASTM E 662)	passed
Smoke gas toxicity NFPA 130 (SMP 800C)	passed

Electrical tests

Surge voltage test

Result	Test passed
Short-time withstand current 240 mm ²	28.8 kA
Result	Test passed

Power-frequency withstand voltage

Test voltage setpoint	2.2 kV
Result	Test passed

Mechanical properties

Mechanical data

Open side panel	No
-----------------	----

Mechanical tests

UKH 240-3L/N/FE - High-current terminal block



3076471

<https://www.phoenixcontact.com/us/products/3076471>

Mechanical strength

Result	Test passed
--------	-------------

Attachment on the carrier

DIN rail/fixing support	NS 32/NS 35
Result	Test passed

Environmental and real-life conditions

Needle-flame test

Time of exposure	30 s
Result	Test passed

Standards and regulations

Connection in acc. with standard	IEC 60947-7-1
----------------------------------	---------------

Mounting

Mounting type	NS 35/15
	NS 32

UKH 240-3L/N/FE - High-current terminal block

3076471

<https://www.phoenixcontact.com/us/products/3076471>

Drawings

Dimensional drawing

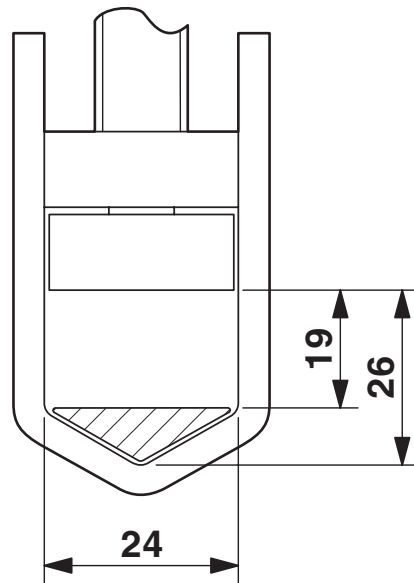

Schematic diagram

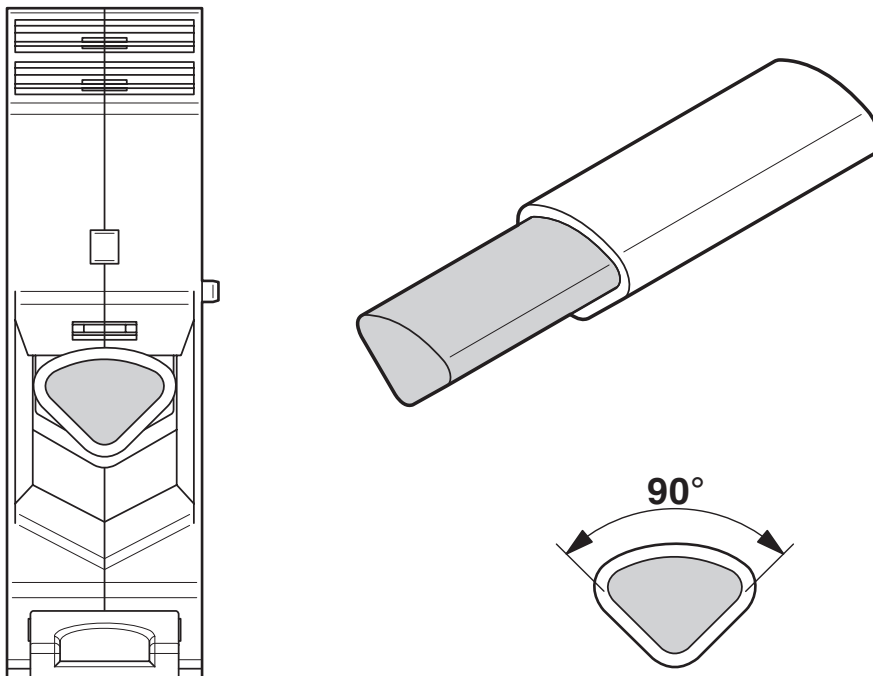

Connecting aluminum cables. Further notes can be found in the download area

UKH 240-3L/N/FE - High-current terminal block



3076471

<https://www.phoenixcontact.com/us/products/3076471>

Circuit diagram



Phoenix Contact 2026 © - all rights reserved
<https://www.phoenixcontact.com>

Phoenix Contact USA
586 Fulling Mill Road
Middletown, PA 17057, United States
(+717) 944-1300
info@phoenixcon.com