

# CGSA 50 - Cable guiding system



3071401

<https://www.phoenixcontact.com/us/products/3071401>

Please be informed that the data shown in this PDF document is generated from our online catalog. Please find the complete data in the user documentation. Our general terms of use for downloads are valid.

Cable guiding system, with swivel joint for opening, depth: 140.5 mm, width: 68 mm, height: 218 mm, diameter: 42 mm, color: gray



## Your advantages

- Subsequent wiring is easy, thanks to swivel joint openings that can be operated without tools
- Easily plan cable harnesses: the cable length is predefined through the swivel arm
- Integrated flanges with strain relief make assembly quick and easy
- Mechanical cable protection and bundling, thanks to protective covers that can be attached without tools
- Route preassembled cables and wires easily, thanks to the patent-pending swivel joint
- High-grade elastic and mechanically resilient plastic, certified according to UL 94 for flammability rating: V0
- Cable routing for the control cabinet door can be planned in the CAD system, thanks to the defined installation space and swivel range

## Commercial data

Item number	3071401
Packing unit	1 pc
Minimum order quantity	1 pc
Sales key	BE06
Product key	BE61ZX
GTIN	4055626289175
Weight per piece (including packing)	432.5 g
Weight per piece (excluding packing)	429.7 g
Customs tariff number	39259020
Country of origin	PL

# CGSA 50 - Cable guiding system

3071401

<https://www.phoenixcontact.com/us/products/3071401>

## Technical data

### Product properties

Product type	Cable feed-through
Number of cables	100 for 1.5 mm <sup>2</sup>

### Dimensions

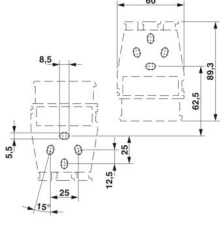
Dimensional drawing	
Width	68 mm
Height	218 mm
Depth	140.5 mm
Cable length	700 mm ... 460 mm
Drill hole distance, horizontal	25 mm
Drill hole distance, vertical	25 mm
Diameter	42 mm
Hole diameter	5.5 mm

### Material specifications

Color	gray (RAL 7042)
Material	PC
Flammability rating according to UL 94	V0
Static insulating material application in cold	-40 °C
Relative insulation material temperature index (Elec., UL 746 B)	130 °C
Fire protection for rail vehicles (DIN EN 45545-2) R22	HL 1 - HL 3
Fire protection for rail vehicles (DIN EN 45545-2) R23	HL 1 - HL 3
Fire protection for rail vehicles (DIN EN 45545-2) R24	HL 1 - HL 3
Components	halogen-free

### Environmental and real-life conditions

#### Needle-flame test

Time of exposure	30 s
Result	Test passed

#### Ambient conditions

Ambient temperature (operation)	-60 °C ... 85 °C (max. short-term operating temperature RTI Elec. )
Ambient temperature (storage/transport)	-25 °C ... 55 °C (for a short time, not exceeding 24 h, -60 °C to +70 °C)

# CGSA 50 - Cable guiding system



3071401

<https://www.phoenixcontact.com/us/products/3071401>

Ambient temperature (assembly)	-5 °C ... 70 °C
Ambient temperature (actuation)	-5 °C ... 70 °C
Permissible humidity (storage/transport)	30 % ... 70 %

# CGSA 50 - Cable guiding system

3071401

<https://www.phoenixcontact.com/us/products/3071401>

## Drawings

Dimensional drawing

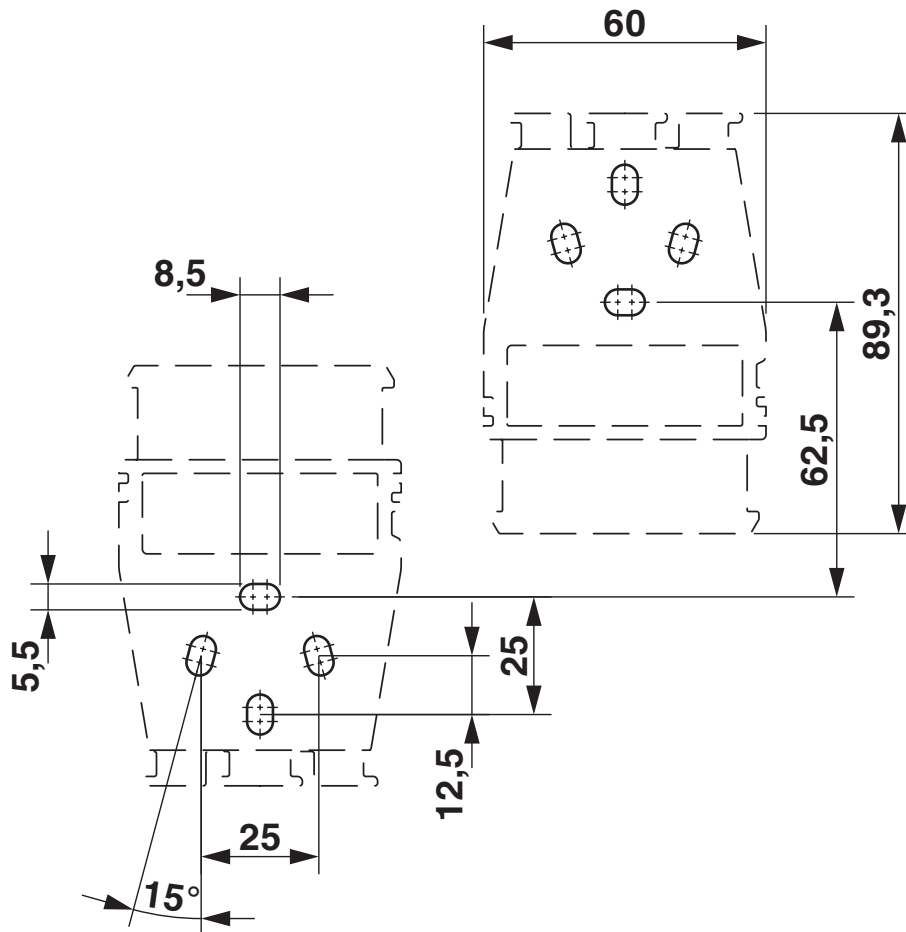

Dimensional drawing

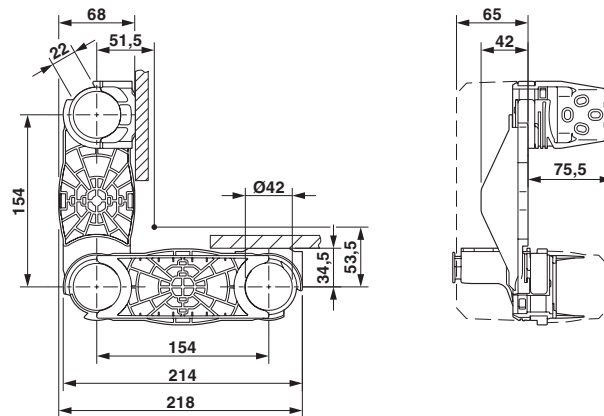

# CGSA 50 - Cable guiding system

3071401

<https://www.phoenixcontact.com/us/products/3071401>



Dimensional drawing

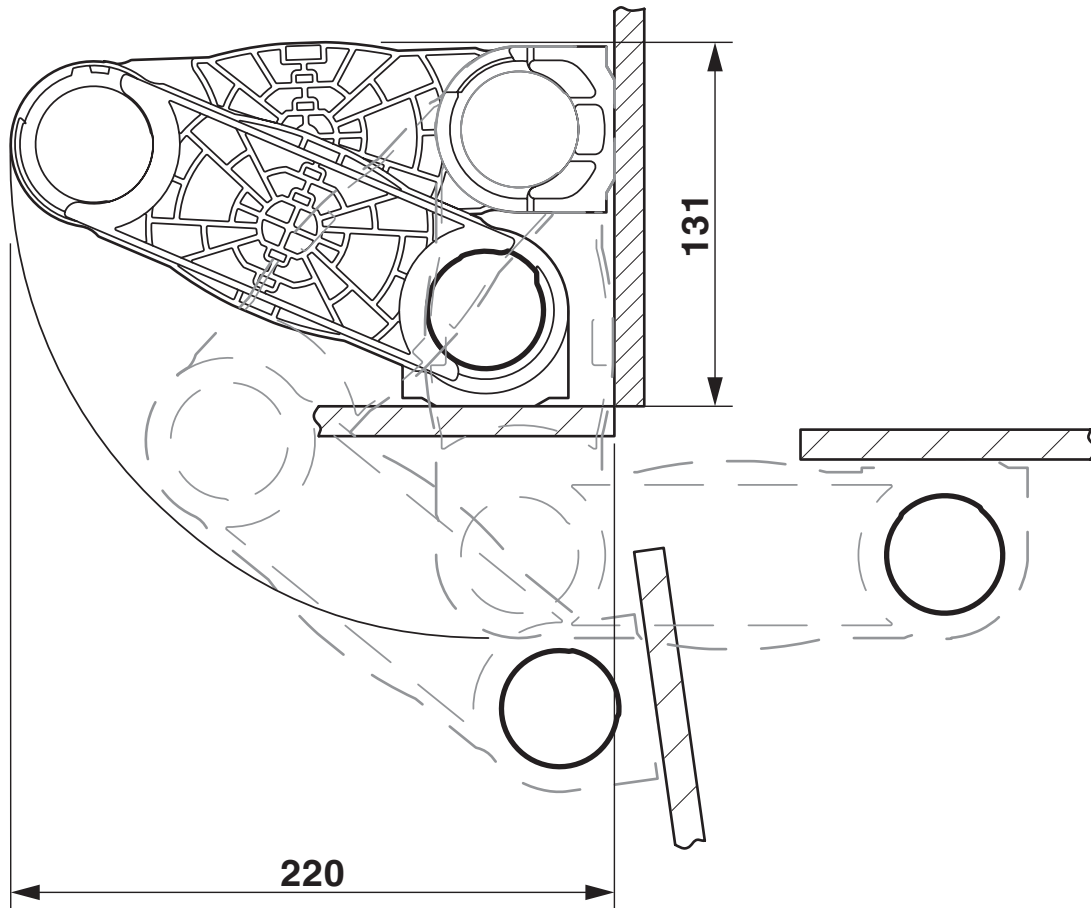

# CGSA 50 - Cable guiding system

3071401

<https://www.phoenixcontact.com/us/products/3071401>



Dimensional drawing

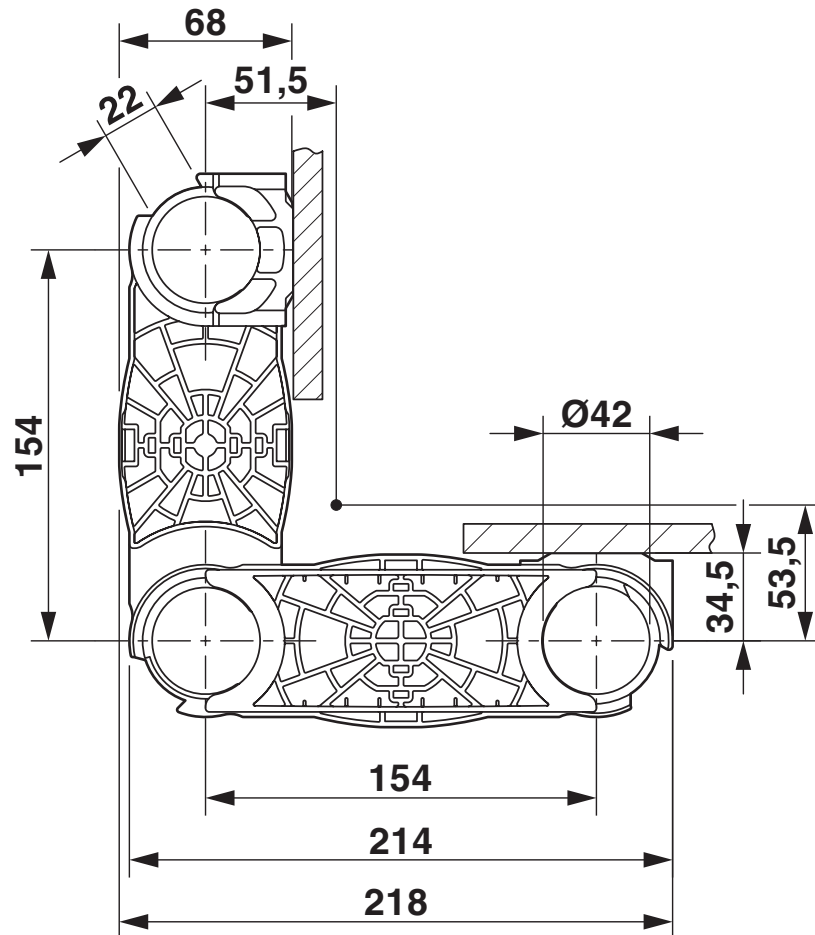

# CGSA 50 - Cable guiding system



3071401

<https://www.phoenixcontact.com/us/products/3071401>

## Approvals

🔗 To download certificates, visit the product detail page: <https://www.phoenixcontact.com/us/products/3071401>



**VDE Zeichengenehmigung**

Approval ID: 40047466

# CGSA 50 - Cable guiding system



3071401

<https://www.phoenixcontact.com/us/products/3071401>

## Classifications

### ECLASS

ECLASS-13.0	27182811
ECLASS-15.0	27182811

### ETIM

ETIM 10.0	EC002620
-----------	----------

### UNSPSC

UNSPSC 21.0	39121700
-------------	----------

# CGSA 50 - Cable guiding system



3071401

<https://www.phoenixcontact.com/us/products/3071401>

## Environmental product compliance

### EU RoHS

Fulfills EU RoHS substance requirements	Yes, No exemptions
---	--------------------

### China RoHS

Environment friendly use period (EFUP)	EFUP-E
	No hazardous substances above the limits

### EU REACH SVHC

REACH candidate substance (CAS No.)	No substance above 0.1 wt%
-------------------------------------	----------------------------

### EF3.1 Climate Change

CO2e kg	1.759 kg CO2e
---------	---------------

Phoenix Contact 2026 © - all rights reserved  
<https://www.phoenixcontact.com>

Phoenix Contact USA  
586 Fulling Mill Road  
Middletown, PA 17057, United States  
(+717) 944-1300  
[info@phoenixcon.com](mailto:info@phoenixcon.com)