

STME 6-BE - Component terminal block



3035688

<https://www.phoenixcontact.com/us/products/3035688>

Please be informed that the data shown in this PDF document is generated from our online catalog. Please find the complete data in the user documentation. Our general terms of use for downloads are valid.



Component terminal block, If several diode terminal blocks need adding to the DIN rail, a spacer plate must be placed between them., for installing components that can be individually selected, nom. voltage: 500 V, nominal current: 30 A, connection method: Spring-cage connection, Rated cross section: 6 mm², cross section: 0.2 mm² - 10 mm², color: gray

Commercial data

Item number	3035688
Packing unit	50 pc
Minimum order quantity	50 pc
Sales key	BE02
Product key	BE2171
GTIN	4046356743655
Weight per piece (including packing)	21.598 g
Weight per piece (excluding packing)	21.598 g
Customs tariff number	85369010
Country of origin	PL

STME 6-BE - Component terminal block



3035688

<https://www.phoenixcontact.com/us/products/3035688>

Technical data

Product properties

Product type	Component terminal block
Number of connections	2
Number of rows	1
Potentials	1

Electrical properties

Maximum power dissipation for nominal condition	1.31 W
---	--------

Connection data

Number of connections per level	2
Nominal cross section	6 mm ²
Connection method	Spring-cage connection
Stripping length	12 mm
Internal cylindrical gage	A4
Conductor cross-section rigid	0.2 mm ² ... 10 mm ²
Cross section AWG	24 ... 8 (converted acc. to IEC)
Conductor cross-section flexible	0.2 mm ² ... 6 mm ²
Conductor cross-section, flexible [AWG]	24 ... 10 (converted acc. to IEC)
Conductor cross-section flexible (ferrule without plastic sleeve)	0.25 mm ² ... 6 mm ²
Flexible conductor cross-section (ferrule with plastic sleeve)	0.25 mm ² ... 6 mm ²
2 conductors with the same cross section, flexible, with TWIN ferrule with plastic sleeve	0.5 mm ² ... 1.5 mm ²
Nominal cross section	6 mm ²
Nominal current	30 A (the current is determined by the component used)
Nominal voltage	500 V (the voltage is determined by the component used)

Dimensions

Width	8.2 mm
Height	100.8 mm
Depth on NS 35/7,5	60 mm
Depth on NS 35/15	67.5 mm

Material specifications

Color	gray (RAL 7042)
Flammability rating according to UL 94	V0
Insulating material	PA
Static insulating material application in cold	-60 °C
Temperature index of insulation material (DIN EN 60216-1 (VDE 0304-21))	130 °C
Relative insulation material temperature index (Elec., UL 746 B)	130 °C
Fire protection for rail vehicles (DIN EN 45545-2) R22	HL 1 - HL 3

STME 6-BE - Component terminal block



3035688

<https://www.phoenixcontact.com/us/products/3035688>

Fire protection for rail vehicles (DIN EN 45545-2) R23	HL 1 - HL 3
Fire protection for rail vehicles (DIN EN 45545-2) R24	HL 1 - HL 3
Fire protection for rail vehicles (DIN EN 45545-2) R26	HL 1 - HL 3
Calorimetric heat release NFPA 130 (ASTM E 1354)	28 MJ/kg
Surface flammability NFPA 130 (ASTM E 162)	passed
Specific optical density of smoke NFPA 130 (ASTM E 662)	passed
Smoke gas toxicity NFPA 130 (SMP 800C)	passed

Mechanical properties

Mechanical data

Open side panel	Yes
-----------------	-----

Environmental and real-life conditions

Ambient conditions

Ambient temperature (operation)	-60 °C ... 110 °C (Operating temperature range incl. self-heating; for max. short-term operating temperature, see RTI Elec.)
Ambient temperature (storage/transport)	-25 °C ... 60 °C (for a short time, not exceeding 24 h, -60 °C to +70 °C)
Ambient temperature (assembly)	-5 °C ... 70 °C
Ambient temperature (actuation)	-5 °C ... 70 °C
Permissible humidity (operation)	20 % ... 90 %
Permissible humidity (storage/transport)	30 % ... 70 %

Mounting

Mounting type	NS 35/7,5
	NS 35/15

STME 6-BE - Component terminal block

3035688

<https://www.phoenixcontact.com/us/products/3035688>

Drawings

Circuit diagram

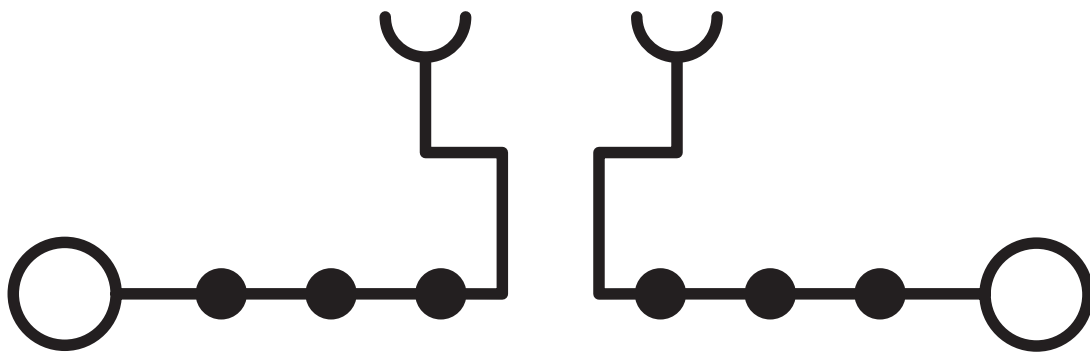

Circuit diagram



STME 6-BE - Component terminal block



3035688

<https://www.phoenixcontact.com/us/products/3035688>

Circuit diagram

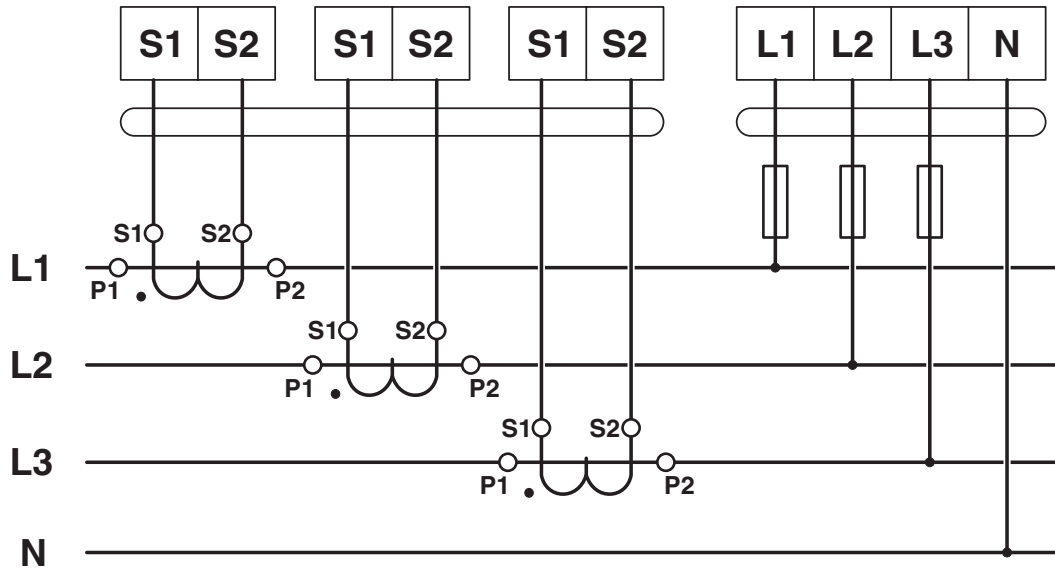

STME 6-BE - Component terminal block



3035688

<https://www.phoenixcontact.com/us/products/3035688>

Approvals

To download certificates, visit the product detail page: <https://www.phoenixcontact.com/us/products/3035688>



EAC

Approval ID: RU C-DE.BL08.B.00644



EAC

Approval ID: KZ7500651131219505

STME 6-BE - Component terminal block



3035688

<https://www.phoenixcontact.com/us/products/3035688>

Classifications

ECLASS

ECLASS-13.0	27250114
ECLASS-15.0	27250114

ETIM

ETIM 10.0	EC000898
-----------	----------

UNSPSC

UNSPSC 21.0	39121400
-------------	----------

STME 6-BE - Component terminal block



3035688

<https://www.phoenixcontact.com/us/products/3035688>

Environmental product compliance

EU RoHS

Fulfills EU RoHS substance requirements	Yes, No exemptions
---	--------------------

China RoHS

Environment friendly use period (EFUP)	EFUP-E
	No hazardous substances above the limits

EU REACH SVHC

REACH candidate substance (CAS No.)	No substance above 0.1 wt%
-------------------------------------	----------------------------

EF3.1 Climate Change

CO2e kg	0.12 kg CO2e
---------	--------------

Phoenix Contact 2026 © - all rights reserved
<https://www.phoenixcontact.com>

Phoenix Contact USA
586 Fulling Mill Road
Middletown, PA 17057, United States
(+717) 944-1300
info@phoenixcon.com