

PSR-SCP-24-230UC/ESAM4/3X1/1X2 - Safety relays



2981114

<https://www.phoenixcontact.com/us/products/2981114>

Please be informed that the data shown in this PDF document is generated from our online catalog. Please find the complete data in the user documentation. Our general terms of use for downloads are valid.



Safety relay for emergency stop and safety door monitoring up to SIL 3 or Cat. 4, PL e in accordance with EN ISO 13849, 1- or 2-channel operation, 3 enabling current paths, nominal input voltage: 24 V AC/DC ... 230 V AC/DC, plug-in screw terminal blocks

Your advantages

- With wide-range input (PSR-ESAM4/3X1)
- With inrush current reduction, therefore suitable for coupling to failsafe controllers (PSR-ESP4)
- 1- and 2-channel control

Commercial data

Item number	2981114
Packing unit	1 pc
Note	Made to order (non-returnable)
Sales key	DN01
Product key	DNA114
GTIN	4046356051644
Weight per piece (including packing)	416.4 g
Weight per piece (excluding packing)	305.48 g
Customs tariff number	85371098
Country of origin	DE

Technical data

Notes

Utilization restriction

EMC note	EMC: class A product, see manufacturer's declaration in the download area
----------	---

Product properties

Product type	Safety relays
Product family	PSRclassic
Application	Emergency stop
	Safety door
	Light grid
Control	1 and 2 channel
Mechanical service life	approx. 10^7 cycles
Relay type	Electromechanical relay with force-guided contacts in accordance with IEC/EN 61810-3

Insulation characteristics: Air clearances and creepage distances between the power circuits

Overvoltage category	III
Degree of pollution	2

Electrical properties

Maximum power dissipation for nominal condition	2.88 W
Nominal operating mode	100% operating factor

Air clearances and creepage distances between the power circuits

Rated insulation voltage	250 V AC
Rated surge voltage/insulation	6 kV/safe isolation, reinforced insulation and 6 kV between input circuits and output contact current paths (13/14, 23/24, 33/34), as well as between output contact current paths (13/14, 23/24, 33/34).

Input data

General

Input voltage range	24 V AC/DC ... 230 V AC/DC
Input voltage range in reference to U_N	0.85 ... 1.1
Typical input current at U_N	120 mA (at 24 V DC)
	20 mA (at 120 V AC)
	10 mA (at 230 V AC)
Voltage at input/start and feedback circuit	approx. 24 V DC
Typical response time	50 ms (manual start)
	60 ms (automatic start)
Typ. starting time with U_S	500 ms (when controlled via A1)
	20 ms (when controlled via S11/S12 and S21/S22)

PSR-SCP-24-230UC/ESAM4/3X1/1X2 - Safety relays



2981114

<https://www.phoenixcontact.com/us/products/2981114>

Typical release time	50 ms (at 24 V DC)
	110 ms (at 120 V AC)
	280 ms (at 230 V AC)
Concurrence	∞
Recovery time	1 s
Maximum switching frequency	0.5 Hz
Protective circuit	Surge protection; Suppressor diode and varistors
Max. permissible overall conductor resistance	11 Ω
Operating voltage display	1 x LED (green)
Status display	2 x LED (green)

Output data

Contact switching type	3 enabling current paths
	1 signaling current path
Contact material	AgSnO ₂ , + 0.2 μm Au
Maximum switching voltage	250 V AC/DC
Minimum switching voltage	10 V AC/DC
Limiting continuous current	6 A (N/O contact / N/C contact)
Maximum inrush current	6 A
Inrush current, minimum	10 mA
Sq. Total current	$50 \text{ A}^2 (I_{\text{TH}}^2 = I_1^2 + I_2^2 + \dots + I_N^2)$
Interrupting rating (ohmic load) max.	192 W (24 V DC, τ = 0 ms)
	384 W (48 V DC, τ = 0 ms)
	80 W (110 V DC, τ = 0 ms)
	66 W (220 V DC, τ = 0 ms)
	2000 VA (250 V AC, τ = 0 ms)
Maximum interrupting rating (inductive load)	48 W (24 V DC, τ = 40 ms)
	48 W (48 V DC, τ = 40 ms)
	48 W (110 V DC, τ = 40 ms)
	48 W (220 V DC, τ = 40 ms)
Switching power min.	360 mW
Switching capacity (360/h cycles)	4 A (24 V (DC13))
	4 A (230 V (AC15))
Switching capacity (3600/h cycles)	2.5 A (24 V (DC13))
	3 A (230 V (AC15))
Output fuse	6 A gG NEOZED
	B6/C4A gL/gG automatic device

Connection data

Connection technology	
pluggable	yes
Conductor connection	
Connection method	Screw connection

PSR-SCP-24-230UC/ESAM4/3X1/1X2 - Safety relays



2981114

<https://www.phoenixcontact.com/us/products/2981114>

Conductor cross-section, rigid	0.2 mm ² ... 2.5 mm ²
Conductor cross-section, flexible	0.2 mm ² ... 2.5 mm ²
Conductor cross-section AWG	24 ... 12
Stripping length	7 mm
Screw thread	M3

Dimensions

Width	45 mm
Height	99 mm
Depth	114.5 mm

Material specifications

Color	yellow
-------	--------

Characteristics

Safety data

Stop category (EN 60204-1)	0
----------------------------	---

Safety data: EN ISO 13849

Performance level (PL)	e
------------------------	---

Safety data: IEC 61508 - High demand

Safety Integrity Level (SIL)	3
------------------------------	---

Safety data: IEC 61508 - Low demand

Safety Integrity Level (SIL)	3
------------------------------	---

Safety data: EN IEC 62061

Safety Integrity Level (SIL)	3
------------------------------	---

Environmental and real-life conditions

Ambient conditions

Degree of protection	IP54 IP20
Min. degree of protection of inst. location	IP54
Ambient temperature (operation)	-20 °C ... 55 °C
Ambient temperature (storage/transport)	-25 °C ... 85 °C
Maximum altitude	≤ 2000 m (Above sea level)
Max. permissible humidity (storage/transport)	75 % (on average, 85% infrequently, non-condensing)
Max. permissible relative humidity (operation)	75 % (on average, 85% infrequently, non-condensing)
Shock	15g
Vibration (operation)	10 Hz ... 150 Hz, 2g

Standards and regulations

Air clearances and creepage distances between the power circuits

PSR-SCP-24-230UC/ESAM4/3X1/1X2 - Safety relays



2981114

<https://www.phoenixcontact.com/us/products/2981114>

Standards/regulations	DIN EN 50178/VDE 0160
-----------------------	-----------------------

Mounting

Mounting type	DIN rail mounting
Mounting position	any

Drawings

Circuit diagram

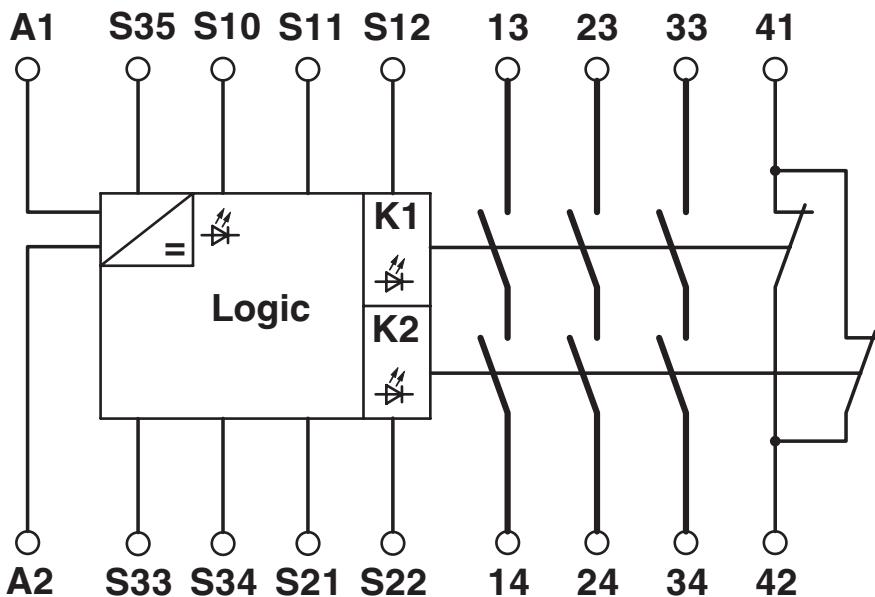

Block diagram

Circuit diagram

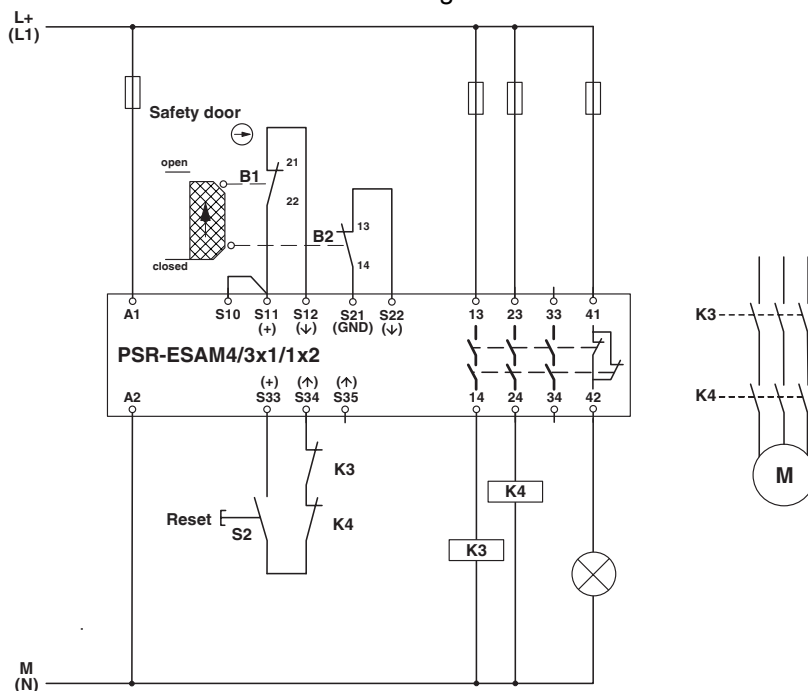

Two-channel safety door monitoring

2981114

<https://www.phoenixcontact.com/us/products/2981114>

Environmental product compliance

China RoHS

Environment friendly use period (EFUP)	EFUP-50
	An article-related China RoHS declaration table can be found in the download area for the respective article under "Manufacturer declaration". For all articles with EFUP-E, no China RoHS declaration table issued and required.

EU REACH SVHC

REACH candidate substance (CAS No.)	No substance above 0.1 wt%
-------------------------------------	----------------------------

Phoenix Contact 2026 © - all rights reserved
<https://www.phoenixcontact.com>

Phoenix Contact USA
586 Fulling Mill Road
Middletown, PA 17057, United States
(+717) 944-1300
info@phoenixcon.com