

# ELR W1/10-24DC - Reversing load relay

2964306

<https://www.phoenixcontact.com/us/products/2964306>

Please be informed that the data shown in this PDF document is generated from our online catalog. Please find the complete data in the user documentation. Our general terms of use for downloads are valid.



Electronic reversing load relay, for driving DC motors, with light indicator and protection circuit, output: 10 ... 30 V DC/10 A

## Commercial data

Item number	2964306
Packing unit	1 pc
Note	Made to order (non-returnable)
Sales key	C476
Product key	DK7623
GTIN	4017918187637
Weight per piece (including packing)	717 g
Weight per piece (excluding packing)	607.82 g
Customs tariff number	85371098
Country of origin	DE

# ELR W1/10-24DC - Reversing load relay



2964306

<https://www.phoenixcontact.com/us/products/2964306>

## Technical data

### Product properties

Product type	Solid-state contactor
--------------	-----------------------

### Insulation characteristics

Overvoltage category	III
----------------------	-----

### Electrical properties

Number of phases	1
Maximum power dissipation for nominal condition	0.36 W
Mains type	1-phase
Test voltage (Input/output)	2.5 kV AC (50 Hz, 60 s)

### Supply

Input name	Device supply
Nominal supply voltage	24 V DC $\pm$ 20 %
Input voltage range	19.2 V DC ... 28.8 V DC
Current consumption	max. 10 mA
Rated control circuit supply voltage $U_S$	24 V DC
Control supply voltage range	19.2 V DC ... 28.8 V DC
Protective circuit	Reverse polarity protection; Polarity protection diode
Status display	LED (green)

### Input data

#### Control

Input name	Control input right/left
Nominal input voltage $U_N$	24 V DC
Input voltage range in reference to $U_N$	0.8 ... 1.2
Input voltage range	19.2 V DC ... 28.8 V DC
Input voltage range in reference to $U_N$	0.8 ... 1.2
Current consumption	approx. 3 mA

### Output data

#### DC output

Operating voltage range	10 V DC ... 30 V DC
Nominal output voltage range	10 V DC ... 30 V DC
Continuous load current	10 A
Protective circuit	Reverse polarity protection
	Overload protection
	Surge protection
	Overcurrent protection
Current limitation at short-circuits	20 A

# ELR W1/10-24DC - Reversing load relay



2964306

<https://www.phoenixcontact.com/us/products/2964306>

## Connection data

### Control circuits

Connection method	Screw connection
Stripping length	8 mm
Screw thread	M3
Conductor cross-section rigid	0.2 mm <sup>2</sup> ... 6 mm <sup>2</sup>
Conductor cross-section flexible	0.2 mm <sup>2</sup> ... 4 mm <sup>2</sup>
Conductor cross-section AWG	24 ... 10

### Load circuit

Connection method	Screw connection
Stripping length	8 mm
Screw thread	M3
Conductor cross-section rigid	0.2 mm <sup>2</sup> ... 6 mm <sup>2</sup>
Conductor cross-section flexible	0.2 mm <sup>2</sup> ... 4 mm <sup>2</sup>
Conductor cross-section AWG	24 ... 10

## Dimensions

Width	62 mm
Height	84 mm
Depth	110 mm

## Material specifications

Color	green (RAL 6021)
-------	------------------

## Environmental and real-life conditions

### Ambient conditions

Degree of protection	IP20
Ambient temperature (operation)	-20 °C ... 60 °C
Ambient temperature (storage/transport)	-20 °C ... 70 °C

## Standards and regulations

Standards/regulations	EN 50178
-----------------------	----------

## Mounting

Mounting type	DIN rail mounting
Assembly note	can be aligned with spacing = 20 mm
Mounting position	Vertical (horizontal DIN rail)

# ELR W1/10-24DC - Reversing load relay

2964306

<https://www.phoenixcontact.com/us/products/2964306>

## Drawings

Circuit diagram

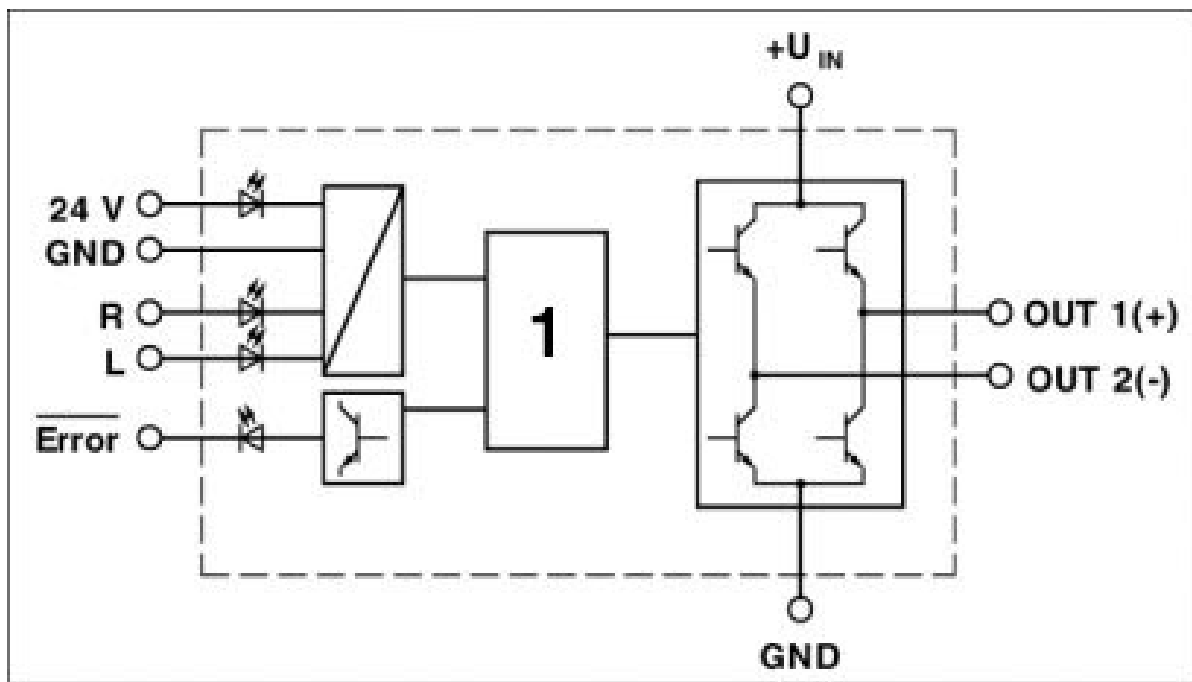

1 = logics

# ELR W1/10-24DC - Reversing load relay



2964306

<https://www.phoenixcontact.com/us/products/2964306>

## Classifications

### UNSPSC

UNSPSC 21.0	39122333
-------------	----------

# ELR W1/10-24DC - Reversing load relay



2964306

<https://www.phoenixcontact.com/us/products/2964306>

## Environmental product compliance

### EU RoHS

Fulfills EU RoHS substance requirements	Yes
Exemption	7(a), 7(c)-I

### China RoHS

Environment friendly use period (EFUP)	EFUP-50
	An article-related China RoHS declaration table can be found in the download area for the respective article under "Manufacturer declaration". For all articles with EFUP-E, no China RoHS declaration table issued and required.

### EU REACH SVHC

REACH candidate substance (CAS No.)	Lead(CAS: 7439-92-1)
-------------------------------------	----------------------

Phoenix Contact 2026 © - all rights reserved  
<https://www.phoenixcontact.com>

Phoenix Contact USA  
586 Fulling Mill Road  
Middletown, PA 17057, United States  
(+717) 944-1300  
[info@phoenixcon.com](mailto:info@phoenixcon.com)