

# MACX MCR-SL-TC-I-NC - Temperature measuring transducer



2924346

<https://www.phoenixcontact.com/us/products/2924346>

Please be informed that the data shown in this PDF document is generated from our online catalog. Please find the complete data in the user documentation. Our general terms of use for downloads are valid.



Temperature transducer, converts signals from thermocouples and linear mV sources into 0/4 - 20 mA analog signals. Freely programmable, 3-way electrical isolation, custom-configured. Replacement item: 1050228 MACX MCR-TC-I.

## Your advantages

- Input for thermocouples and mV sources
- Power supply possible via DIN rail connector
- Installation in zone 2, protection type "n" (EN 60079-15) permitted
- Output: 0 mA ... 20 mA or 4 mA ... 20 mA
- Programming during operation and also voltage-free using IFS-USB-PROG-ADAPTER programming adapter
- Status indicator for supply voltage, cable, sensor, and module errors
- 3-way electrical isolation
- Configuration via software (FDT/DTM): sensor type, connection technology, measuring range, measuring unit, filter, alarm signal, and output range

## Commercial data

Item number	2924346
Packing unit	1 pc
Note	Made to order (non-returnable)
Sales key	C402
Product key	DK1115
GTIN	4046356515443
Weight per piece (including packing)	163 g
Weight per piece (excluding packing)	122.4 g
Customs tariff number	85437090
Country of origin	DE

# MACX MCR-SL-TC-I-NC - Temperature measuring transducer



2924346

<https://www.phoenixcontact.com/us/products/2924346>

## Technical data

### Product properties

Product type	Temperature transmitter
Application	Temperature
No. of channels	1

### Insulation characteristics

Overvoltage category	II
Pollution degree	2

### Electrical properties

Alignment span	$\pm 5\%$
Alignment zero	$\pm 5\%$
Electrical isolation	3-way isolation
Typical cold point errors	$\pm 1\text{ K}$
Step response (0–99%)	$\leq 1100\text{ ms}$ (when oversampling = 10 and moving average value = 1)
Temperature coefficient, typical	0.01 %/K

### Electrical isolation Input/output/power supply

Rated insulation voltage	300 V <sub>rms</sub>
Test voltage	2.5 kV AC (50 Hz, 60 s)
Insulation	Safe isolation in accordance with IEC/EN 61010-1

### Electrical isolation Input/output

Electrical isolation	375 V (Peak value in accordance with IEC/EN 60079-11)
----------------------	-------------------------------------------------------

### Electrical isolation Input/power supply

Electrical isolation	375 V (Peak value in accordance with IEC/EN 60079-11)
----------------------	-------------------------------------------------------

### Supply

Nominal supply voltage	24 V DC
Supply voltage range	19.2 V DC ... 30 V DC (24 V DC, -20 % ... +25 %)
Max. current consumption	< 40 mA (24 V DC)
Power dissipation	< 1 W

## Input data

### Signal

Number of inputs	1
Input signal	Temperature Voltage
Voltage input signal	-20 mV ... 70 mV

### Measurement

Sensor types that can be used (TC)	E, J, K, N as per IEC / EN 60584, L as per DIN 43760
------------------------------------	------------------------------------------------------

# MACX MCR-SL-TC-I-NC - Temperature measuring transducer



2924346

<https://www.phoenixcontact.com/us/products/2924346>

Temperature measuring range	-250 °C ... 1372 °C (Range depending on the sensor type)
Temperature measuring range: Type J thermocouple	-210 °C ... 1200 °C
Temperature measuring range: Type K thermocouple	-200 °C ... 1372 °C
Temperature measuring range: Type N thermocouple	-200 °C ... 1300 °C
Temperature measuring range: Type E thermocouple	-226 °C ... 1000 °C
Temperature measuring range: Type L thermocouple	-200 °C ... 900 °C
Linear mV signal range	-20 mV ... 70 mV
Temperature measuring range	Min. 50 K for thermocouples, 3 mV for mV sources

## Output data

Switching:

Configurable/programmable	no
---------------------------	----

Signal

Output description	Current output
Number of outputs	1
Configurable/programmable	Yes
Current output signal	0 mA ... 20 mA 4 mA ... 20 mA
Load/output load current output	max. 500 Ω
Output ripple (current)	< 50 μA <sub>pp</sub> < 10 μA <sub>rms</sub>
Behavior in the event of a sensor error	As per NE 43 or can be freely defined

## Connection data

Connection method	Screw connection
Stripping length	7 mm
Screw thread	M3
Conductor cross-section rigid	0.2 mm <sup>2</sup> ... 2.5 mm <sup>2</sup>
Conductor cross-section flexible	0.2 mm <sup>2</sup> ... 2.5 mm <sup>2</sup>
Conductor cross-section AWG	24 ... 14
Tightening torque	0.5 Nm ... 0.6 Nm

## Signaling

Status display	LED supply voltage, PWR (green)
	Red LED, flashing 2.8 Hz (cable error, sensor error on input or output, ERR)
	Red LED, flashing 1.2 Hz (simulation mode, ERR)
	Red LED, permanently on (module error, ERR)

## Dimensions

# MACX MCR-SL-TC-I-NC - Temperature measuring transducer



2924346

<https://www.phoenixcontact.com/us/products/2924346>

Dimensional drawing	
Width	12.5 mm
Height	106.4 mm
Depth	114.5 mm

## Material specifications

Color	gray (RAL 7042)
Flammability rating according to UL 94 (Housing)	V0 (Housing)
Housing material	PA 6.6-FR

## Environmental and real-life conditions

### Ambient conditions

Degree of protection	IP20 (not assessed by UL)
Ambient temperature (operation)	-20 °C ... 60 °C (Any mounting position)
Ambient temperature (storage/transport)	-40 °C ... 80 °C
Altitude	≤ 2000 m
Permissible humidity (operation)	5 % ... 95 % (non-condensing)

## Approvals

### CE

Certificate	CE-compliant
Note	and EN 61326-1

### ATEX

Identification	⊕ II 3G Ex nA ic IIC T4 Gc X
----------------	------------------------------

### UL, USA/Canada

Identification	UL 508 Listed
	UL 61010 Listed
	Class I, Div. 2, Groups A, B, C, D T4
	Class I, Zone 2, Group IIC T4

### Shipbuilding approval

Certificate	GL 86 644-10HH
-------------	----------------

### GL

Identification	C, EMC1
----------------	---------

## EMC data

Electromagnetic compatibility	Conformance with EMC directive
-------------------------------	--------------------------------

# MACX MCR-SL-TC-I-NC - Temperature measuring transducer



2924346

<https://www.phoenixcontact.com/us/products/2924346>

Noise immunity	EN 61000-6-2
Note	When being exposed to interference, there may be minimal deviations.

## Noise emission

Standards/regulations	EN 61000-6-4
-----------------------	--------------

## Electromagnetic HF field

Designation	Electromagnetic RF field
Standards/regulations	EN 61000-4-3

## Fast transients (burst)

Designation	Fast transients (burst)
Standards/regulations	EN 61000-4-4

## Conducted interference

Designation	Conducted interferences
Standards/regulations	EN 61000-4-6

## Standards and regulations

Electrical isolation	3-way isolation
----------------------	-----------------

## Mounting

Mounting type	DIN rail mounting
---------------	-------------------

# MACX MCR-SL-TC-I-NC - Temperature measuring transducer

2924346

<https://www.phoenixcontact.com/us/products/2924346>

## Drawings

Dimensional drawing

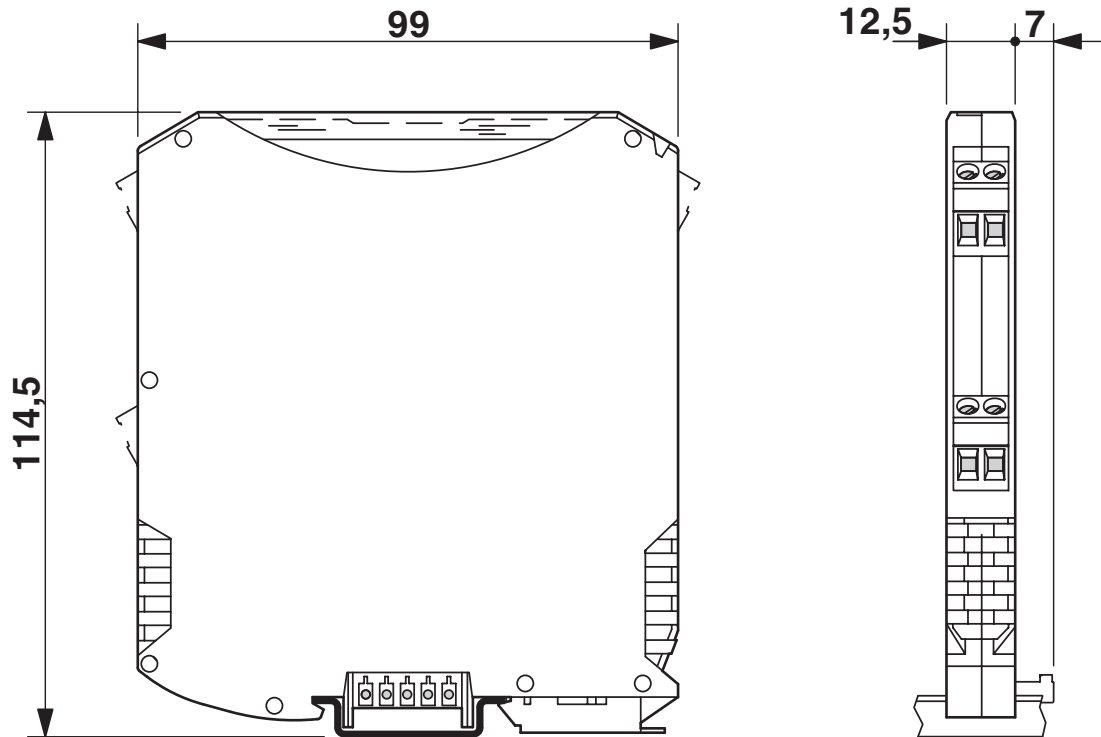

# MACX MCR-SL-TC-I-NC - Temperature measuring transducer



2924346

<https://www.phoenixcontact.com/us/products/2924346>

Block diagram

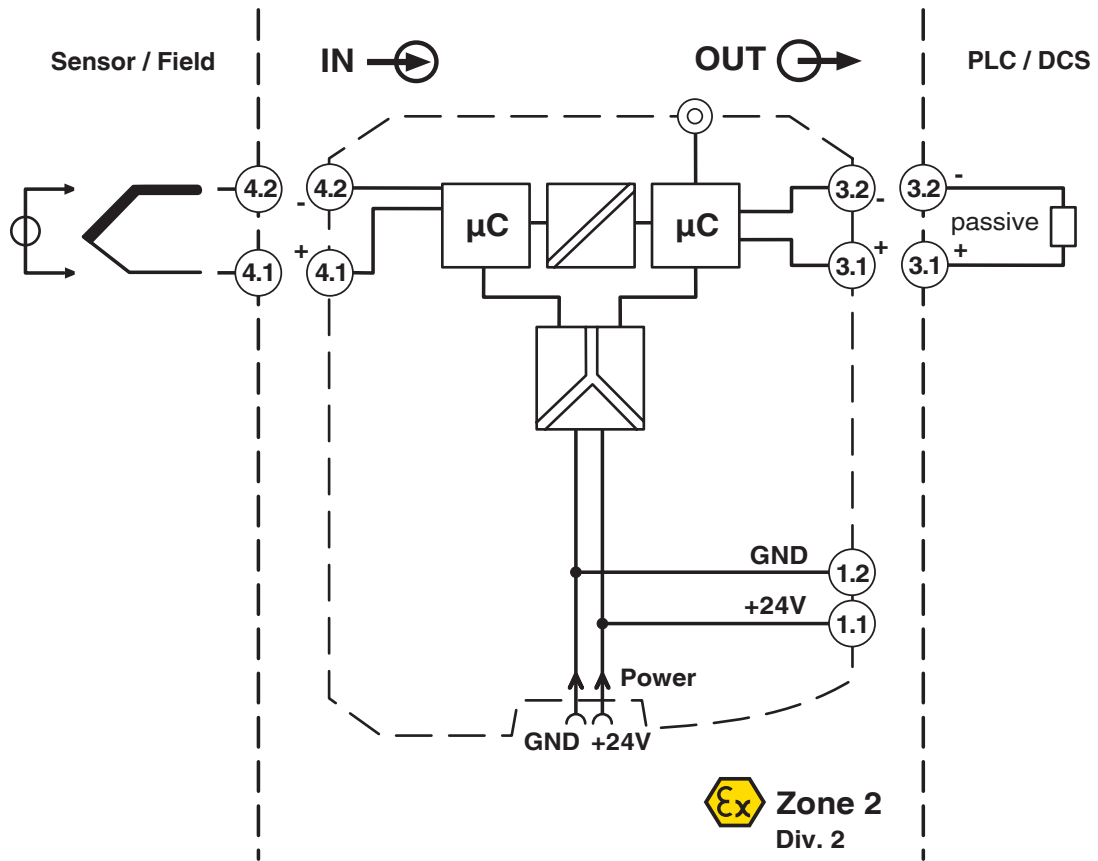

# MACX MCR-SL-TC-I-NC - Temperature measuring transducer



2924346

<https://www.phoenixcontact.com/us/products/2924346>

## Classifications

### ECLASS

ECLASS-13.0	27210129
-------------	----------

### UNSPSC

UNSPSC 21.0	41112105
-------------	----------

# MACX MCR-SL-TC-I-NC - Temperature measuring transducer



2924346

<https://www.phoenixcontact.com/us/products/2924346>

## Environmental product compliance

### EU RoHS

Fulfills EU RoHS substance requirements	Yes
Exemption	7(a), 7(c)-I

### China RoHS

Environment friendly use period (EFUP)	EFUP-50
	An article-related China RoHS declaration table can be found in the download area for the respective article under "Manufacturer declaration". For all articles with EFUP-E, no China RoHS declaration table issued and required.

### EU REACH SVHC

REACH candidate substance (CAS No.)	No substance above 0.1 wt%
-------------------------------------	----------------------------

Phoenix Contact 2026 © - all rights reserved  
<https://www.phoenixcontact.com>

Phoenix Contact USA  
586 Fulling Mill Road  
Middletown, PA 17057, United States  
(+717) 944-1300  
[info@phoenixcon.com](mailto:info@phoenixcon.com)