

TTC-6-2-HC-24DC-UT-I - Surge protection device



2908438

<https://www.phoenixcontact.com/us/products/2908438>

Please be informed that the data shown in this PDF document is generated from our online catalog. Please find the complete data in the user documentation. Our general terms of use for downloads are valid.



Surge protection with integrated status indicator for a 2-wire floating signal circuit with high nominal current, KNX-compatible. Can be used in safety-related circuits up to SIL 3.

Your advantages

- Space-saving and cost-saving with a narrow overall width of just 6 mm
- Continuous monitoring of protective devices, plus mechanical status indicator with optional remote signaling
- Finding the right product for all possible requirements in MCR applications is easy, thanks to the complete range of products with customized features

Commercial data

Item number	2908438
Packing unit	1 pc
Minimum order quantity	1 pc
Sales key	CL23
Product key	CL2261
GTIN	4055626300429
Weight per piece (including packing)	40 g
Weight per piece (excluding packing)	33.71 g
Customs tariff number	85363010
Country of origin	DE

TTC-6-2-HC-24DC-UT-I - Surge protection device



2908438

<https://www.phoenixcontact.com/us/products/2908438>

Technical data

Product properties

Product type	Surge protection for MCR technology
Product family	TERMITRAB complete
IEC test classification	C1
	C2
	C3
	D1
Type	DIN rail module, one-piece

Insulation characteristics

Overvoltage category	III
Pollution degree	2

Electrical properties

Nominal voltage U_N	24 V DC
-----------------------	---------

Connection data

Connection method	Screw connection
Screw thread	M3
Tightening torque	0.5 Nm ... 0.6 Nm
Conductor cross-section flexible	0.2 mm ² ... 2.5 mm ²
Conductor cross-section rigid	0.2 mm ² ... 4 mm ²
Conductor cross-section AWG	24 ... 12

Dimensions

Dimensional drawing	
Width	6.2 mm +0.1 mm
Height	105.8 mm
Depth	83.5 mm (incl. DIN rail 7.5 mm)

Material specifications

Color	gray (RAL 7042)
Flammability rating according to UL 94	V-0
Insulating material	PBT
Housing material	PBT

Mechanical properties

TTC-6-2-HC-24DC-UT-I - Surge protection device



2908438

<https://www.phoenixcontact.com/us/products/2908438>

Mechanical data

Open side panel	No
-----------------	----

Protective circuit

Direction of action	Line-Line & Line-Signal Ground/Shield & optional Signal Ground/Shield-Earth Ground
Nominal voltage U_N	24 V DC
Maximum continuous operating voltage U_C	30 V DC
	21 V AC
Rated current	6 A (55 °C)
Operating effective current I_C at U_C	$\leq 5 \mu A$
Protective conductor current I_{PE}	$\leq 1 \mu A$
Nominal discharge current I_n (8/20) μs (line-line)	0.5 kA
Nominal discharge current I_n (8/20) μs (line-ground)	5 kA
Pulse discharge current I_{imp} (10/350) μs (line-earth)	0.5 kA
Total discharge current I_{Total} (8/20) μs	5 kA
Voltage protection level U_p (line-line)	≤ 50 V (C1 - 1 kV / 500 A)
	≤ 45 V (C3 - 25 A)
	≤ 50 V (C3 - 100 A)
Voltage protection level U_p (line-earth)	≤ 1.35 kV (C1 - 1 kV / 500 A)
	≤ 1.45 kV (C2 - 10 kV / 5 kA)
	≤ 850 V (C3 - 25 A)
	≤ 1.1 kV (C3 - 100 A)
Response time t_A (line-line)	≤ 1 ns
Response time t_A (line-earth)	≤ 100 ns
Input attenuation aE, sym.	typ. 0.3 dB (≤ 300 kHz / 150 Ω)
Cut-off frequency f_g (3 dB), sym. in 150 Ω system	typ. 1 MHz
Capacity (Core-Earth)	typ. 2.2 nF
Resistance per path	≤ 100 m Ω
Surge protection fault message	optical
Max. required back-up fuse	6.3 A (FF)
Impulse durability (line-line)	C1 - 1 kV / 500 A
	C3 - 100 A
Impulse durability (line-earth)	C1 - 1 kV / 500 A
	C2 - 10 kV / 5 kA
	C3 - 100 A
	D1 - 500 A
Pulse reset time (line-earth)	≤ 40 ms

Environmental and real-life conditions

Ambient conditions

Degree of protection	IP20
Ambient temperature (operation)	-40 °C ... 85 °C

TTC-6-2-HC-24DC-UT-I - Surge protection device



2908438

<https://www.phoenixcontact.com/us/products/2908438>

Ambient temperature (storage/transport)	-40 °C ... 85 °C
Altitude	≤ 4000 m (amsl)
Permissible humidity (operation)	5 % ... 95 %

Standards and regulations

Standards/specifications	IEC 61643-21
Note	2000 + corrigendum 2001 + A1:2008, modified + A2:2012

EN 61643-21

Standards/specifications	EN 61643-21
Note	2001 + A1:2009 + A2:2013

Mounting

Mounting type	DIN rail: TH 35 - 7.5 mm
---------------	--------------------------

TTC-6-2-HC-24DC-UT-I - Surge protection device



2908438

<https://www.phoenixcontact.com/us/products/2908438>

Drawings

Dimensional drawing

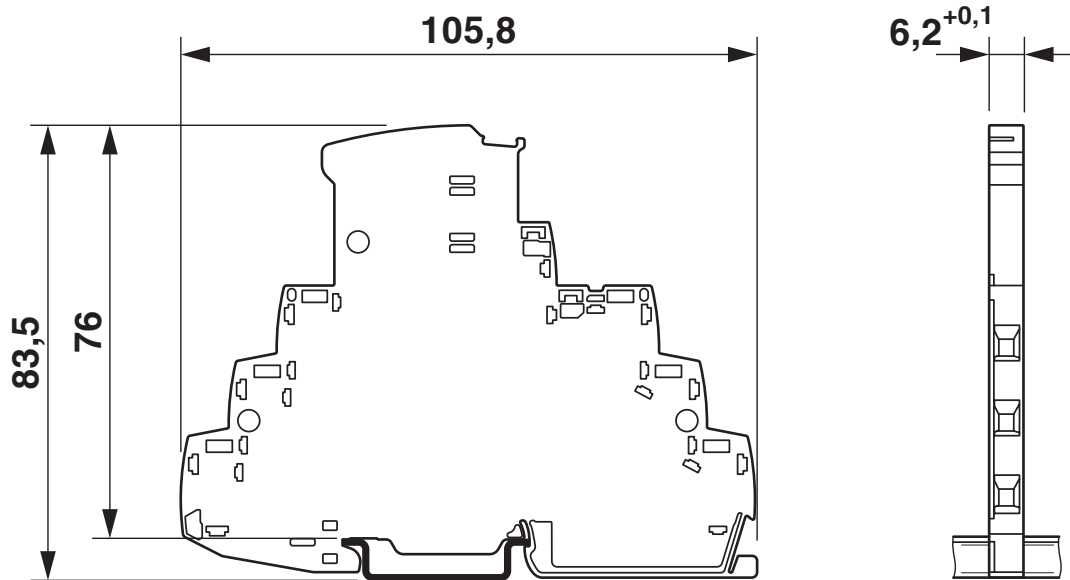

Schematic diagram

TTC-6-2-HC-...-I									
Category	1oo1 architecture, HFT=0				1oo2 architecture, HFT=1				
	PFD _{AVG}	PFH	Used budget of SIL 2 SIF		PFD _{AVG}	PFH	CCF	Used budget of SIL 3 SIF	
			PFD _{AVG}	PFH				PFD _{AVG}	PFH
	4.50·10 ⁻⁶	8.00·10 ⁻¹⁰ 1/h	0.0 %	0.1 %	2.25·10 ⁻⁷	4.00·10 ⁻¹¹ 1/h	5 %	0.0 %	0.0 %
					4.50·10 ⁻⁷	8.00·10 ⁻¹¹ 1/h	10 %	0.0 %	0.1 %
Calculation based on exida report, Phoenix Contact 16/06-072 R023 V3R1 exida Profile 1, FMEDA Analysis 2, T _{proof} : 1 year, MT: 10 years, MTTR: 24 hours, PTC: 99% Used standards IEC/EN 61508, edition 2010 (device specific) IEC/EN 61511, edition 2016 + COR1:2016 + A1:2017 (system specific)									

Functional safety scenarios

TTC-6-2-HC-24DC-UT-I - Surge protection device



2908438

<https://www.phoenixcontact.com/us/products/2908438>

Diagram



Circuit diagram

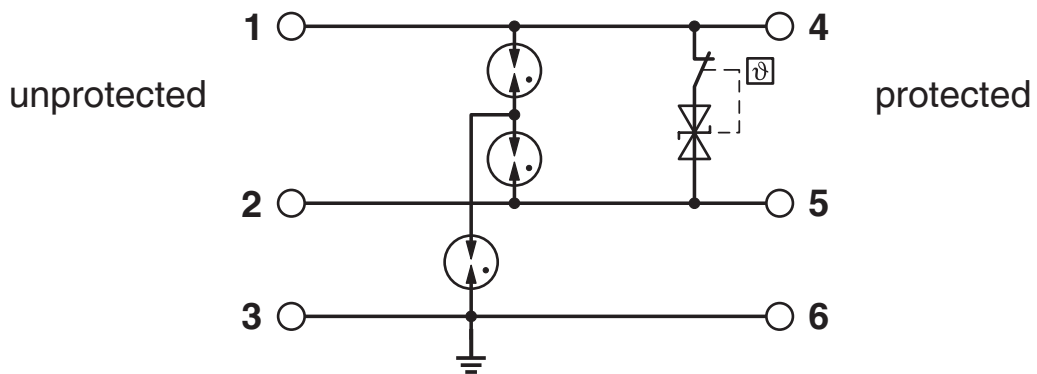

TTC-6-2-HC-24DC-UT-I - Surge protection device



2908438

<https://www.phoenixcontact.com/us/products/2908438>

Approvals

To download certificates, visit the product detail page: <https://www.phoenixcontact.com/us/products/2908438>



CSA

Approval ID: 70136717



DNV GL

Approval ID: TAE000027G



UL Listed

Approval ID: FILE E 138168



CSAus

Approval ID: 70136717

UAE-RoHS

Approval ID: 22-06-16191

Functional Safety

Approval ID: 16-06-072 R023 V3R1

TTC-6-2-HC-24DC-UT-I - Surge protection device



2908438

<https://www.phoenixcontact.com/us/products/2908438>

Classifications

ECLASS

ECLASS-13.0	27171501
ECLASS-15.0	27171501

ETIM

ETIM 10.0	EC001466
-----------	----------

UNSPSC

UNSPSC 21.0	39121600
-------------	----------

TTC-6-2-HC-24DC-UT-I - Surge protection device



2908438

<https://www.phoenixcontact.com/us/products/2908438>

Environmental product compliance

EU RoHS

Fulfills EU RoHS substance requirements	Yes
Exemption	7(a)

China RoHS

Environment friendly use period (EFUP)	EFUP-50
	An article-related China RoHS declaration table can be found in the download area for the respective article under "Manufacturer declaration". For all articles with EFUP-E, no China RoHS declaration table issued and required.

EU REACH SVHC

REACH candidate substance (CAS No.)	Lead(CAS: 7439-92-1)
SCIP	e6620c67-3aad-4ea0-a08b-9a5836d9f999

EF3.1 Climate Change

CO2e kg	1.633 kg CO2e
---------	---------------

Phoenix Contact 2026 © - all rights reserved
<https://www.phoenixcontact.com>

Phoenix Contact USA
586 Fulling Mill Road
Middletown, PA 17057, United States
(+717) 944-1300
info@phoenixcon.com