

PSR-SPP-24DC/MXF4/4X1/2X2/B - Safety relays



2903261

<https://www.phoenixcontact.com/us/products/2903261>

Please be informed that the data shown in this PDF document is generated from our online catalog. Please find the complete data in the user documentation. Our general terms of use for downloads are valid.



Multifunctional safety relay for emergency stop, safety doors, and light grid up to SIL 3, Cat. 4, PL e, automatically or manually monitored activation, 4 N/O contacts, 3 safety functions, 2 shutdown levels, plug-in spring-cage terminal block

Your advantages

- Up to Cat. 4/PL e in accordance with EN ISO 13849-1, SIL 3 in accordance with EN IEC 62061, SIL 3 in accordance with IEC 61508
- 3 safety functions in one device
- Low housing width of only 22.5mm
- No software configuration required
- Also available with push-in connection

Commercial data

Item number	2903261
Packing unit	1 pc
Note	Made to order (non-returnable)
Sales key	DN01
Product key	DNA191
GTIN	4046356729253
Weight per piece (including packing)	290.5 g
Weight per piece (excluding packing)	26.1 g
Customs tariff number	85371098
Country of origin	DE

Technical data

Product properties

Product type	Safety relays
Application	Emergency stop
	Safety door
	Light grid
	Magnetic switch
Control	1 and 2 channel
Mechanical service life	10x 10 ⁶ cycles
Relay type	Electromechanical relay with force-guided contacts in accordance with IEC/EN 61810-3

Insulation characteristics: Air clearances and creepage distances between the power circuits

Overvoltage category	III
Degree of pollution	2

Electrical properties

Maximum power dissipation for nominal condition	3 W
Nominal operating mode	100% operating factor

Air clearances and creepage distances between the power circuits

Rated insulation voltage	250 V AC
Rated surge voltage/insulation	4 kV/basic isolation (safe isolation, reinforced insulation and 6 kV between input circuit, enabling current paths and safety circuit 1 (13/14, 23/24) and safety circuit 2 (43/44, 53/54).)

Input data

General

Nominal input voltage U_N	24 V DC
Input voltage range in reference to U_N	0.85 ... 1.1
Typical input current at U_N	125 mA (with actuated relays)
	55 mA (Two-channel 24 V/0 V + max. 200 mA control (message outputs 32/62) with non-actuated relays)
Current consumption	typ. 5 mA (I_{max}/I_x inputs)
	20 mA (in electric torque)
Voltage at input/start and feedback circuit	24 V -15 % / +10 % (first channel: 24 V; second channel: 0 V)
Filter time	max. 1.5 ms (Test pulse duration; for all equivalent inputs)
	min. 7.5 ms (Test pulse rate; for all equivalent inputs)
Typical response time	175 ms (monitored/manual start)
	250 ms (automatic start)
Typ. starting time with U_s	250 ms (when controlled via A1)
Typical release time	25 ms (when controlled via S11/S12 and S21/S22)
	20 ms (when controlled via A1)
Concurrence	∞

PSR-SPP-24DC/MXF4/4X1/2X2/B - Safety relays



2903261

<https://www.phoenixcontact.com/us/products/2903261>

Recovery time	1 s (Availability time after activation of sensor circuit: 100ms)
Maximum switching frequency	0.5 Hz
Protective circuit	Surge protection; Suppressor diode
Max. permissible overall conductor resistance	100 Ω
Operating voltage display	1 x LED (green)
Status display	5 x LED (green)

Output data

Contact switching type	4 enabling current paths
	2 semiconductor alarm outputs
Contact material	AgCuNi, +0.2 ... 0.4 μm Au
Maximum switching voltage	250 V AC/DC
Minimum switching voltage	10 V AC/DC
Limiting continuous current	6 A (N/O contact)
	max. 100 mA (Alarm output (24 V DC))
Maximum inrush current	6 A
Inrush current, minimum	10 mA
Sq. Total current	72 A^2 ($I_{TH}^2 = I_1^2 + I_2^2 + I_3^2 + I_4^2$ (note derating))
Interrupting rating (ohmic load) max.	1500 VA (250 V AC, τ = 0 ms)
	66 W (220 V DC, τ = 0 ms)
	66 W (110 V DC, τ = 0 ms)
	100 W (48 V DC, τ = 0 ms)
	144 W (24 V DC, τ = 0 ms)
Maximum interrupting rating (inductive load)	48 W (24 V DC, τ = 40 ms)
	43 W (48 V DC, τ = 40 ms)
Switching power min.	0.1 W
Switching capacity (360/h cycles)	5 A (0,1 Hz; DC13; 24 V)
Switching capacity (3600/h cycles)	3 A (AC15; 230 V)
Output fuse	6 A gL/gG NEOZED (N/O contact)
	4 A gL/gG NEOZED (for low-demand applications)

Connection data

Connection technology

pluggable	yes
-----------	-----

Conductor connection

Connection method	Push-in connection
Conductor cross-section rigid	0.2 mm ² ... 1.5 mm ²
Conductor cross-section flexible	0.2 mm ² ... 1.5 mm ²
Conductor cross-section, flexible, with ferrule, with plastic sleeve	0.25 mm ² ... 1.5 mm ² (only together with CRIMPFOX 6)
Conductor cross-section, flexible, with ferrule, without plastic sleeve	0.25 mm ² ... 1.5 mm ² (only together with CRIMPFOX 6)
Conductor cross-section AWG	24 ... 16
Stripping length	8 mm

PSR-SPP-24DC/MXF4/4X1/2X2/B - Safety relays



2903261

<https://www.phoenixcontact.com/us/products/2903261>

Dimensions

Width	22.5 mm
Height	117.4 mm
Depth	114.5 mm

Material specifications

Color	yellow
-------	--------

Characteristics

Safety data

Stop category (EN 60204-1)	0
----------------------------	---

Safety data: EN ISO 13849

Performance level (PL)	e (5 A DC13; 3 A AC15; 8760 cycles/year)
------------------------	--

Safety data: EN 50156

Safety Integrity Level (SIL)	3
------------------------------	---

Safety data

Safety Integrity Level (SIL)	3
------------------------------	---

Safety data

Safety Integrity Level (SIL)	3
------------------------------	---

Safety data

Safety Integrity Level (SIL)	3
------------------------------	---

Environmental and real-life conditions

Ambient conditions

Degree of protection	IP20
Min. degree of protection of inst. location	IP54
Ambient temperature (operation)	-20 °C ... 45 °C (see derating curve)
Ambient temperature (storage/transport)	-25 °C ... 85 °C
Maximum altitude	≤ 2000 m (Above sea level)
Max. permissible humidity (storage/transport)	75 % (on average, 85% infrequently, non-condensing)
Max. permissible relative humidity (operation)	75 % (on average, 85% infrequently, non-condensing)

Standards and regulations

Air clearances and creepage distances between the power circuits

Standards/regulations	DIN EN 50178/VDE 0160
-----------------------	-----------------------

Mounting

Mounting type	DIN rail mounting
Assembly note	See derating curve
Mounting position	vertical or horizontal

Drawings

Application drawing

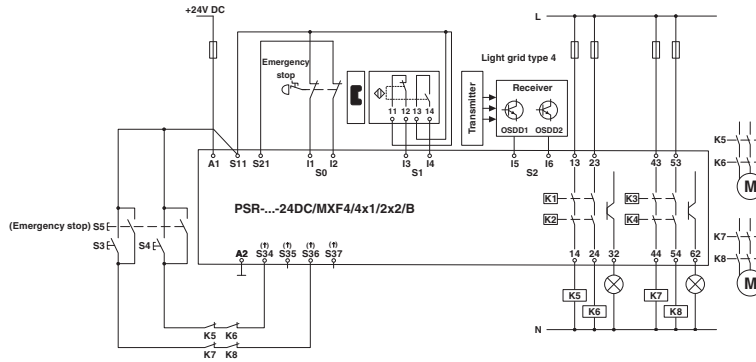

Circuit diagram

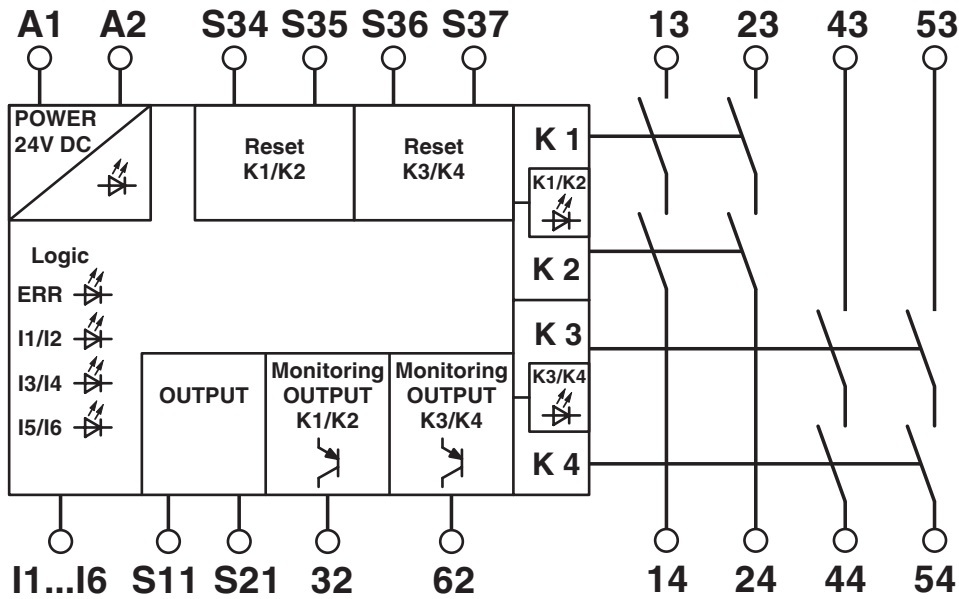

Circuit diagram

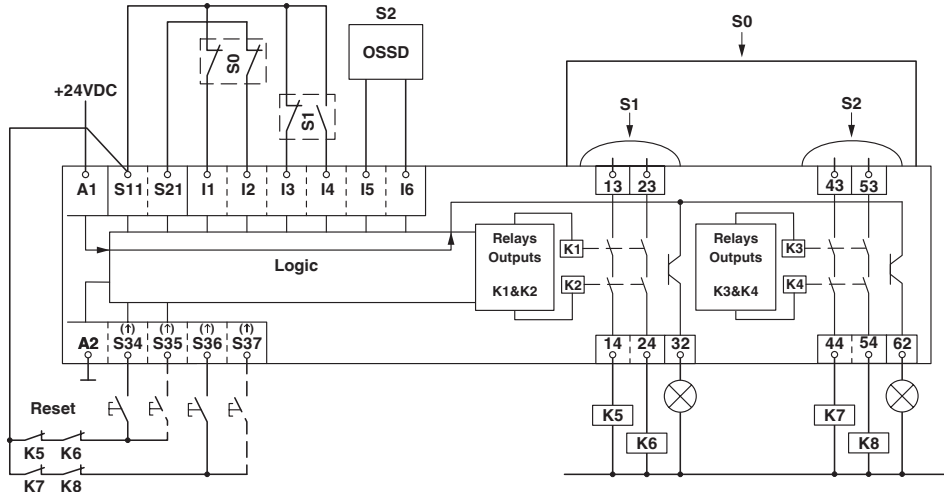

Circuit diagram

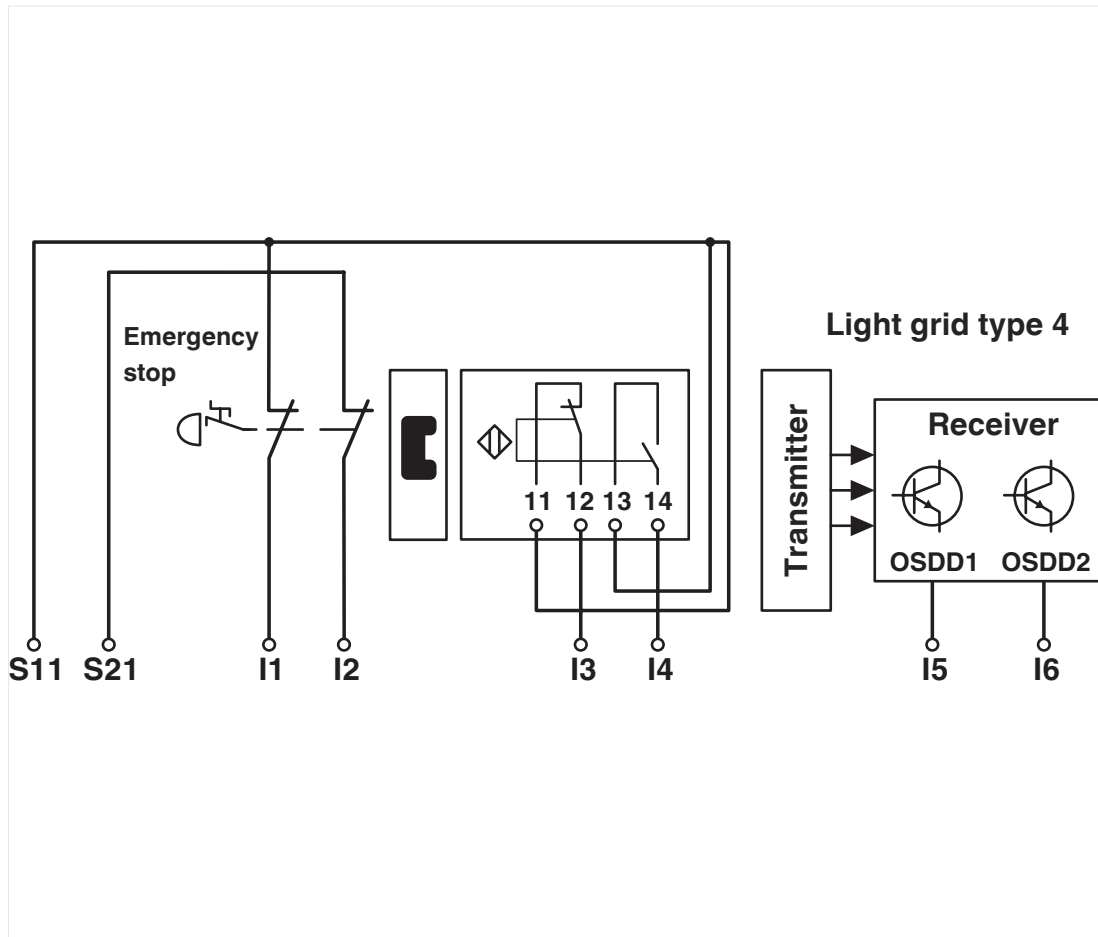

PSR-SPP-24DC/MXF4/4X1/2X2/B - Safety relays



2903261

<https://www.phoenixcontact.com/us/products/2903261>

Classifications

UNSPSC

UNSPSC 21.0	39122205
-------------	----------

2903261

<https://www.phoenixcontact.com/us/products/2903261>

Environmental product compliance

China RoHS

Environment friendly use period (EFUP)	EFUP-50
	An article-related China RoHS declaration table can be found in the download area for the respective article under "Manufacturer declaration". For all articles with EFUP-E, no China RoHS declaration table issued and required.

EU REACH SVHC

REACH candidate substance (CAS No.)	No substance above 0.1 wt%
-------------------------------------	----------------------------

Phoenix Contact 2026 © - all rights reserved
<https://www.phoenixcontact.com>

Phoenix Contact USA
586 Fulling Mill Road
Middletown, PA 17057, United States
(+717) 944-1300
info@phoenixcon.com